

Chapter 1: Introduction to One-shot Learning

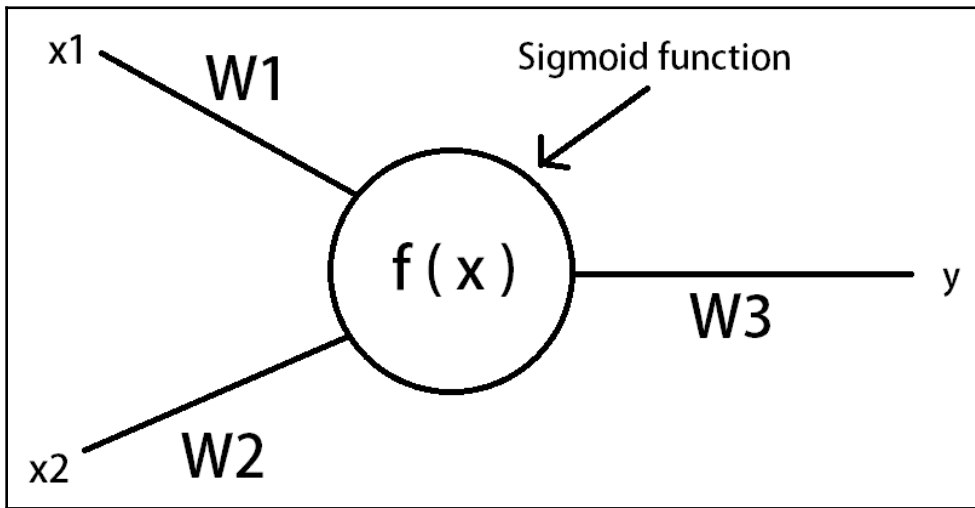

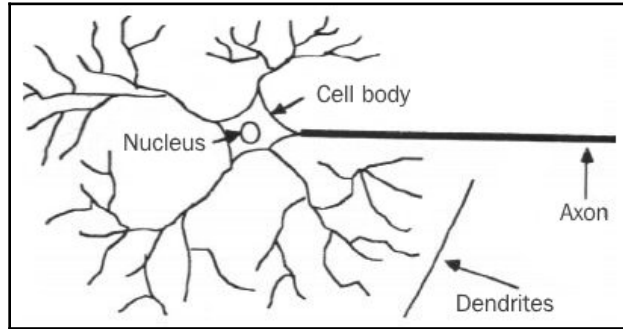

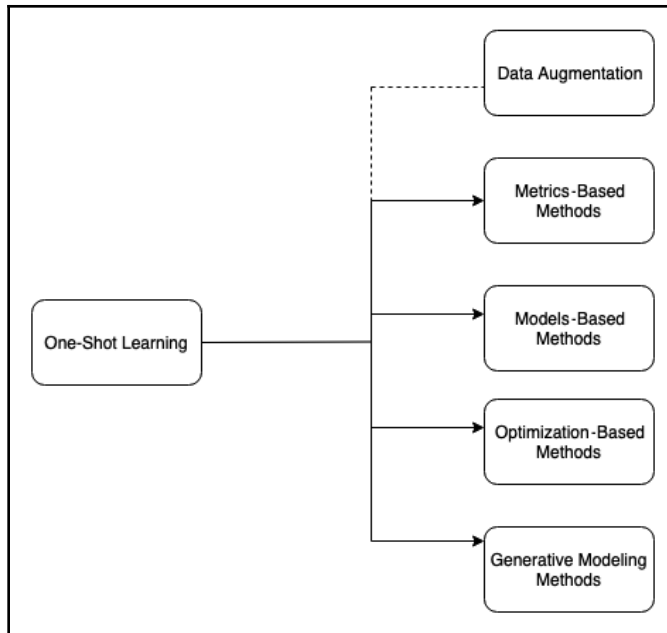

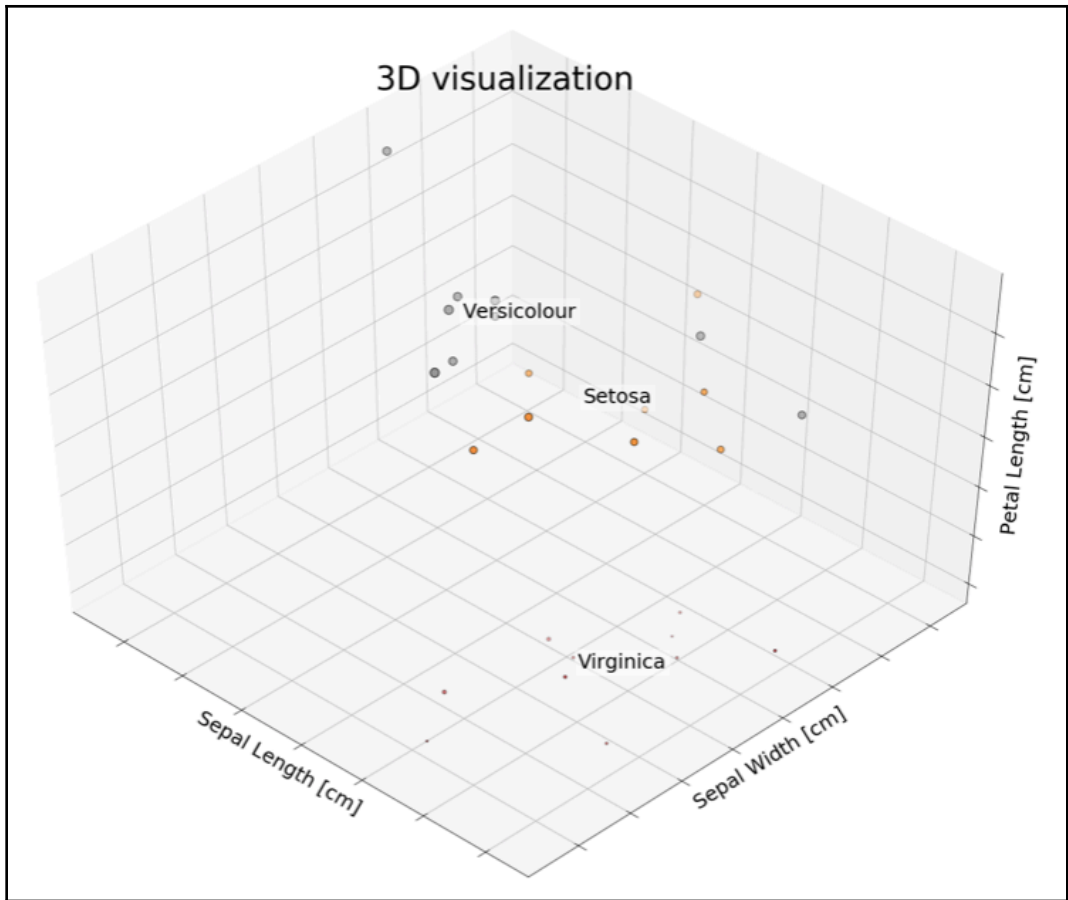

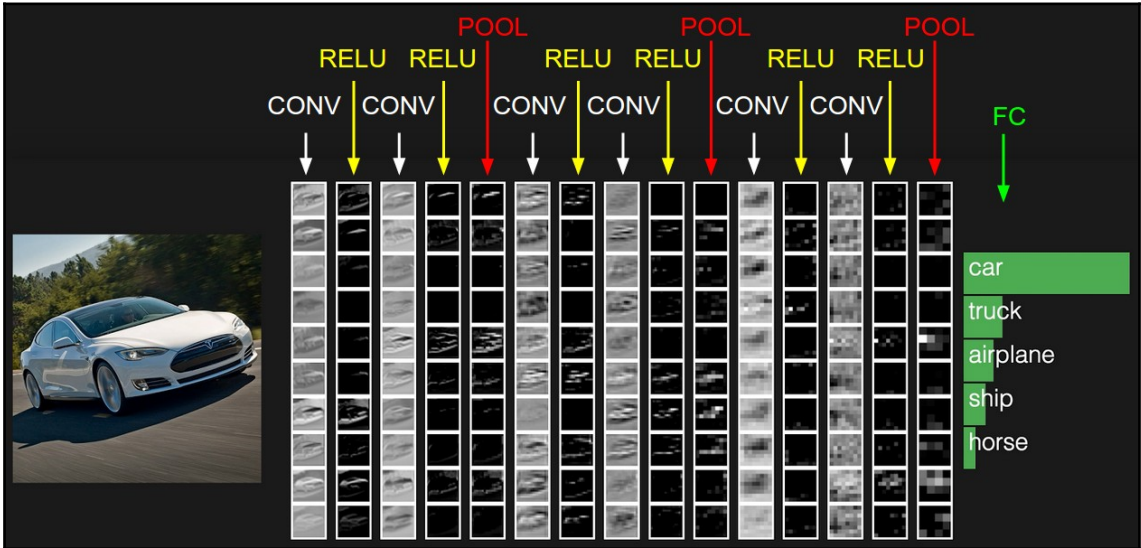





Chapter 2: Metrics-Based Methods



		same	"cow" (speaker #1)	"cow" (speaker #2)	same
		different	"cow" (speaker #1)	"cat" (speaker #2)	different
		same	"can" (speaker #1)	"can" (speaker #2)	same
		different	"can" (speaker #1)	"cab" (speaker #2)	different

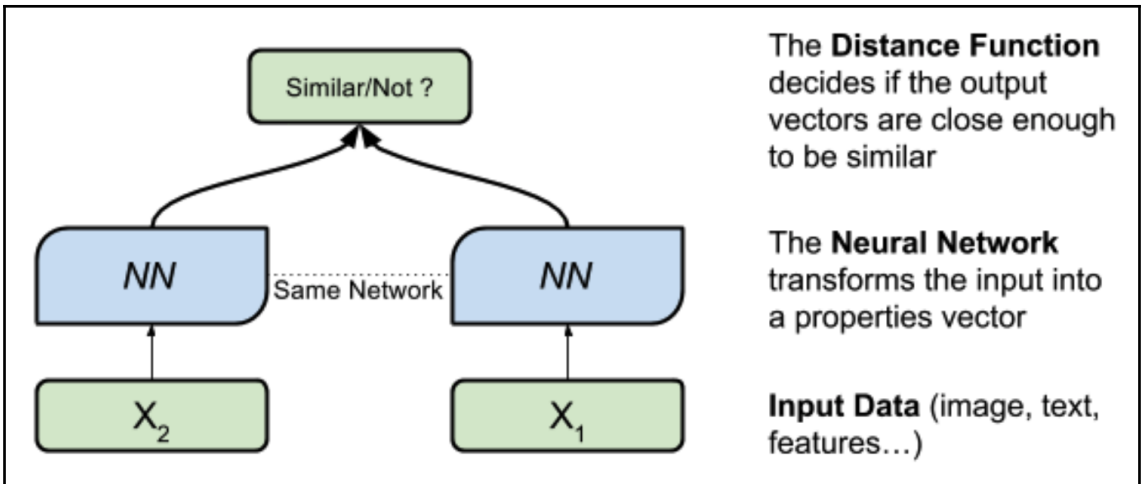

X1	X2	label
		1
		0
		1

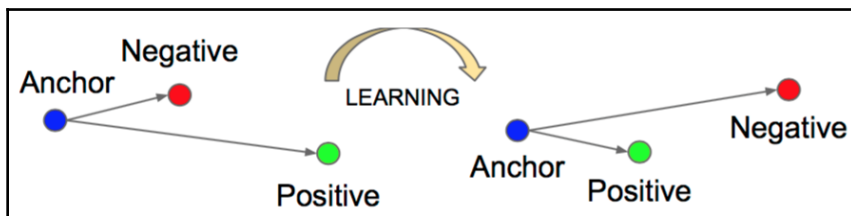

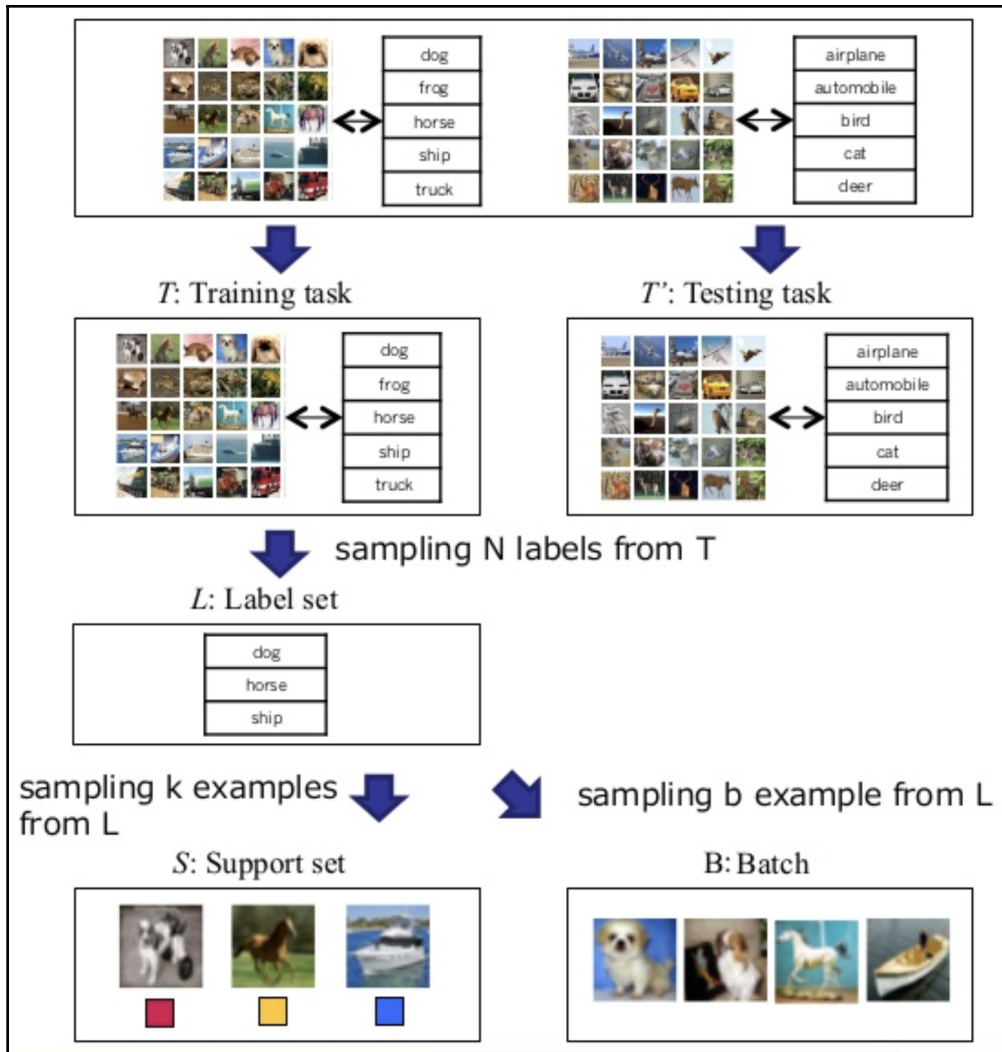

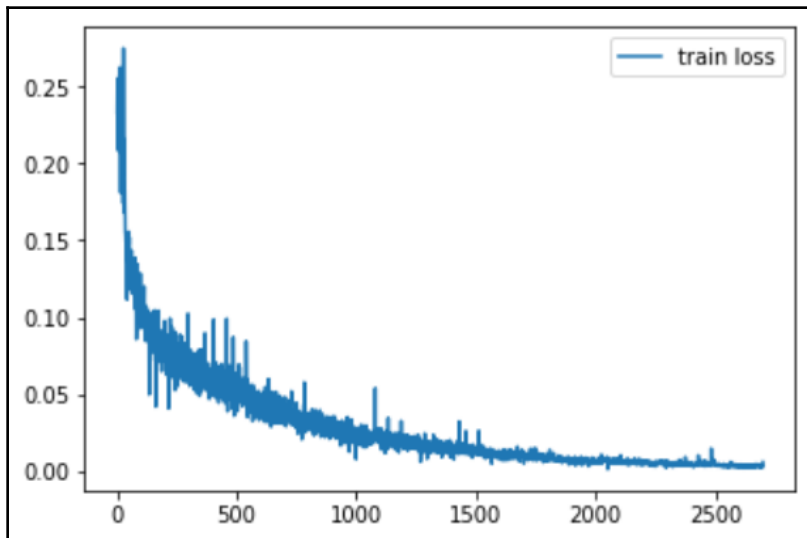
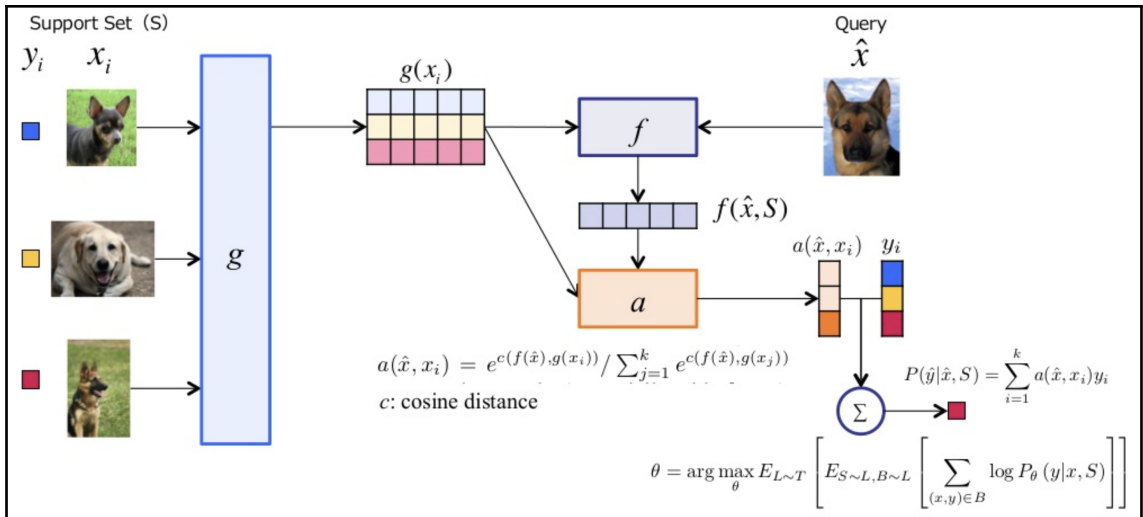

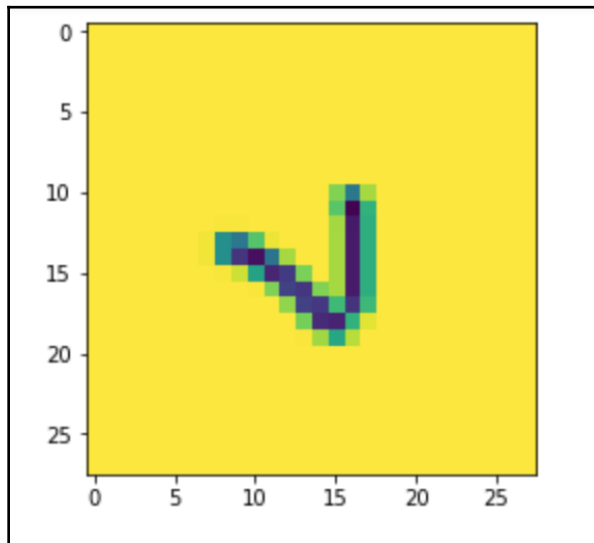
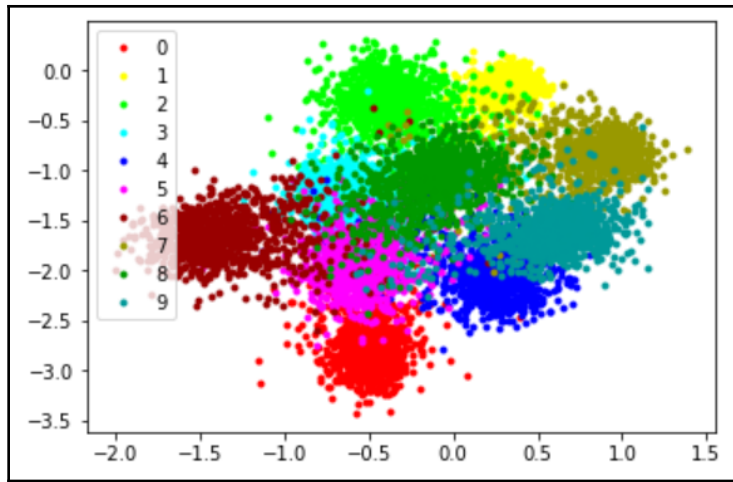

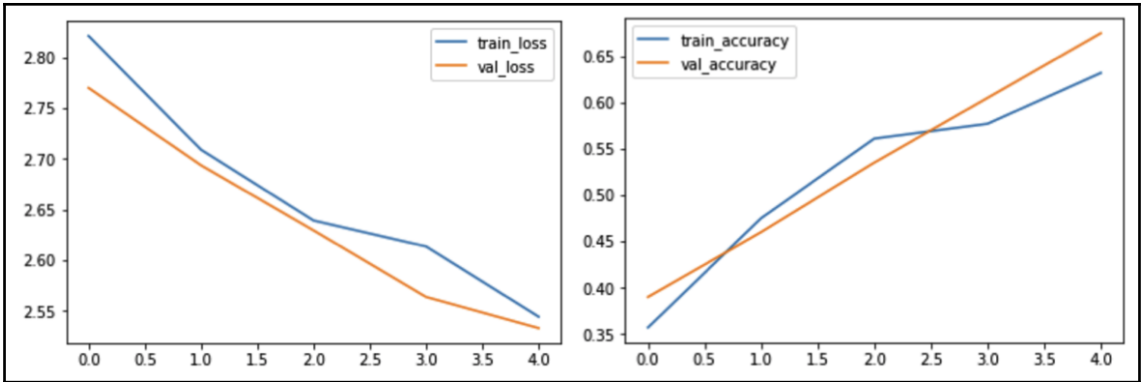

Chapter 3: Model-Based Methods

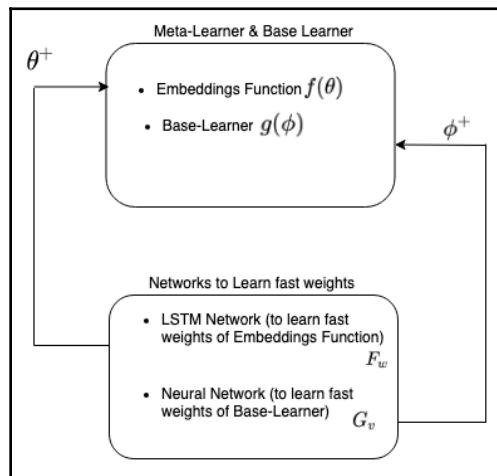
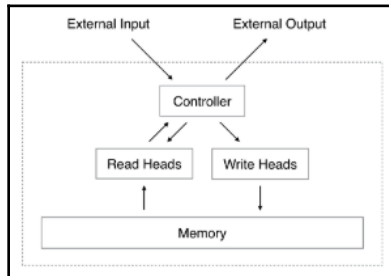

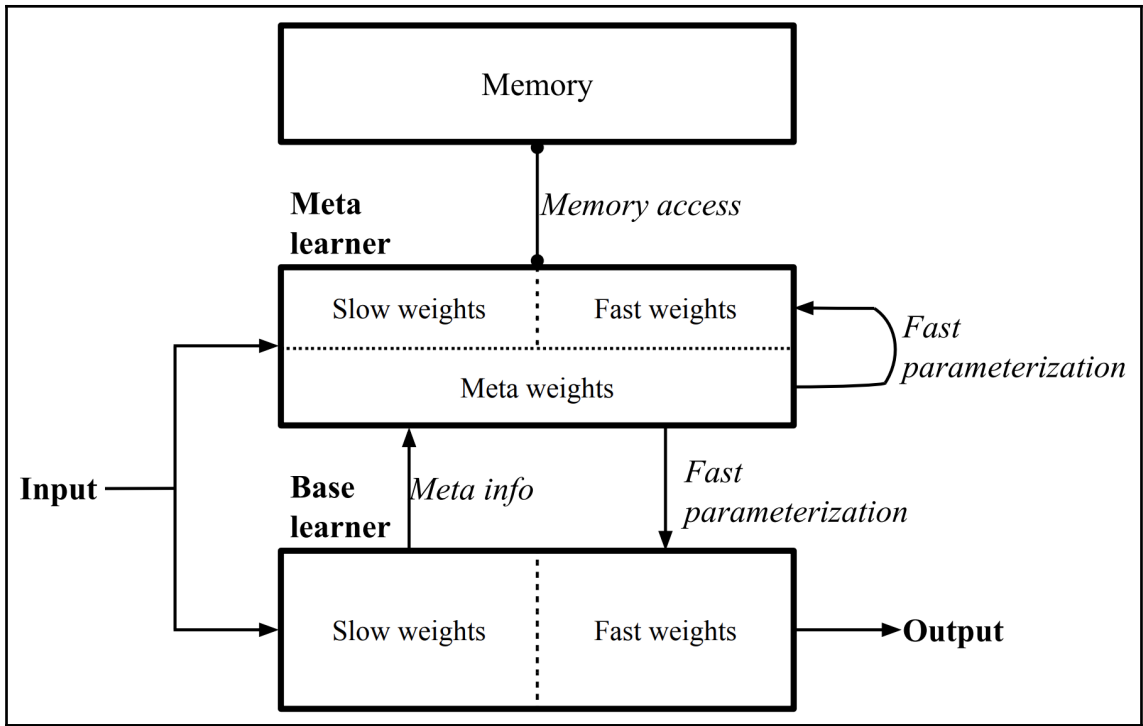

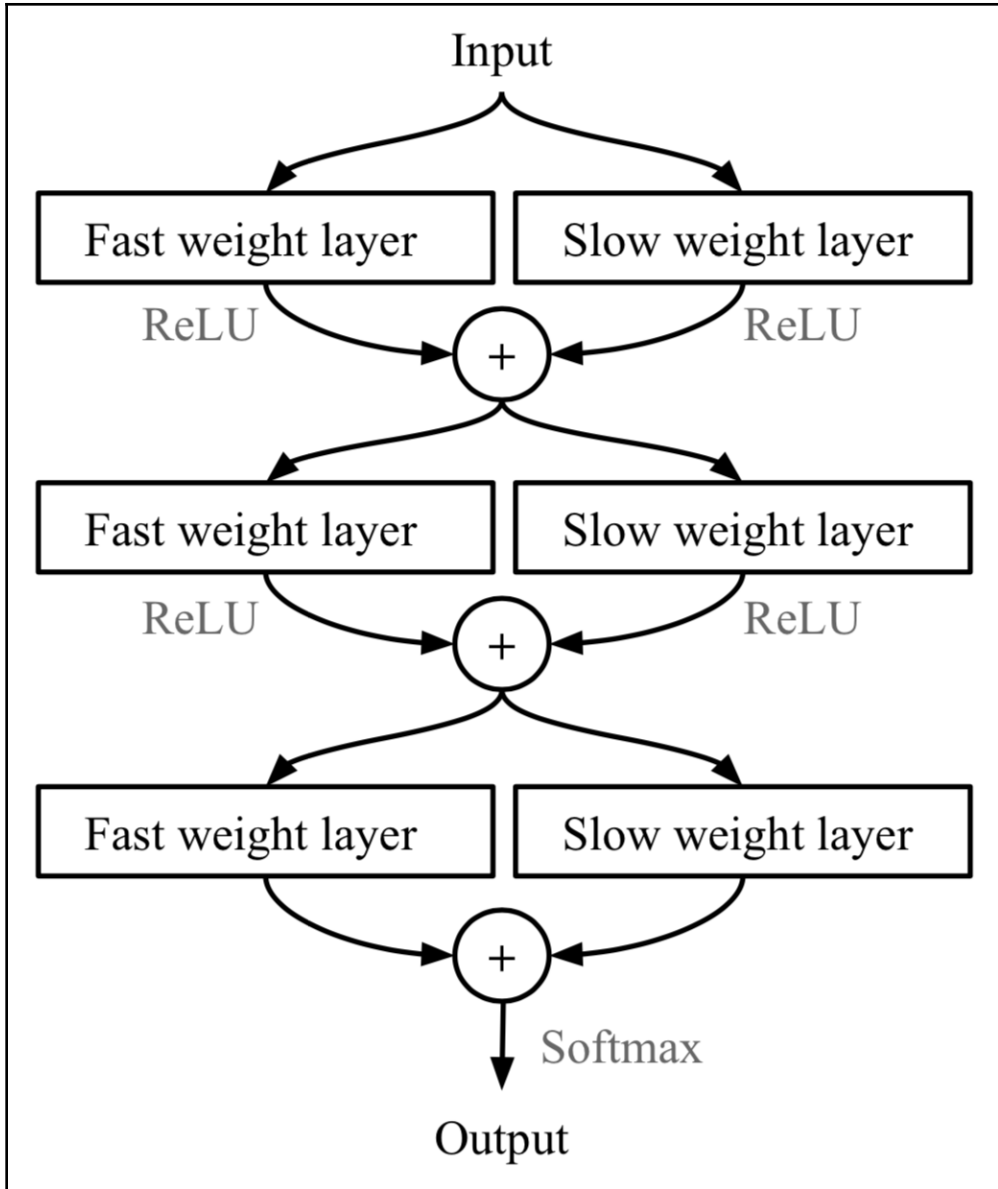

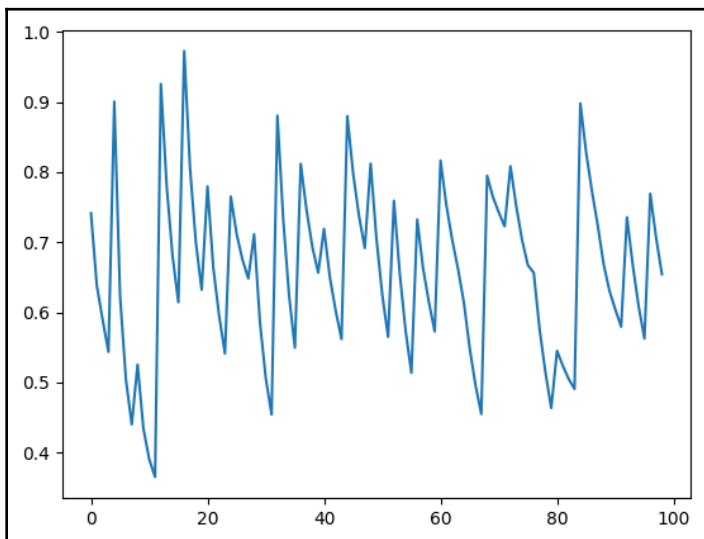
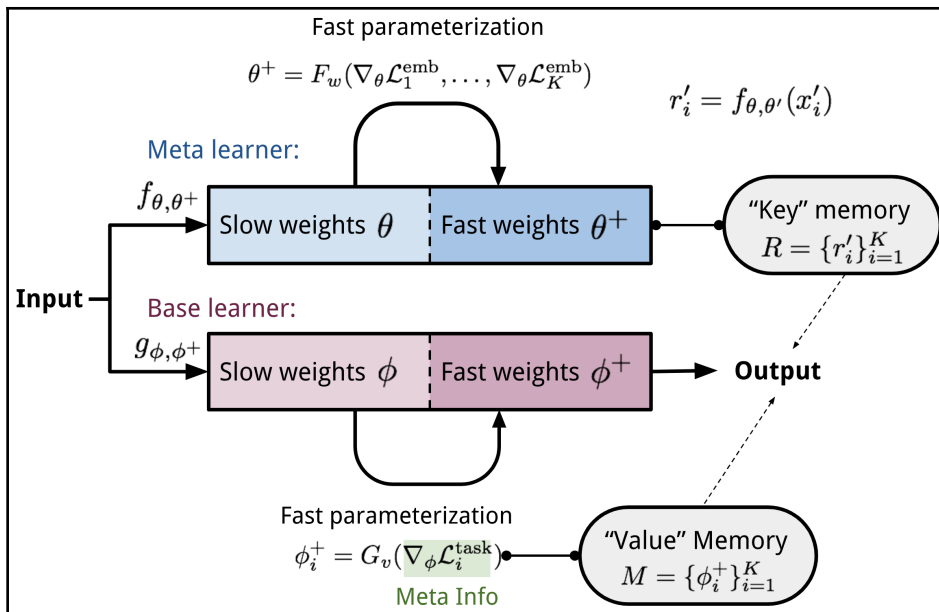

Chapter 4: Optimization-Based Methods

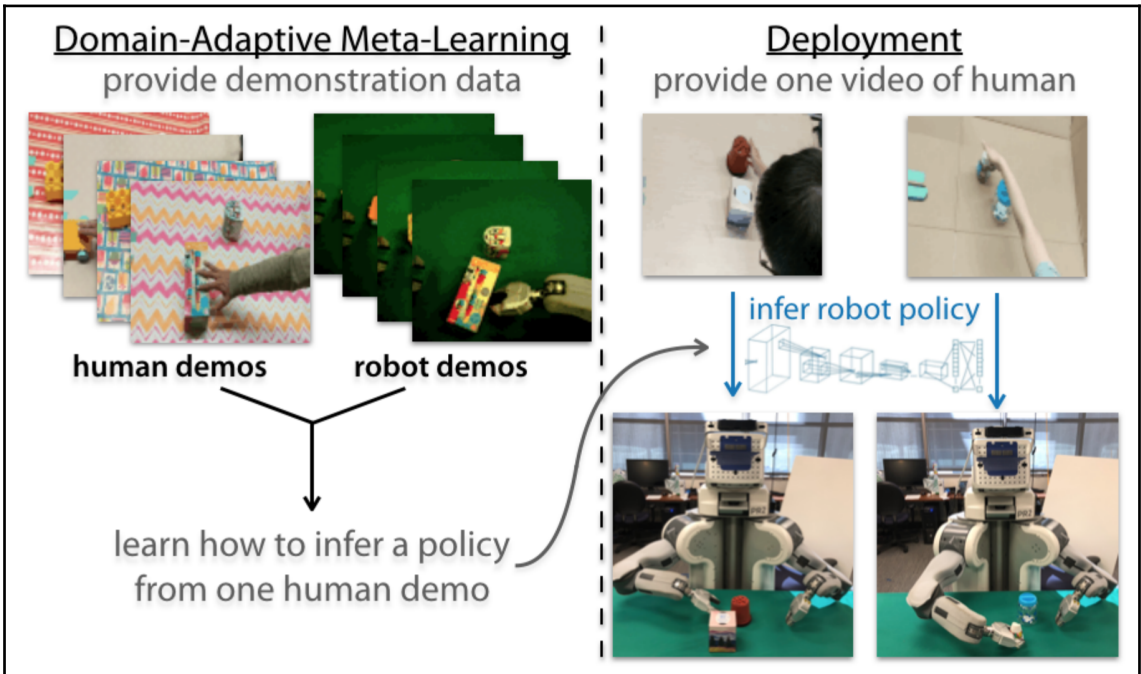
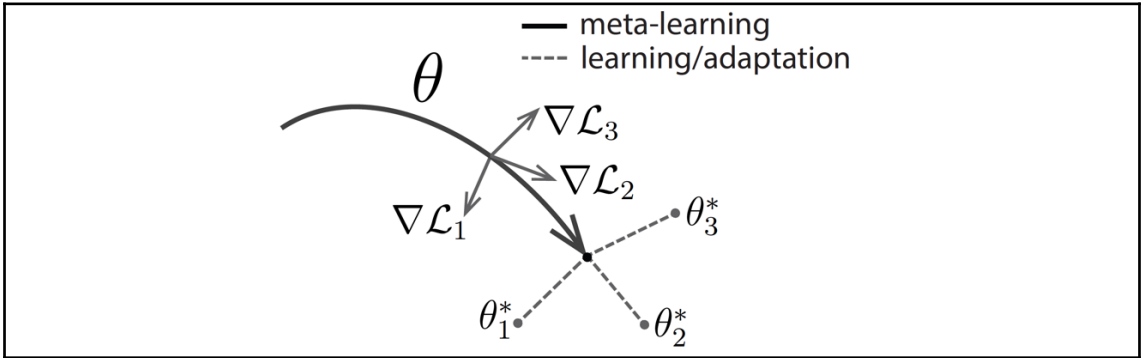

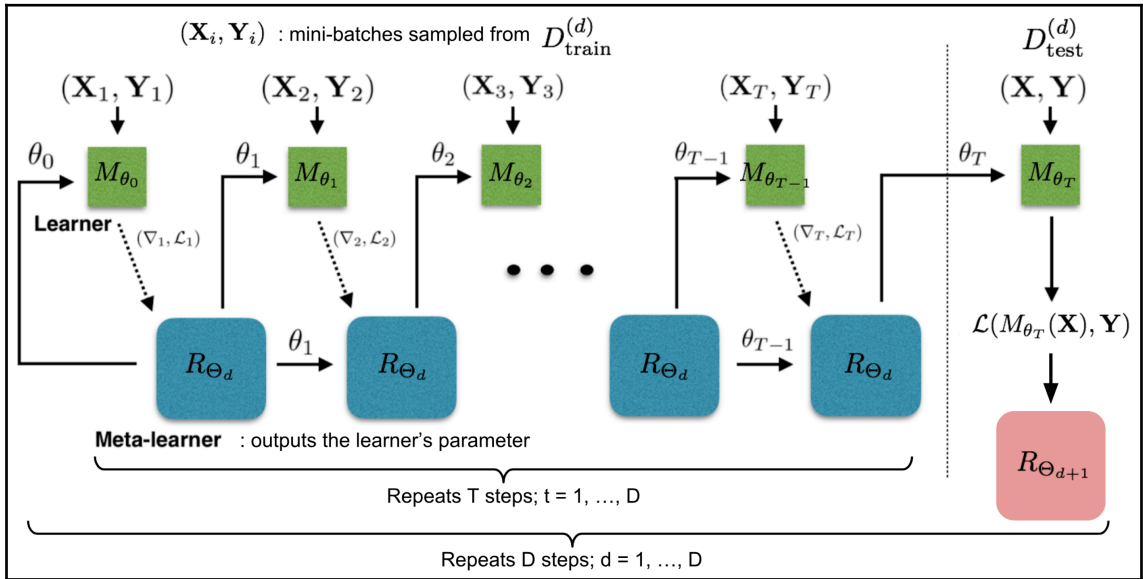
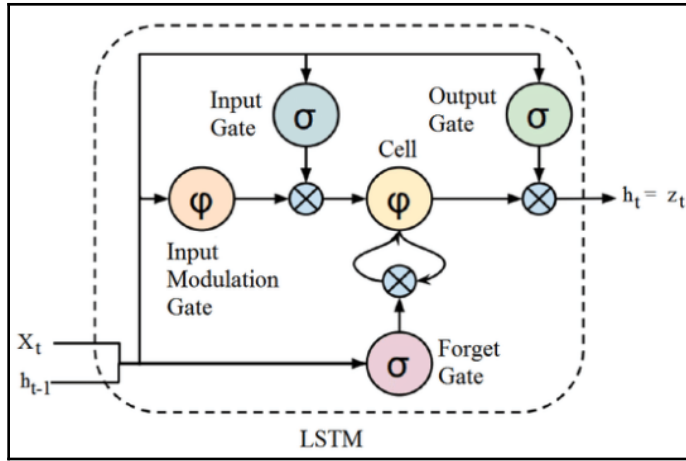

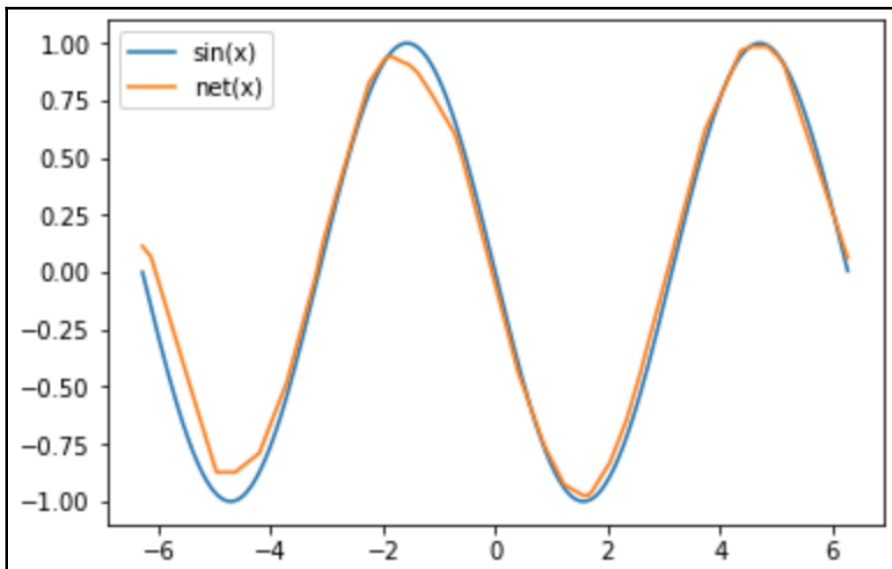
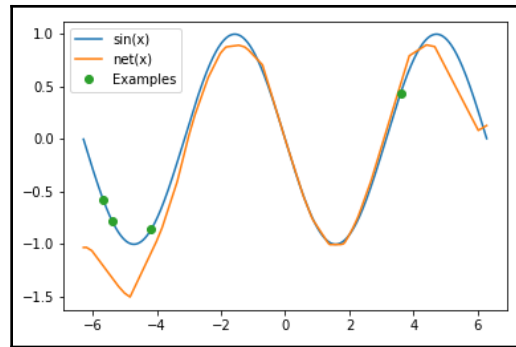

Chapter 5: Generative Modeling-Based Methods

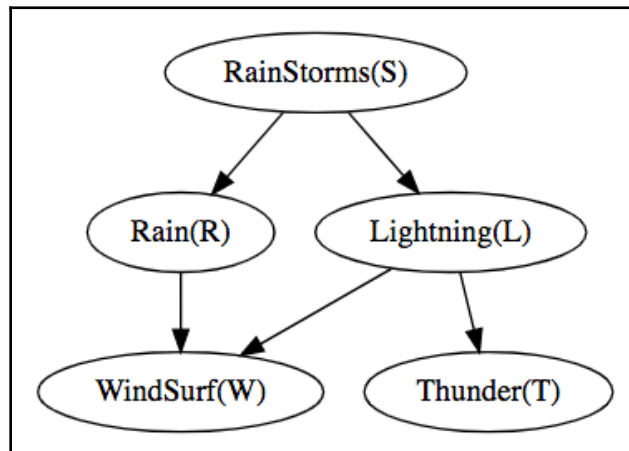
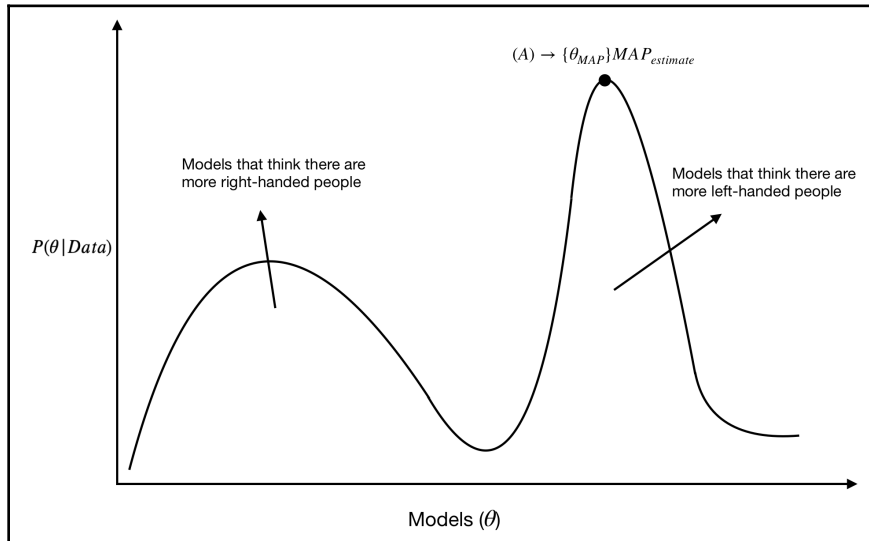

B

i) ಜ

ಲ	ಇ	ಉ	ಎ	ಐ
ಕ	ಖ	ಗ	ಙ	ಝ
ಚ	ಠ	ಡ	ಢ	ವ
ನ	ಯ	ರ	ಹ	ಳ

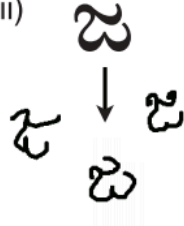
ii) 

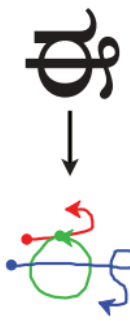
iii) 

iv)

ಯ	ಣ	ದ	ನ	ಲ
ಐ	ಱ	ಖ	ಸ	ಉ

ನ	ನು
ಲ	ಉ

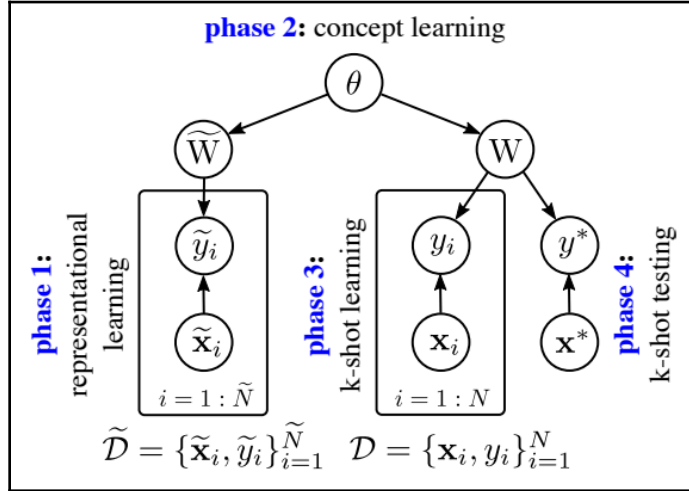
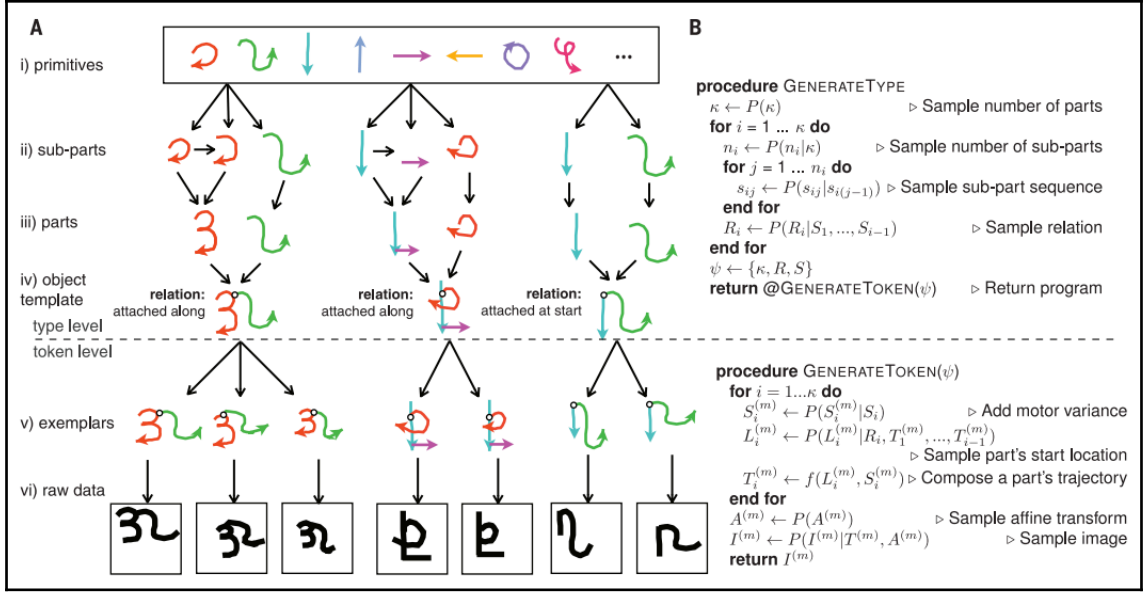

Chapter 6: Conclusions and Other Approaches

