

# Chapter 1: Building a Feedforward Neural Network

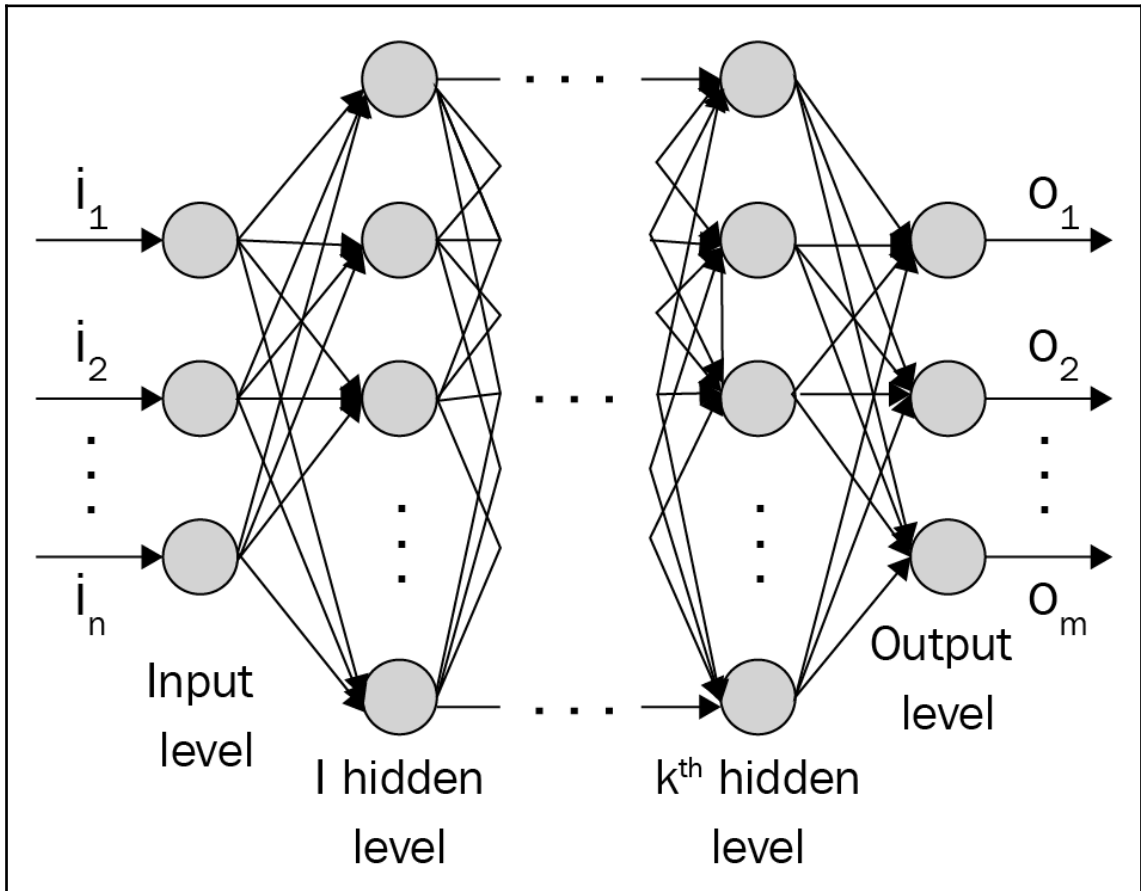

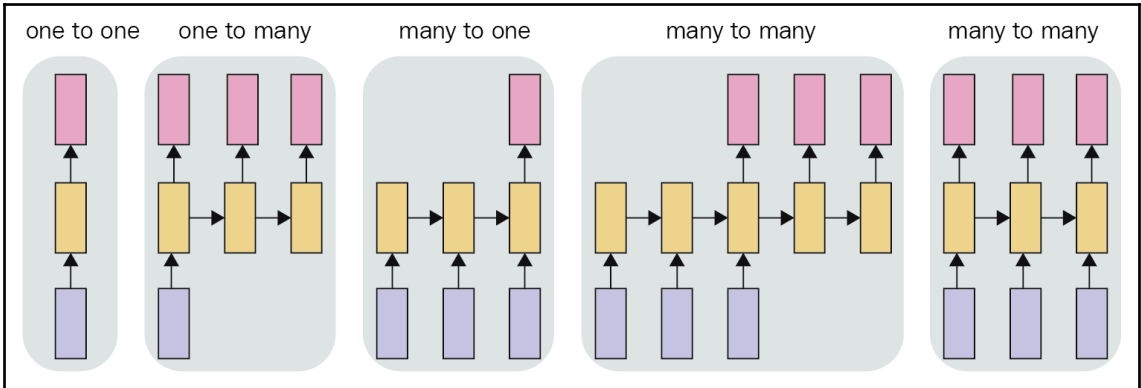

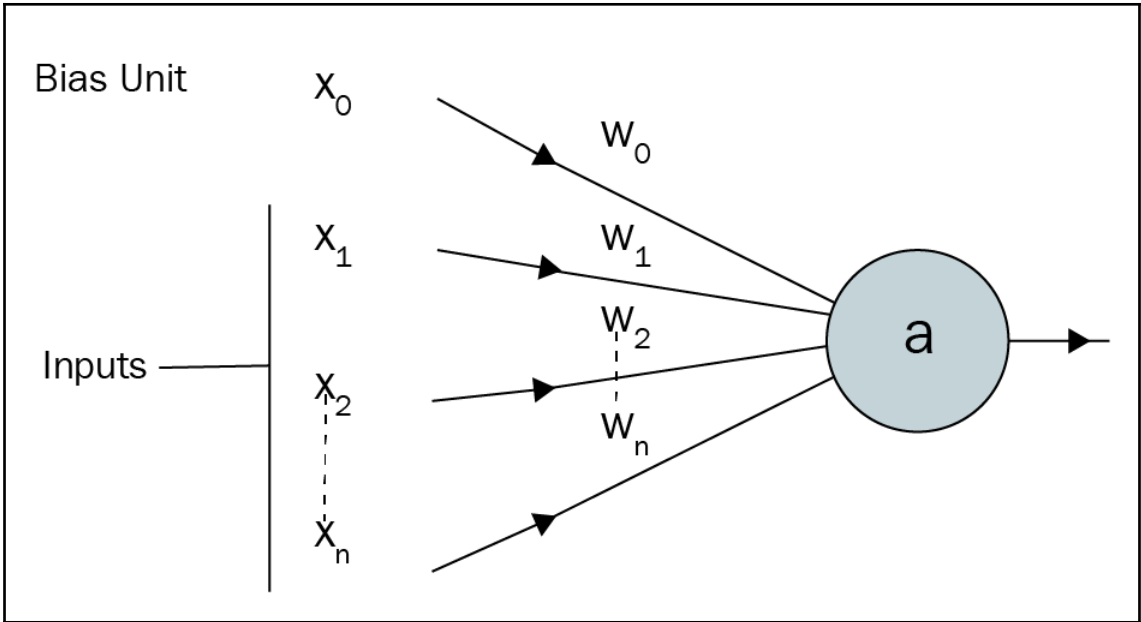

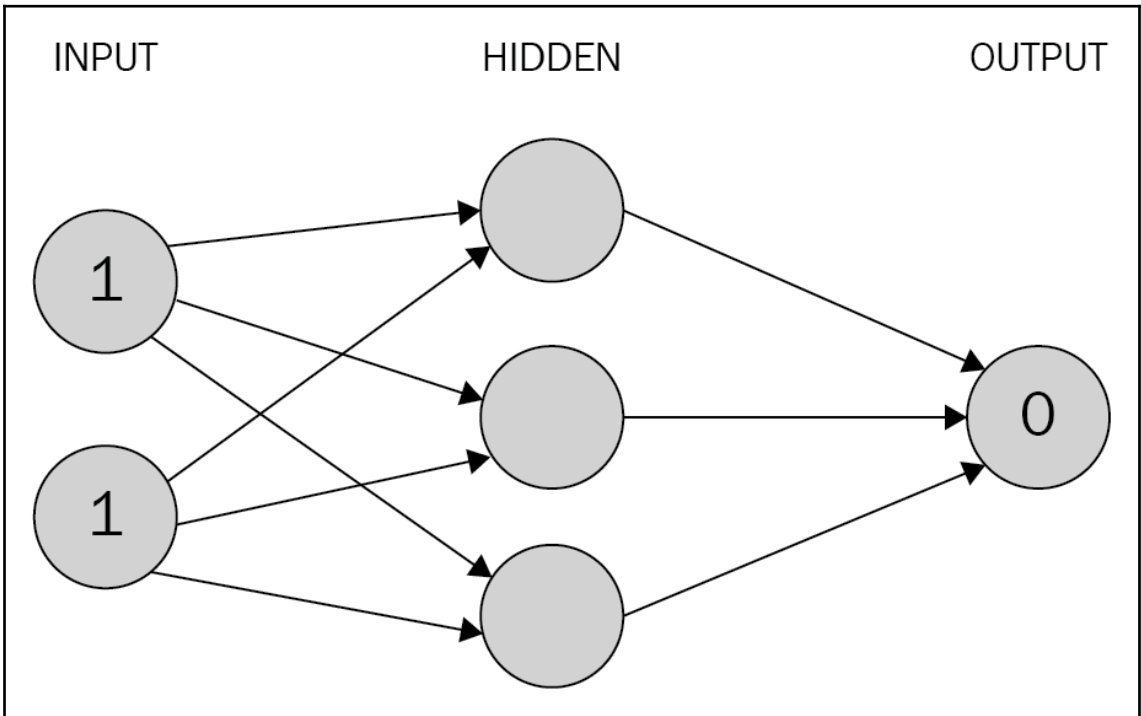
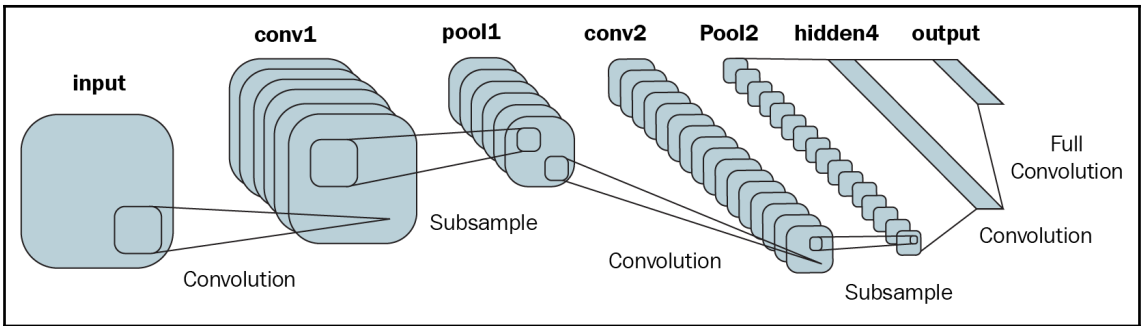
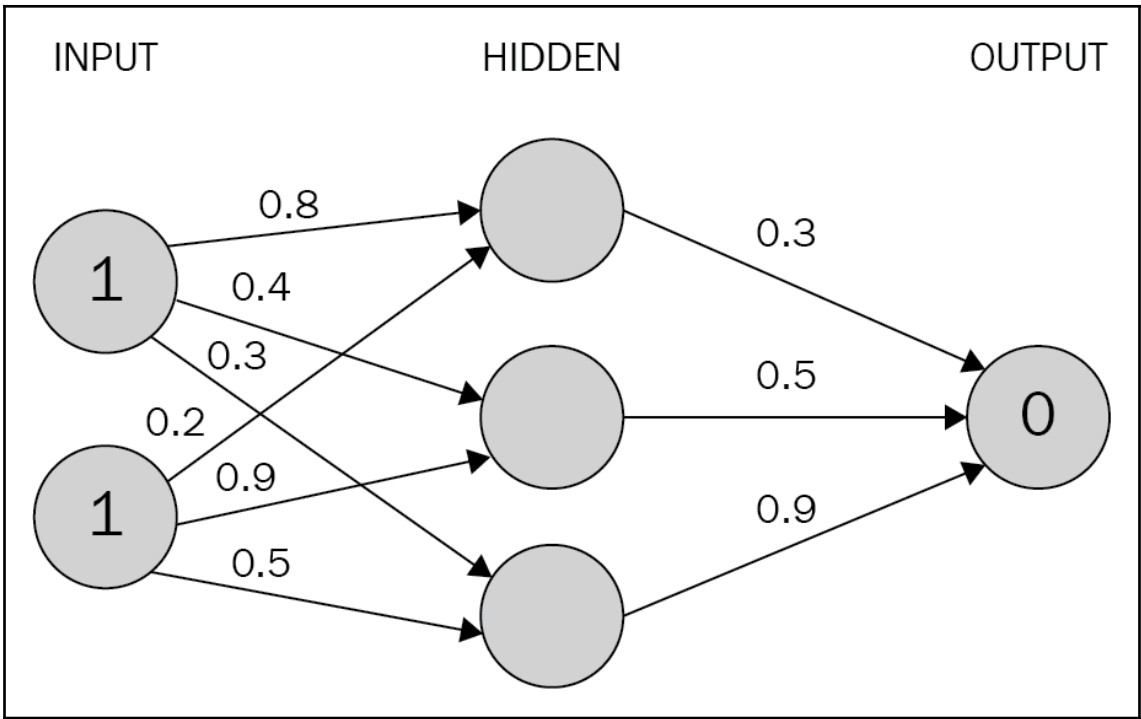



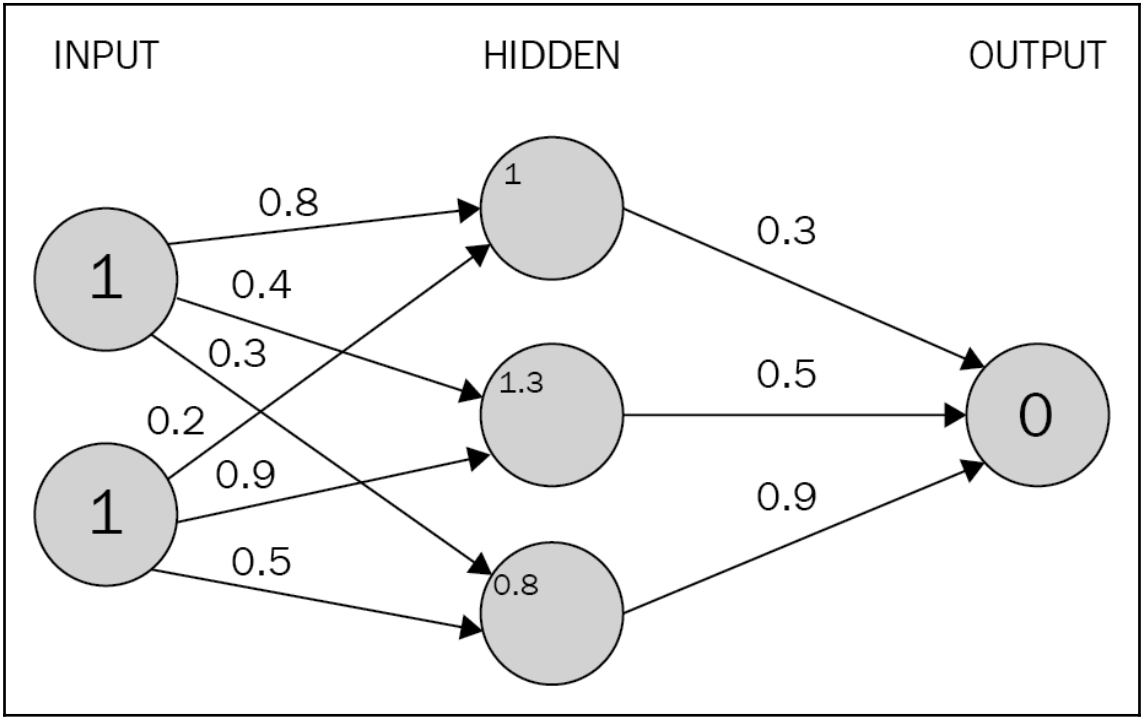











Name	Plot	Equation
Identity		$f(x) = x$
Binary step		$f(x) = \begin{cases} 0 & \text{for } x < 0 \\ 1 & \text{for } x \geq 0 \end{cases}$
Logistic (a.k.a. Soft step)		$f(x) = \frac{1}{1 + e^{-x}}$
TanH		$f(x) = \tanh(x) = \frac{2}{1 + e^{-2x}} - 1$
ArcTan		$f(x) = \tan^{-1}(x)$
Rectified Linear Unit (ReLU)		$f(x) = \begin{cases} 0 & \text{for } x < 0 \\ x & \text{for } x \geq 0 \end{cases}$
Parameteric Rectified Linear Unit (PReLU) [2]		$f(x) = \begin{cases} \alpha x & \text{for } x < 0 \\ x & \text{for } x \geq 0 \end{cases}$
Exponential Linear Unit (ELU) [3]		$f(x) = \begin{cases} \alpha(e^x - 1) & \text{for } x < 0 \\ x & \text{for } x \geq 0 \end{cases}$
SoftPlus		$f(x) = \log_e(1 + e^x)$

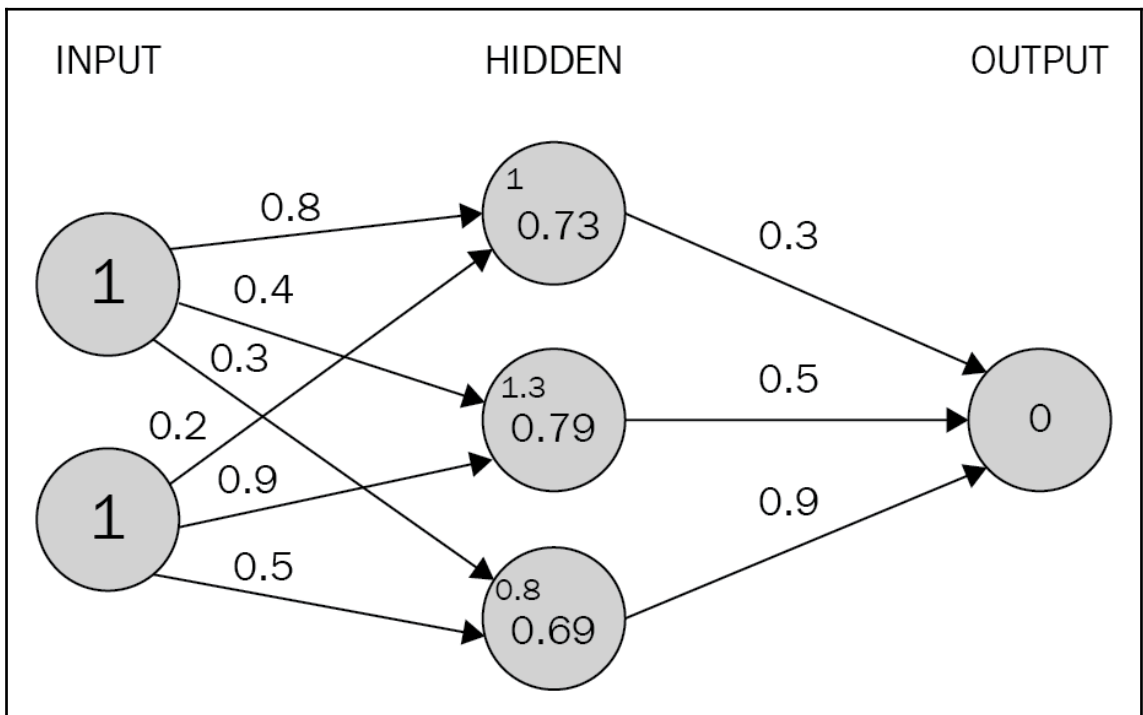
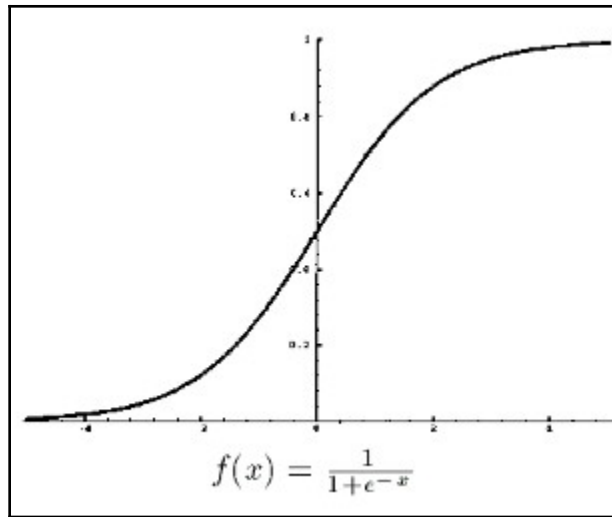

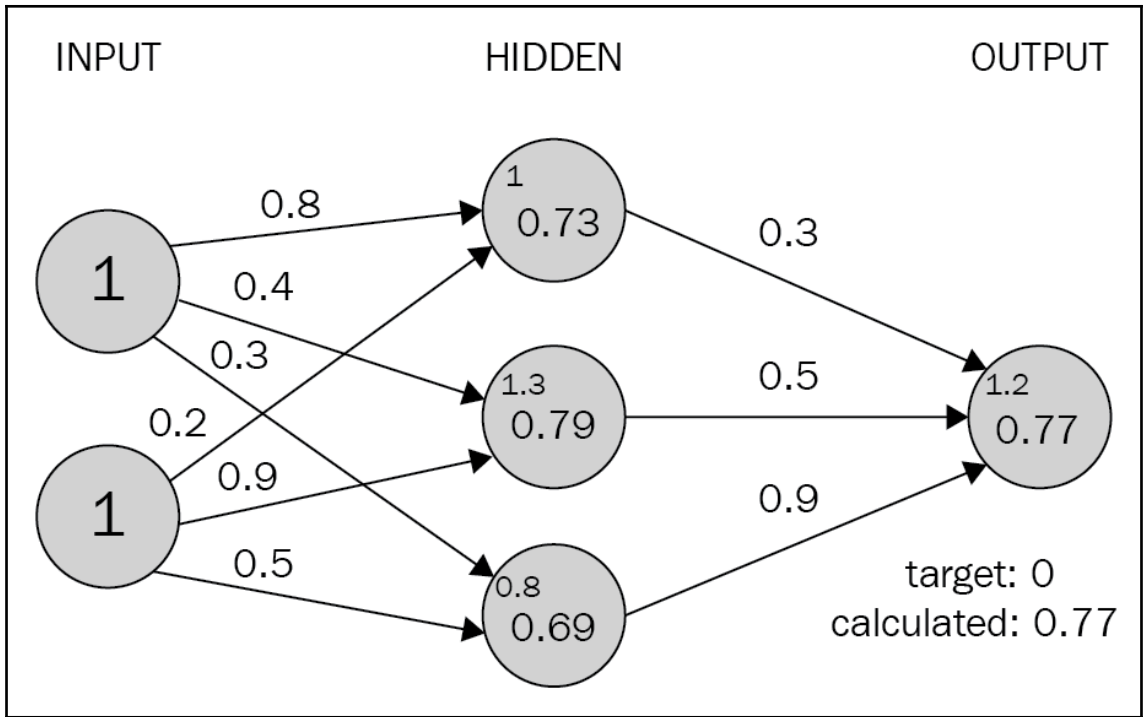

```
[array([[ -1.0281681 ,  0.11109705, -0.08701682]], dtype=float32),
array([ 0.          , -0.10836656,  0.          ], dtype=float32),
array([[ 0.5071335 ],
       [-0.74833566],
       [ 0.10594594]], dtype=float32),
array([0.11973583], dtype=float32)]
```

Layer (type)	Output Shape	Param #
dense_1 (Dense)	(None, 3)	6
dense_2 (Dense)	(None, 1)	4
Total params: 10		
Trainable params: 10		
Non-trainable params: 0		

---

```
[<tf.Variable 'dense_1/kernel:0' shape=(1, 3) dtype=float32_ref>,
<tf.Variable 'dense_1/bias:0' shape=(3,) dtype=float32_ref>,
<tf.Variable 'dense_2/kernel:0' shape=(3, 1) dtype=float32_ref>,
<tf.Variable 'dense_2/bias:0' shape=(1,) dtype=float32_ref>]
```

```
[array([[ -1.0281681 ,  0.11109705, -0.08701682]], dtype=float32),
array([ 0.          , -0.10836656,  0.          ], dtype=float32),
array([[ 0.5071335 ],
       [-0.74833566],
       [ 0.10594594]], dtype=float32),
array([0.11973583], dtype=float32)]
```

```
array([[0.09999999],
       [0.09999999]], dtype=float32)
```

```
array([[ 9.865341],
       [11.799512]], dtype=float32)
```

---

## Chapter 2: Building a Deep Feedforward Neural Network

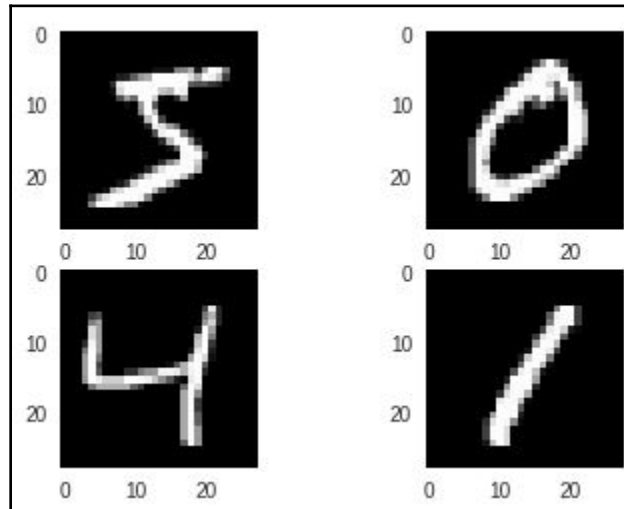

Layer (type)	Output Shape	Param #
dense_1 (Dense)	(None, 1000)	785000
dense_2 (Dense)	(None, 10)	10010
-----		
Total params: 795,010		
Trainable params: 795,010		
Non-trainable params: 0		

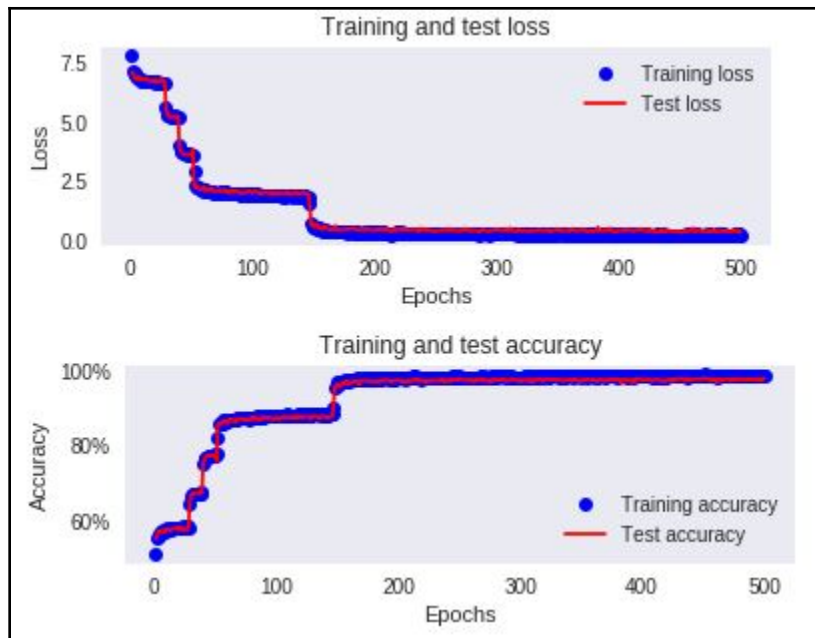

Scenario	Input	Weight	bias	Sigmoid
1	255	0.01	0	0.93
2	255	0.1	0	1.00
3	255	0.2	0	1.00
4	255	0.3	0	1.00
5	255	0.4	0	1.00
6	255	0.5	0	1.00
7	255	0.6	0	1.00
8	255	0.7	0	1.00
9	255	0.8	0	1.00
10	255	0.9	0	1.00

Scenario	Input	Weight	bias	Sigmoid	
1	1	1	0.01	0	0.50
2	1	1	0.1	0	0.52
3	1	1	0.2	0	0.55
4	1	1	0.3	0	0.57
5	1	1	0.4	0	0.60
6	1	1	0.5	0	0.62
7	1	1	0.6	0	0.65
8	1	1	0.7	0	0.67
9	1	1	0.8	0	0.69
10	1	1	0.9	0	0.71

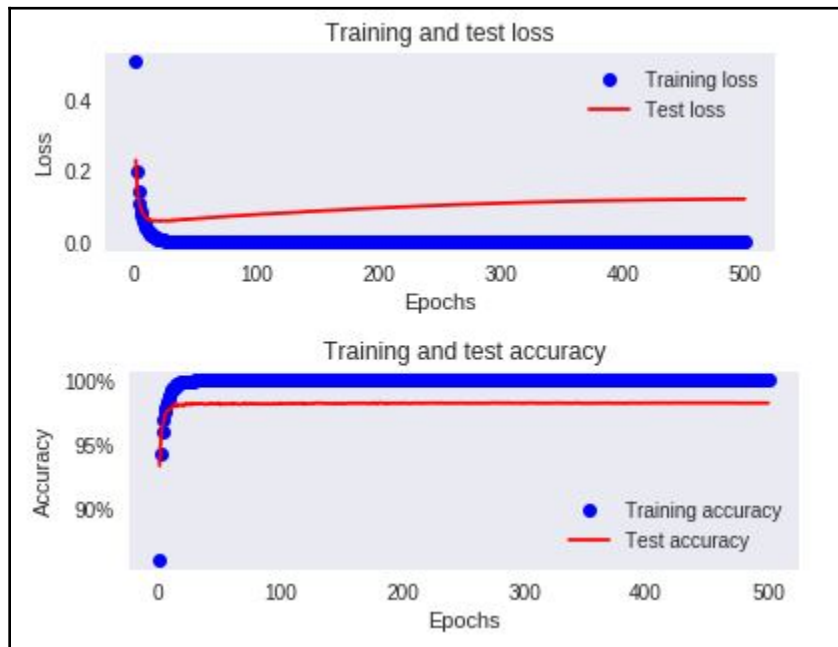



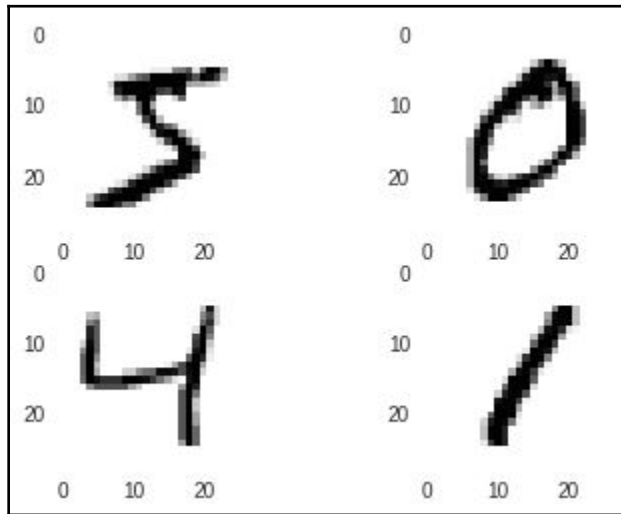
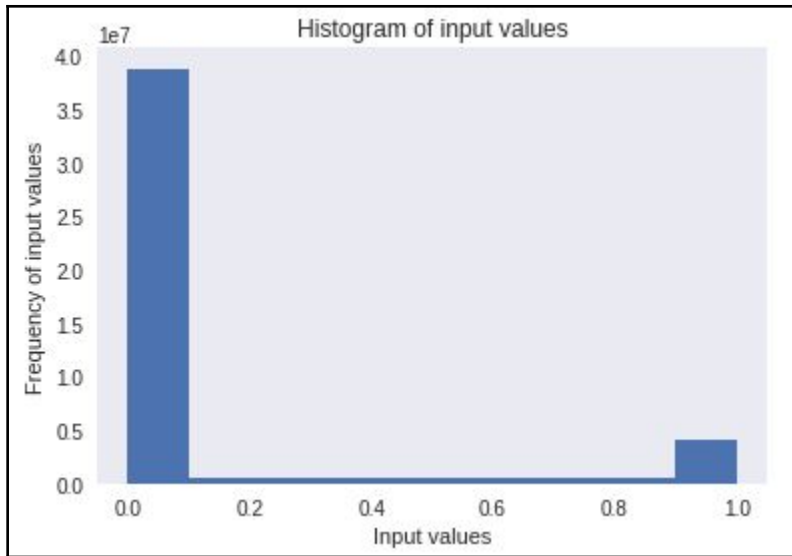

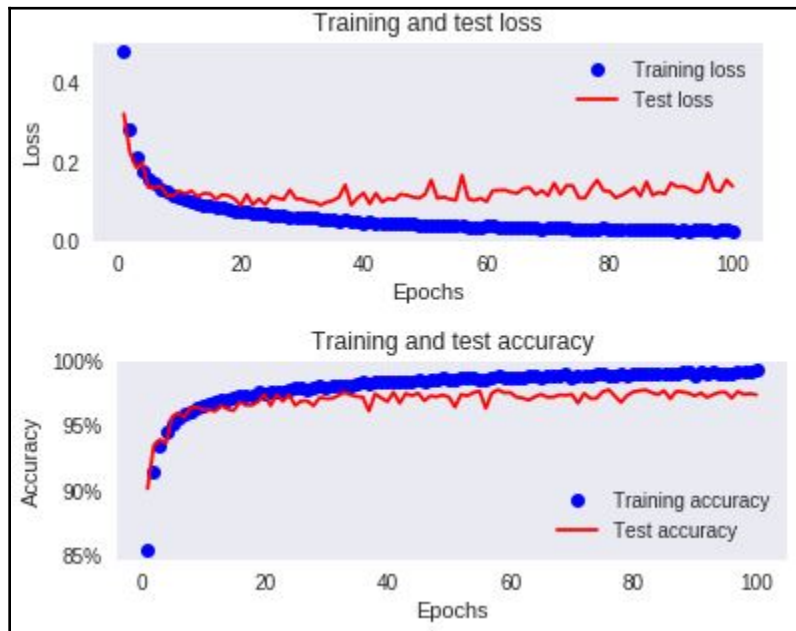
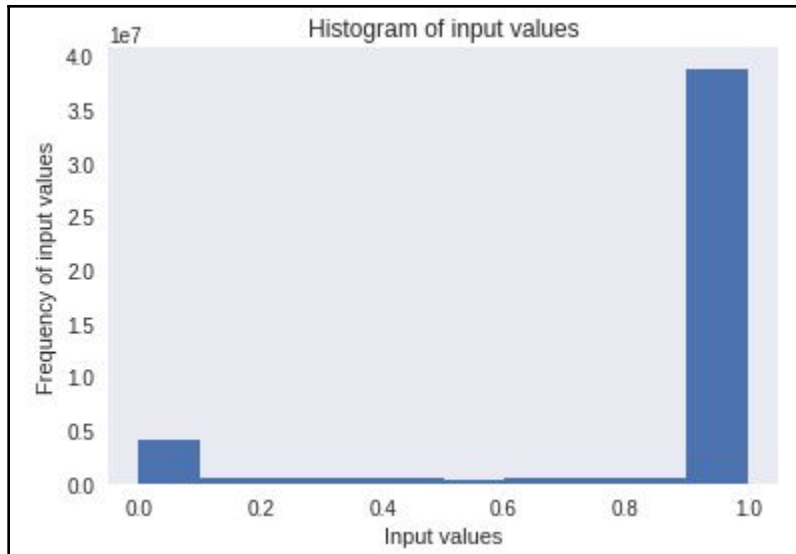

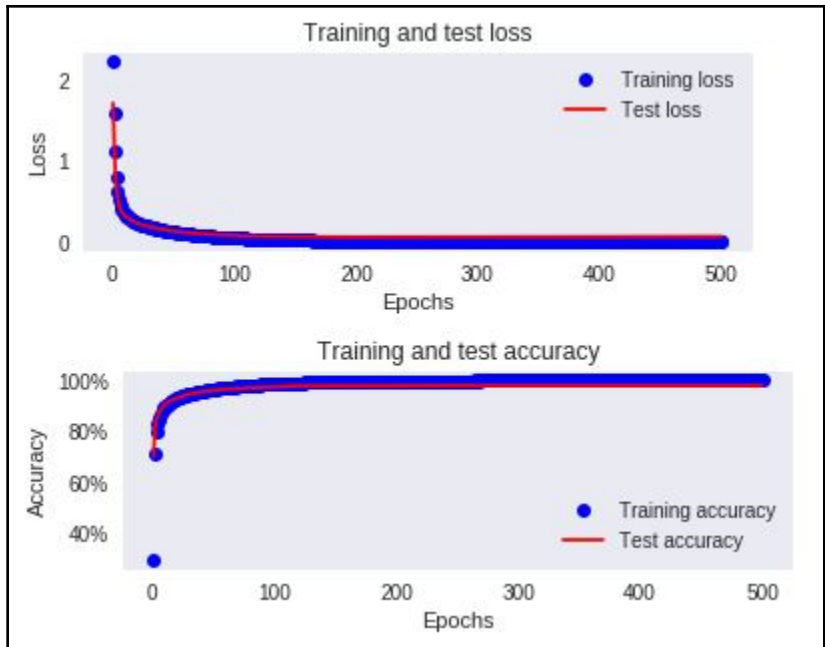

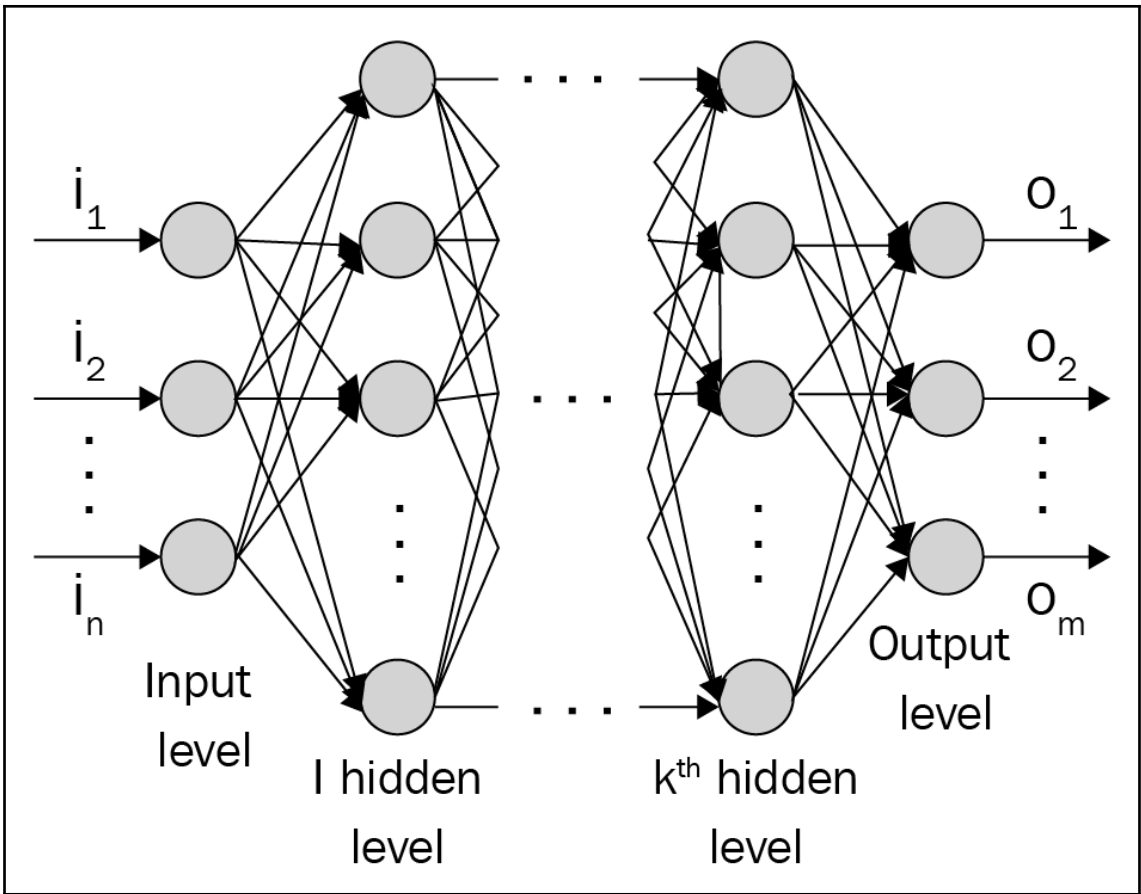

Layer (type)	Output Shape	Param #
dense_3 (Dense)	(None, 1000)	785000
dense_4 (Dense)	(None, 1000)	1001000
dense_5 (Dense)	(None, 1000)	1001000
dense_6 (Dense)	(None, 10)	10010
Total params: 2,797,010		
Trainable params: 2,797,010		
Non-trainable params: 0		

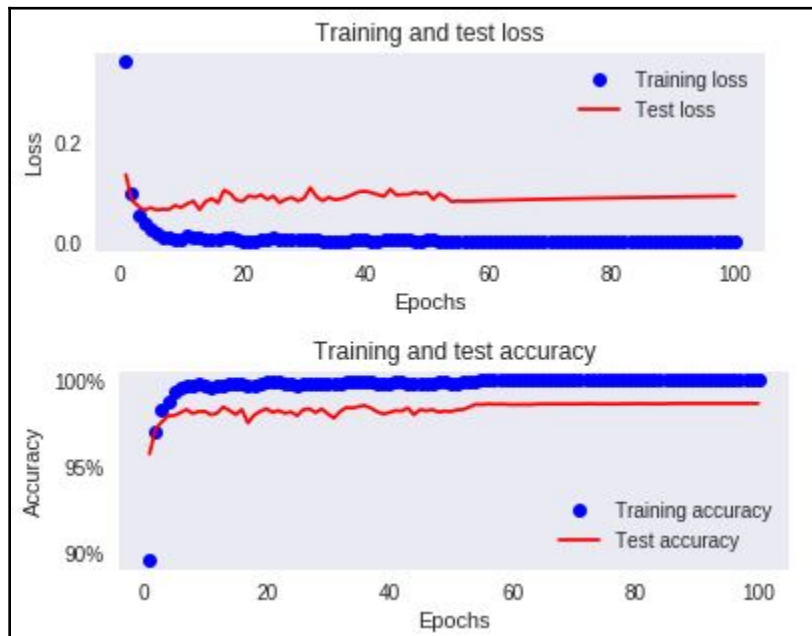

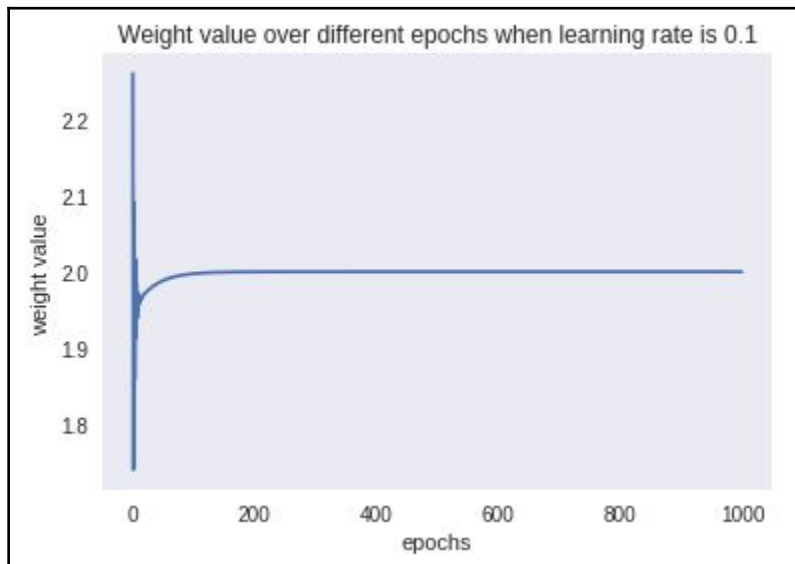
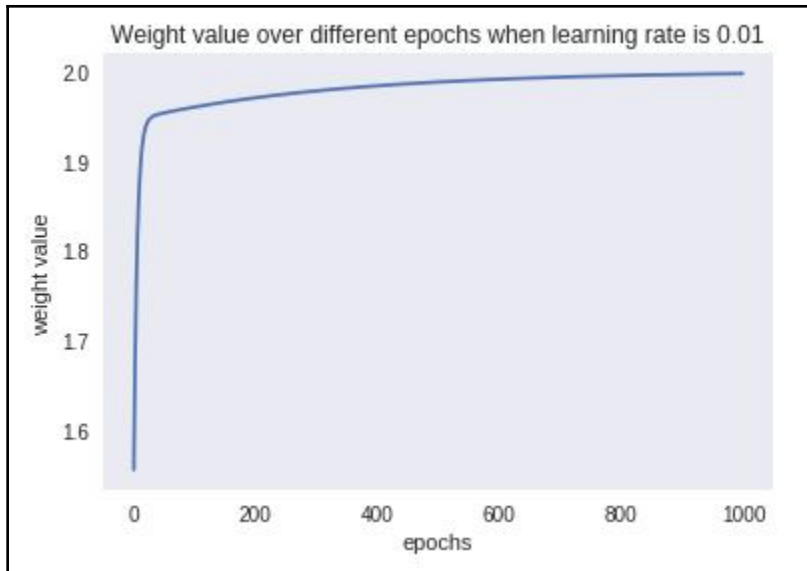

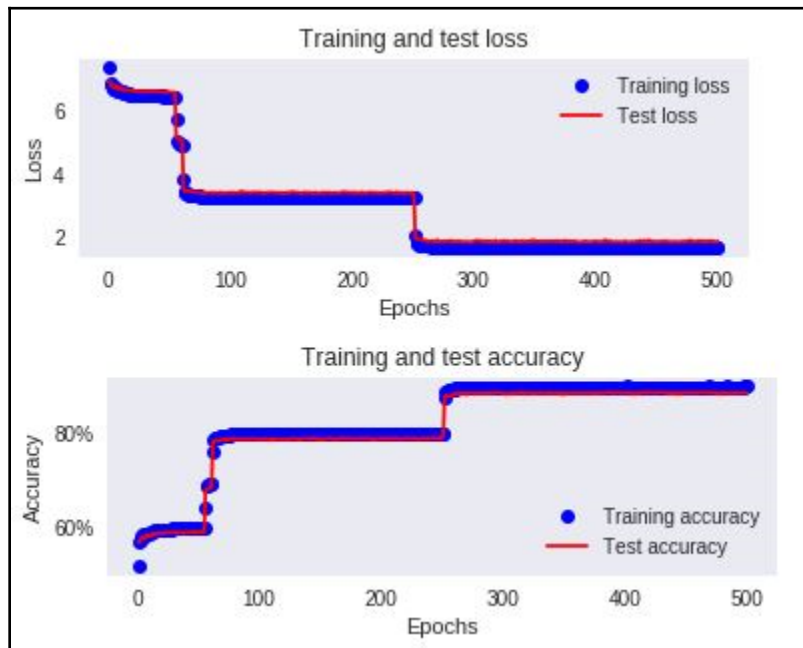
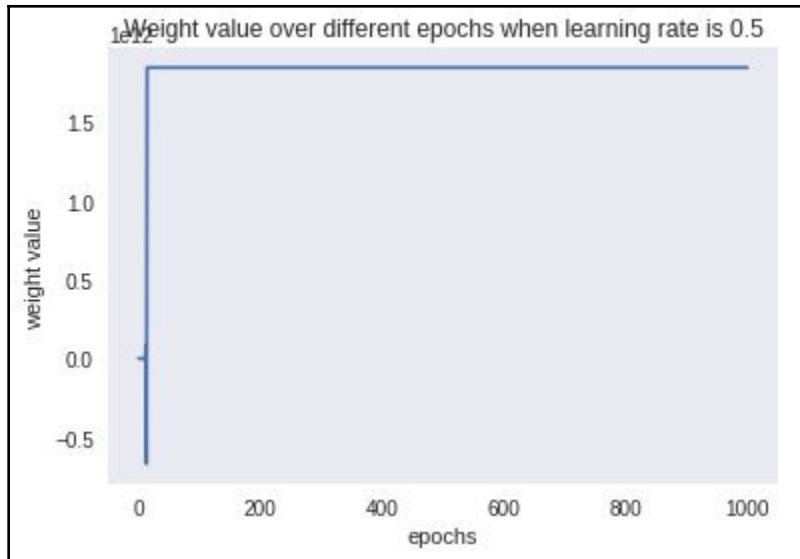

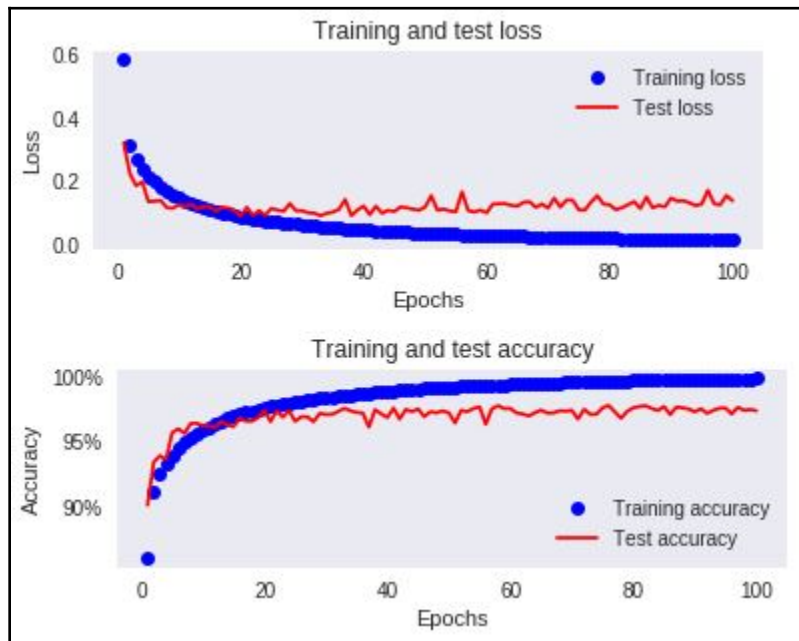
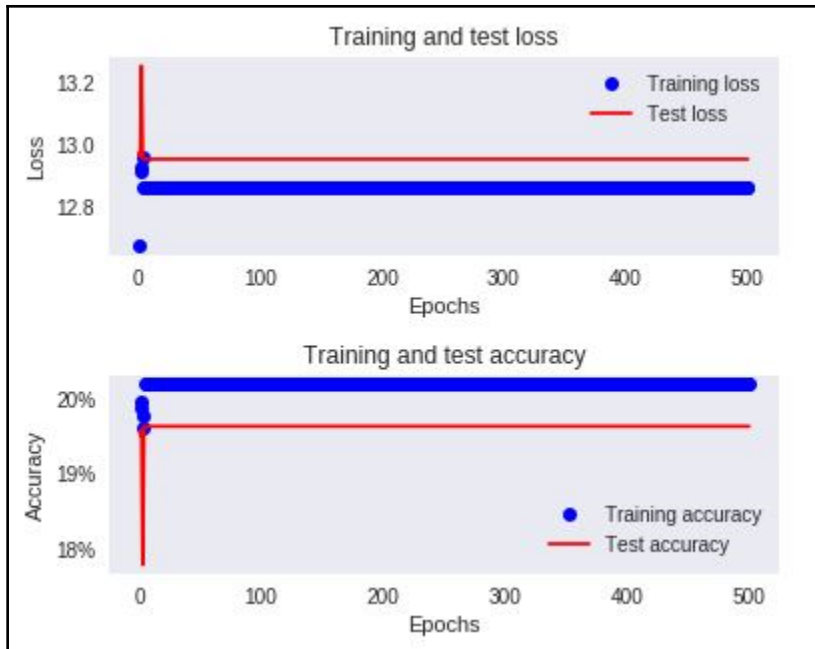



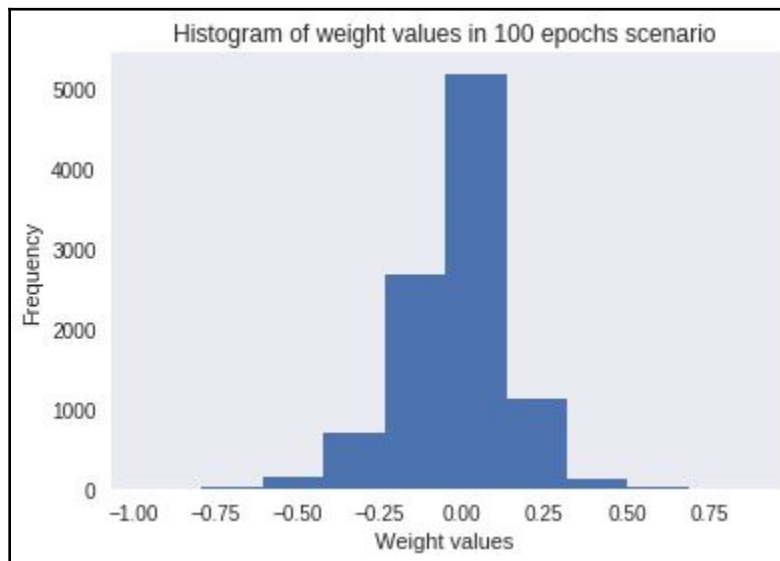
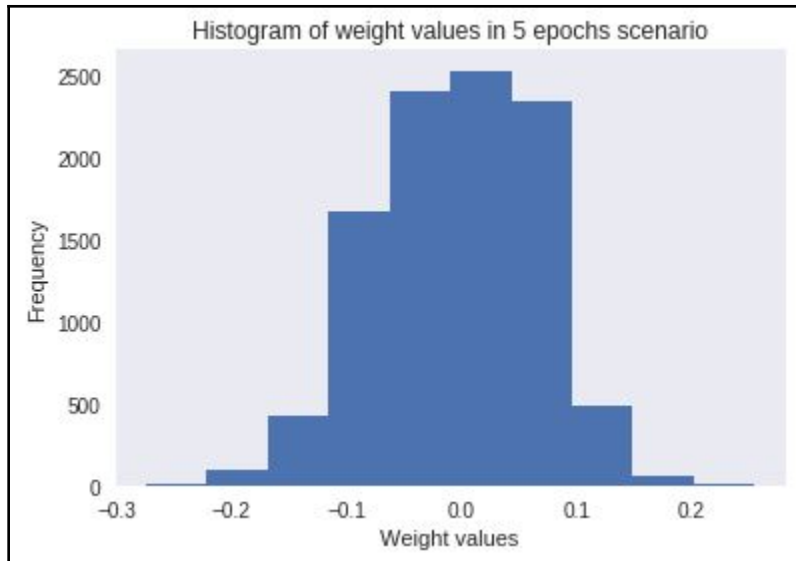

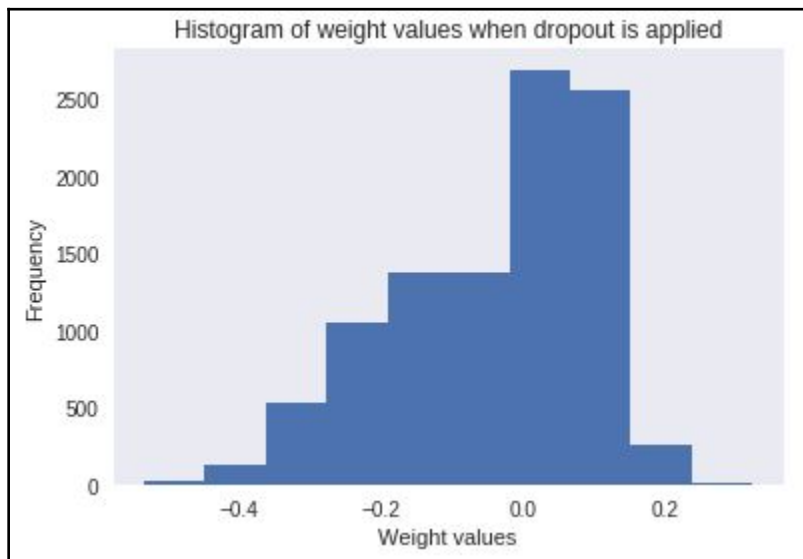
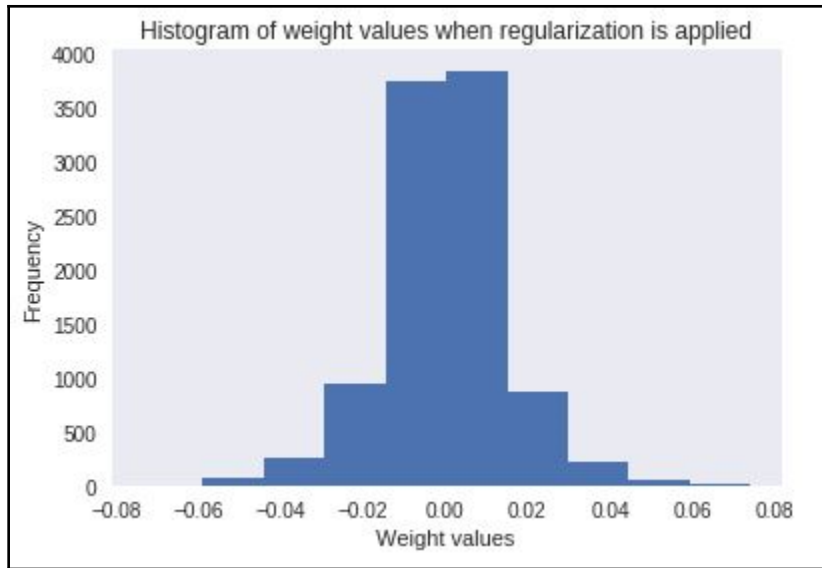

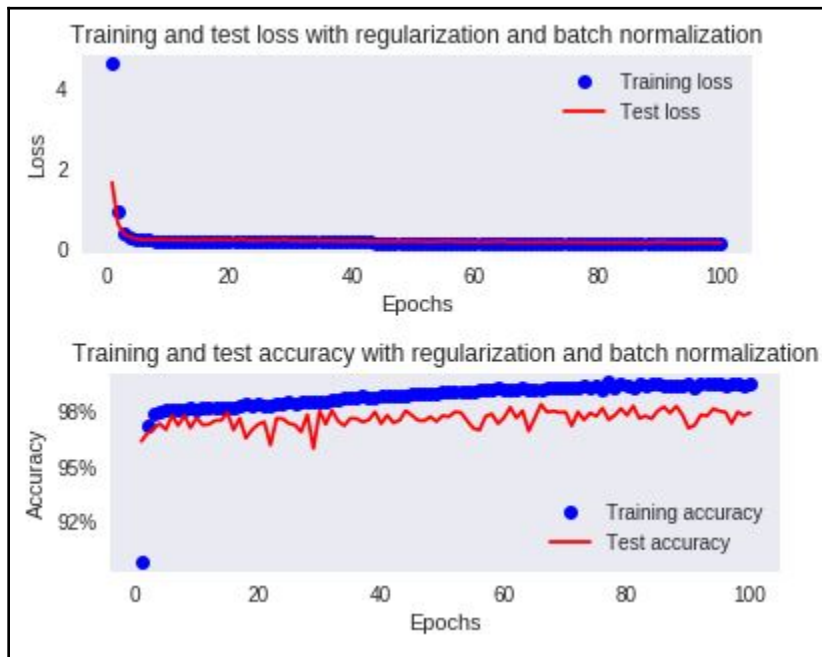
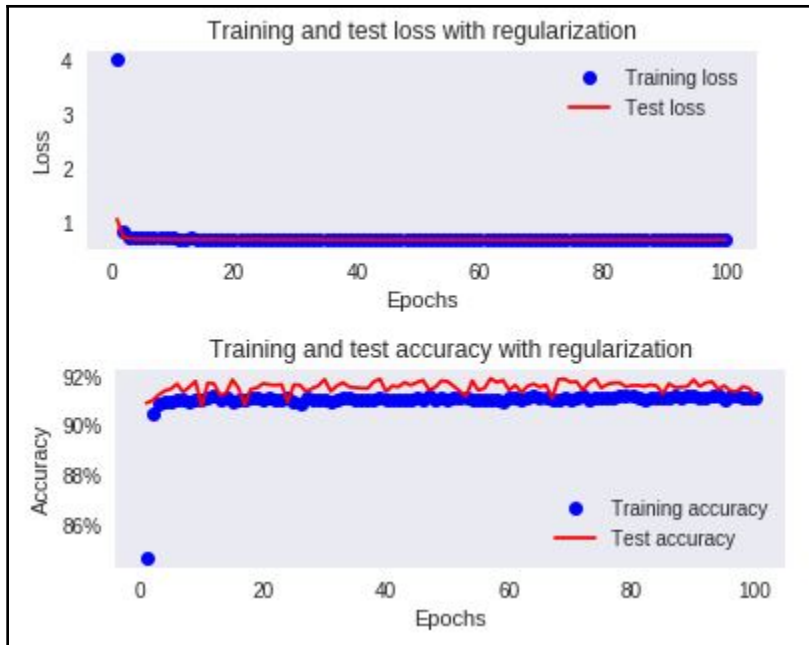

# Chapter 3: Applications of Deep Feedforward Neural Networks

Defaultin2yrs	Age	Debt_income_ratio	Income
0	23	0.4	40000
1	57	2	30000
0	35	0.6	100000

Layer (type)	Output Shape	Param #
dense_5 (Dense)	(None, 1000)	22000
dense_6 (Dense)	(None, 1)	1001

Total params: 23,001  
Trainable params: 23,001  
Non-trainable params: 0

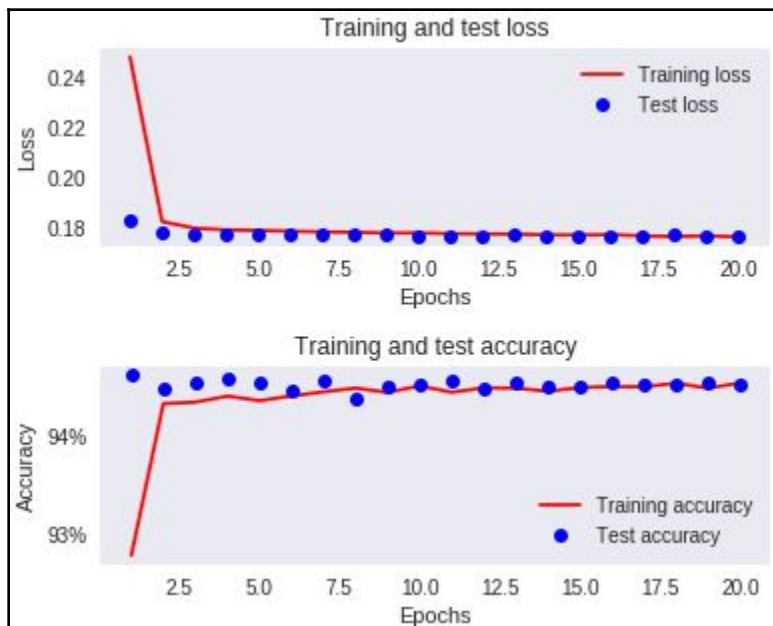



Layer (type)	Output Shape	Param #
dense_7 (Dense)	(None, 64)	896
dense_8 (Dense)	(None, 1)	65
Total params: 961		
Trainable params: 961		
Non-trainable params: 0		

```
[1,
 2,
 2,
 8,
 43,
 10,
 447,
```

Layer (type)	Output Shape	Param #
dense_1 (Dense)	(None, 64)	640064
dense_2 (Dense)	(None, 64)	4160
dense_3 (Dense)	(None, 46)	2990
Total params: 647,214		
Trainable params: 647,214		
Non-trainable params: 0		

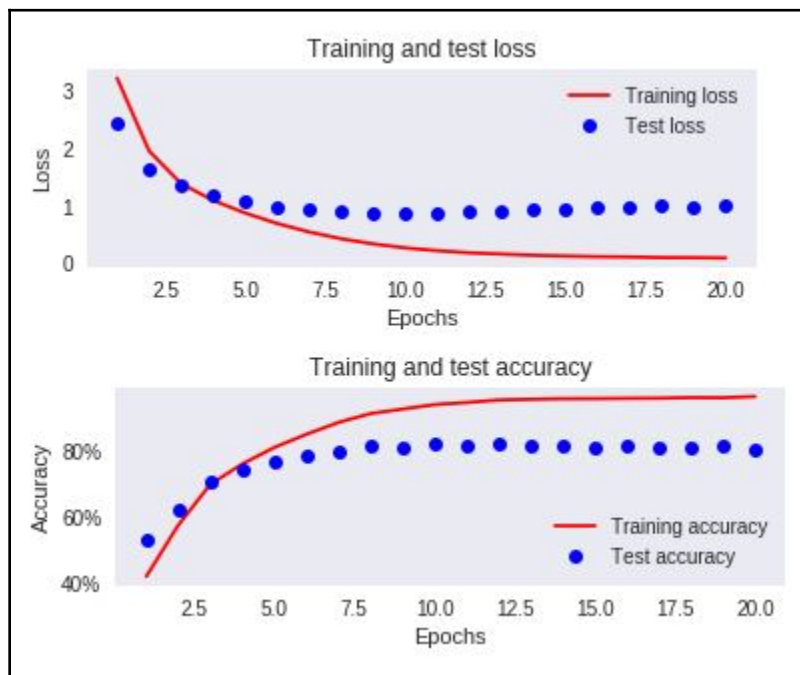

Layer (type)	Output Shape	Param #
dense_1 (Dense)	(None, 1000)	41000
dense_2 (Dense)	(None, 10)	10010
Total params: 51,010		
Trainable params: 51,010		
Non-trainable params: 0		

Layer (type)	Output Shape	Param #
dense_1 (Dense)	(None, 100)	600
dense_2 (Dense)	(None, 1)	101
Total params: 701		
Trainable params: 701		
Non-trainable params: 0		

Layer (type)	Output Shape	Param #	Connected to
input_1 (InputLayer)	(None, 2406)	0	
input_2 (InputLayer)	(None, 5)	0	
dense_1 (Dense)	(None, 100)	240700	input_1[0][0]
dense_3 (Dense)	(None, 100)	600	input_2[0][0]
dense_2 (Dense)	(None, 1)	101	dense_1[0][0]
dense_4 (Dense)	(None, 1)	101	dense_3[0][0]
multiply_1 (Multiply)	(None, 1)	0	dense_2[0][0] dense_4[0][0]
Total params: 241,502			
Trainable params: 241,502			
Non-trainable params: 0			

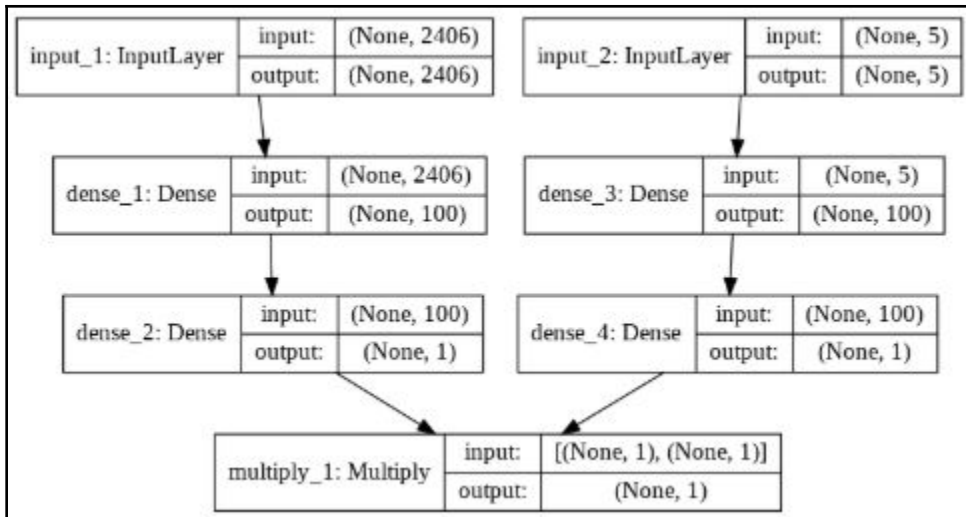



---

## Chapter 4: Building a Deep Convolutional Neural Network

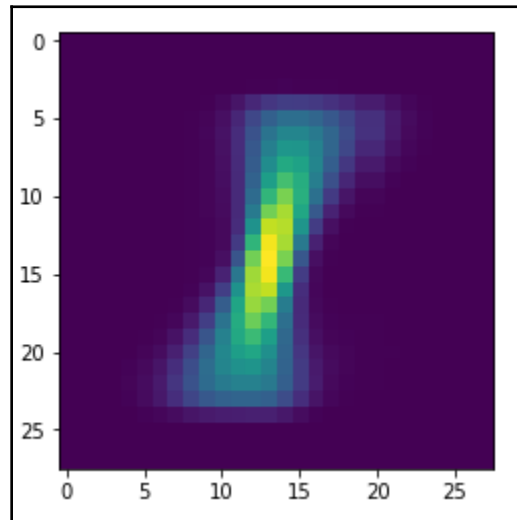
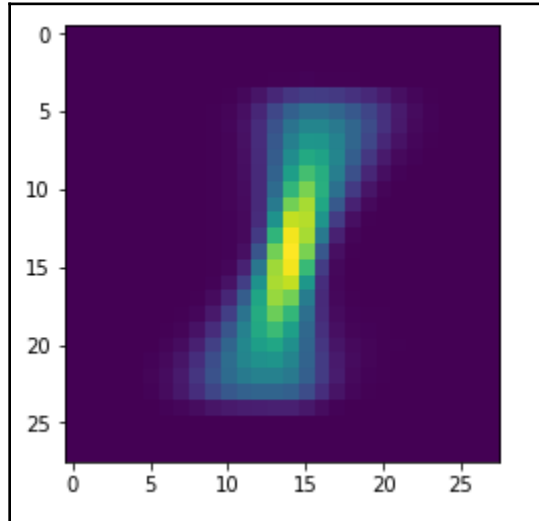

```
array([[2.3734521e-03, 6.3357157e-01, 9.0679098e-03, 2.4509018e-03,  
       7.1080279e-04, 1.9571159e-02, 2.2253724e-02, 1.4216139e-03,  
       3.0820316e-01, 3.7569081e-04]], dtype=float32)
```

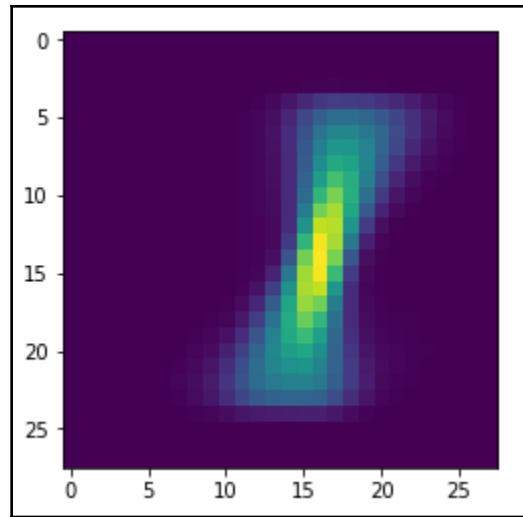

```
array([[0.00117591, 0.18717803, 0.03738188, 0.22529456, 0.07703815,  
       0.00091598, 0.00041914, 0.40253484, 0.03939882, 0.02866266]],  
      dtype=float32)
```

1	2	3	4
5	6	7	8
9	10	11	12
13	14	15	16

1	2
3	4

44	54	64
84	94	104
124	134	144

11	22
32	65

11	22	1	2
32	65	3	4
11	12	25	63
13	14	45	32

11	22	1	2
32	65	3	4
11	12	25	63
13	14	45	32

65	4
14	63

Layer (type)	Output Shape	Param #
Convolution_layer (Conv2D)	(None, 2, 2, 1)	10
Pooling_layer (MaxPooling2D)	(None, 1, 1, 1)	0
Flatten_layer (Flatten)	(None, 1)	0
Output_layer (Dense)	(None, 1)	2
=====		
Total params: 12		
Trainable params: 12		
Non-trainable params: 0		

```
[<tf.Variable 'Convolution_layer_2/kernel:0' shape=(3, 3, 1, 1) dtype=float32_ref>,
<tf.Variable 'Convolution_layer_2/bias:0' shape=(1,) dtype=float32_ref>,
<tf.Variable 'Output_layer_1/kernel:0' shape=(1, 1) dtype=float32_ref>,
<tf.Variable 'Output_layer_1/bias:0' shape=(1,) dtype=float32_ref>]
```

```
array([[0.04289691]], dtype=float32)
```

```
array([[0.04289691]], dtype=float32)
```

Layer (type)	Output Shape	Param #
conv2d_1 (Conv2D)	(None, 26, 26, 10)	100
max_pooling2d_1 (MaxPooling2)	(None, 13, 13, 10)	0
flatten_1 (Flatten)	(None, 1690)	0
dense_1 (Dense)	(None, 1000)	1691000
dense_2 (Dense)	(None, 10)	10010
Total params: 1,701,110		
Trainable params: 1,701,110		
Non-trainable params: 0		

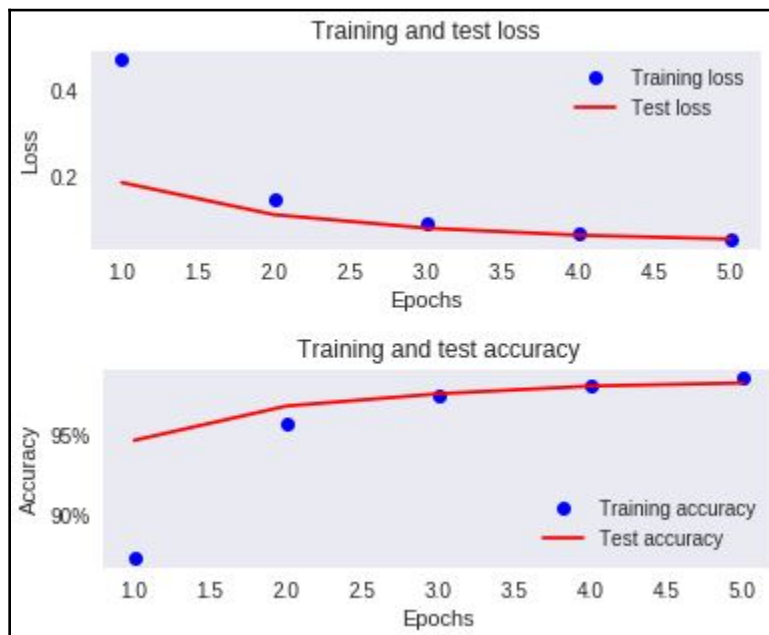

```
array([[5.3325198e-03, 9.5413315e-01, 1.1513928e-02, 2.7472648e-04,
        1.3497858e-03, 1.1531125e-03, 7.3857987e-03, 1.9941789e-03,
        1.6599722e-02, 2.6304892e-04]], dtype=float32)
```

	_unit_id	image_url	please_select_the_gender_of_the_person_in_the_picture
0	1023132475	<a href="https://d1qb2nb5cznatu.cloudfront.net/users/40...">https://d1qb2nb5cznatu.cloudfront.net/users/40...</a>	male
1	1023132476	<a href="https://d1qb2nb5cznatu.cloudfront.net/users/42...">https://d1qb2nb5cznatu.cloudfront.net/users/42...</a>	male
2	1023132477	<a href="https://d1qb2nb5cznatu.cloudfront.net/users/44...">https://d1qb2nb5cznatu.cloudfront.net/users/44...</a>	male
3	1023132478	<a href="https://d1qb2nb5cznatu.cloudfront.net/users/47...">https://d1qb2nb5cznatu.cloudfront.net/users/47...</a>	male
4	1023132479	<a href="https://d1qb2nb5cznatu.cloudfront.net/users/50...">https://d1qb2nb5cznatu.cloudfront.net/users/50...</a>	male

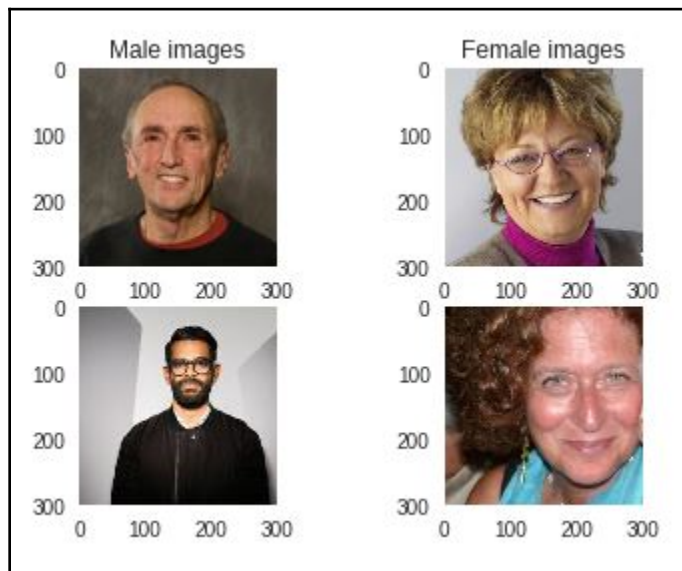

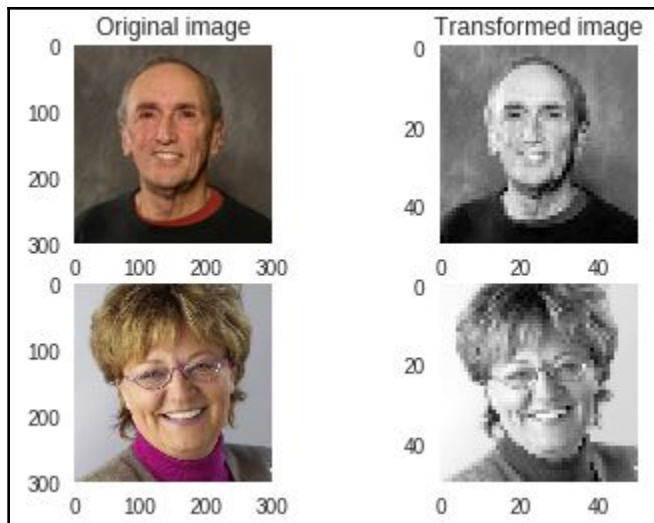

```

[[82, 87, 80, ..., 76, 77, 77],
 [79, 80, 86, ..., 75, 77, 74],
 [84, 79, 73, ..., 73, 75, 75],
 ...,
 [28, 26, 19, ..., 16, 16, 15],
 [14, 24, 15, ..., 12, 14, 13],
 [12, 20, 13, ..., 12, 13, 13]].

```

```
(1591, 50, 50, 1) (177, 50, 50, 1) (1591,) (177,)
```

Layer (type)	Output Shape	Param #
conv2d_38 (Conv2D)	(None, 48, 48, 64)	640
max_pooling2d_28 (MaxPooling)	(None, 9, 9, 64)	0
conv2d_39 (Conv2D)	(None, 9, 9, 128)	73856
max_pooling2d_29 (MaxPooling)	(None, 4, 4, 128)	0
conv2d_40 (Conv2D)	(None, 4, 4, 256)	295168
max_pooling2d_30 (MaxPooling)	(None, 2, 2, 256)	0
conv2d_41 (Conv2D)	(None, 2, 2, 512)	1180160
flatten_10 (Flatten)	(None, 2048)	0
dense_19 (Dense)	(None, 100)	204900
dense_20 (Dense)	(None, 1)	101
=====		
Total params: 1,754,825		
Trainable params: 1,754,825		
Non-trainable params: 0		

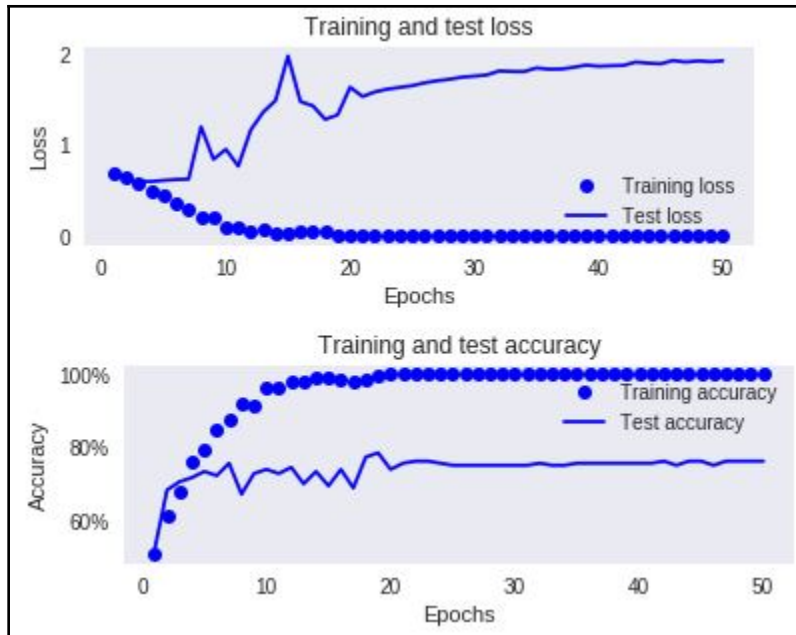



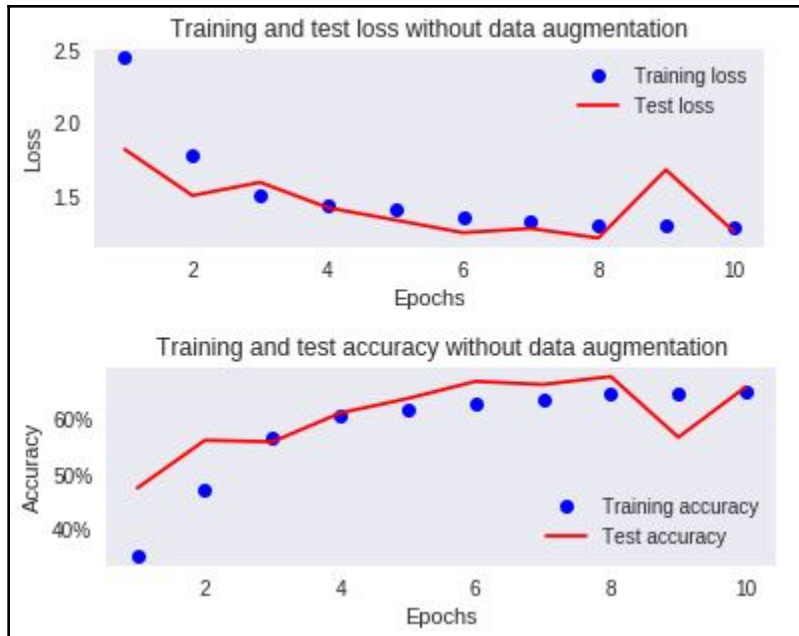

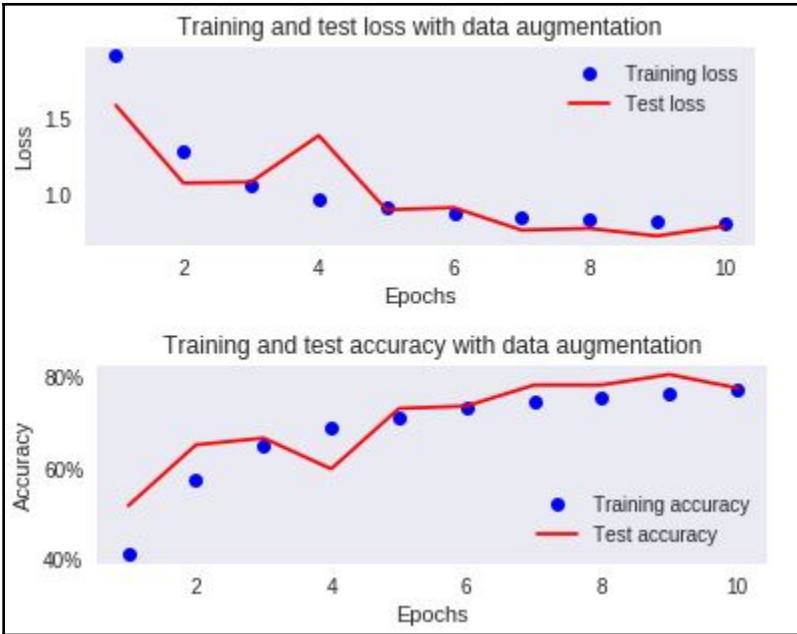

---

# Chapter 5: Transfer Learning

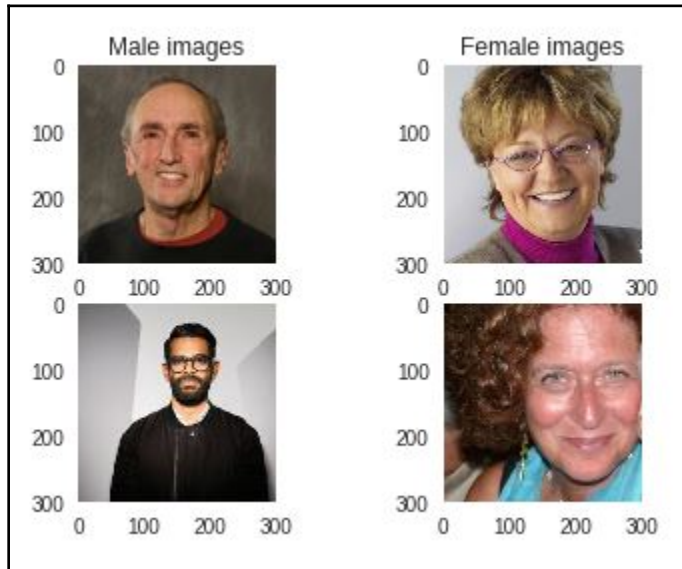

---

Layer (type)	Output Shape	Param #
conv2d_1 (Conv2D)	(None, 298, 298, 64)	1792
max_pooling2d_1 (MaxPooling2D)	(None, 149, 149, 64)	0
conv2d_2 (Conv2D)	(None, 149, 149, 128)	73856
max_pooling2d_2 (MaxPooling2D)	(None, 74, 74, 128)	0
conv2d_3 (Conv2D)	(None, 74, 74, 256)	295168
max_pooling2d_3 (MaxPooling2D)	(None, 37, 37, 256)	0
conv2d_4 (Conv2D)	(None, 37, 37, 512)	1180160
flatten_1 (Flatten)	(None, 700928)	0
dense_1 (Dense)	(None, 100)	70092900
dense_2 (Dense)	(None, 1)	101
Total params: 71,643,977		
Trainable params: 71,643,977		
Non-trainable params: 0		

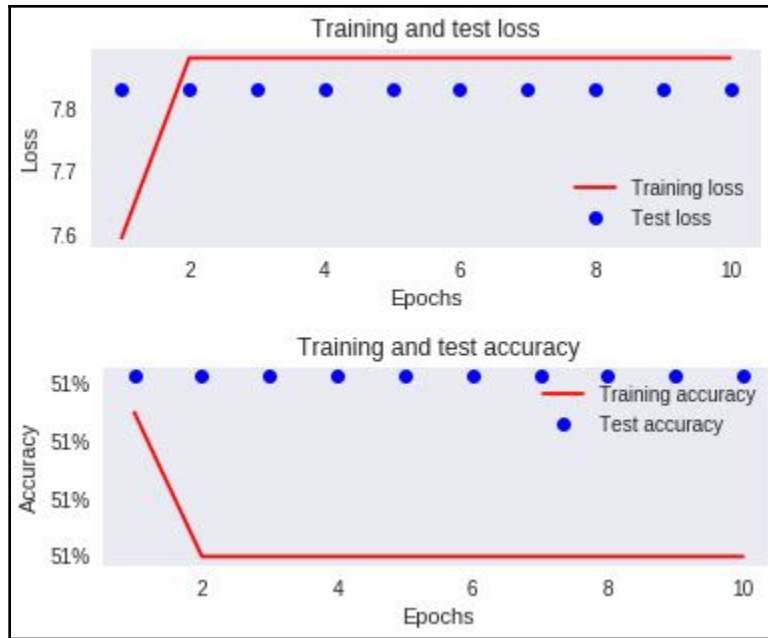

Layer (type)	Output Shape	Param #
conv2d_5 (Conv2D)	(None, 48, 48, 64)	1792
max_pooling2d_4 (MaxPooling2D)	(None, 24, 24, 64)	0
conv2d_6 (Conv2D)	(None, 24, 24, 128)	73856
max_pooling2d_5 (MaxPooling2D)	(None, 12, 12, 128)	0
conv2d_7 (Conv2D)	(None, 12, 12, 256)	295168
max_pooling2d_6 (MaxPooling2D)	(None, 6, 6, 256)	0
conv2d_8 (Conv2D)	(None, 6, 6, 512)	1180160
flatten_2 (Flatten)	(None, 18432)	0
dense_3 (Dense)	(None, 100)	1843300
dense_4 (Dense)	(None, 1)	101
Total params: 3,394,377		
Trainable params: 3,394,377		
Non-trainable params: 0		



Layer (type)	Output Shape	Param #
conv2d_9 (Conv2D)	(None, 298, 298, 64)	1792
max_pooling2d_7 (MaxPooling2D)	(None, 99, 99, 64)	0
conv2d_10 (Conv2D)	(None, 99, 99, 128)	73856
max_pooling2d_8 (MaxPooling2D)	(None, 33, 33, 128)	0
conv2d_11 (Conv2D)	(None, 33, 33, 256)	295168
max_pooling2d_9 (MaxPooling2D)	(None, 11, 11, 256)	0
conv2d_12 (Conv2D)	(None, 11, 11, 512)	1180160
flatten_3 (Flatten)	(None, 61952)	0
dense_5 (Dense)	(None, 100)	6195300
dense_6 (Dense)	(None, 1)	101
Total params: 7,746,377		
Trainable params: 7,746,377		
Non-trainable params: 0		





Layer (type)	Output Shape	Param #
input_1 (InputLayer)	(None, 300, 300, 3)	0
block1_conv1 (Conv2D)	(None, 300, 300, 64)	1792
block1_conv2 (Conv2D)	(None, 300, 300, 64)	36928
block1_pool (MaxPooling2D)	(None, 150, 150, 64)	0
block2_conv1 (Conv2D)	(None, 150, 150, 128)	73856
block2_conv2 (Conv2D)	(None, 150, 150, 128)	147584
block2_pool (MaxPooling2D)	(None, 75, 75, 128)	0
block3_conv1 (Conv2D)	(None, 75, 75, 256)	295168
block3_conv2 (Conv2D)	(None, 75, 75, 256)	590080
block3_conv3 (Conv2D)	(None, 75, 75, 256)	590080
block3_pool (MaxPooling2D)	(None, 37, 37, 256)	0
block4_conv1 (Conv2D)	(None, 37, 37, 512)	1180160
block4_conv2 (Conv2D)	(None, 37, 37, 512)	2359808
block4_conv3 (Conv2D)	(None, 37, 37, 512)	2359808
block4_pool (MaxPooling2D)	(None, 18, 18, 512)	0
block5_conv1 (Conv2D)	(None, 18, 18, 512)	2359808
block5_conv2 (Conv2D)	(None, 18, 18, 512)	2359808
block5_conv3 (Conv2D)	(None, 18, 18, 512)	2359808
block5_pool (MaxPooling2D)	(None, 9, 9, 512)	0
=====		
Total params: 14,714,688		
Trainable params: 14,714,688		
Non-trainable params: 0		

Layer (type)	Output Shape	Param #
conv2d_14 (Conv2D)	(None, 7, 7, 512)	2359808
max_pooling2d_11 (MaxPooling)	(None, 3, 3, 512)	0
flatten_5 (Flatten)	(None, 4608)	0
dense_9 (Dense)	(None, 512)	2359808
dropout_2 (Dropout)	(None, 512)	0
dense_10 (Dense)	(None, 1)	513
=====		
Total params: 4,720,129		
Trainable params: 4,720,129		
Non-trainable params: 0		

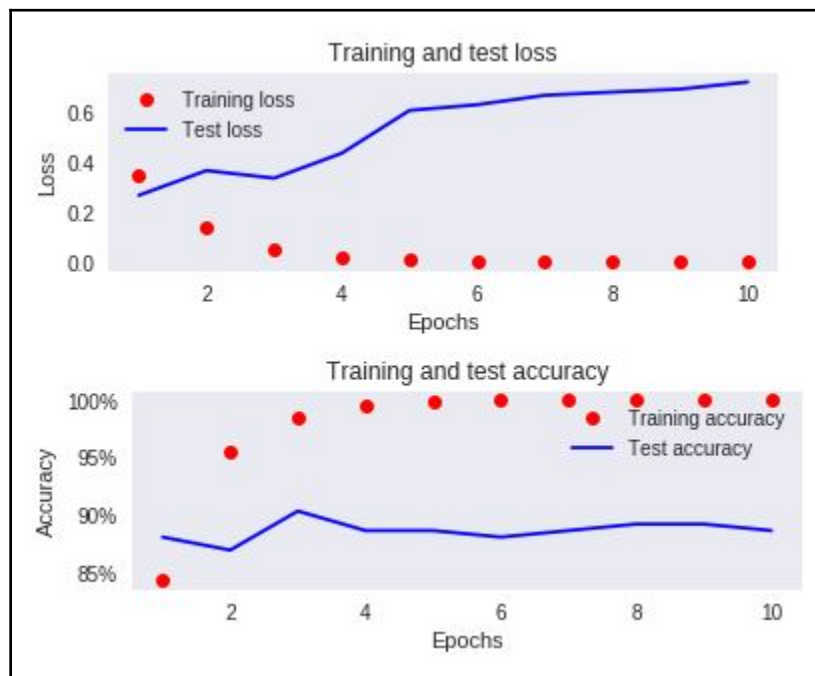

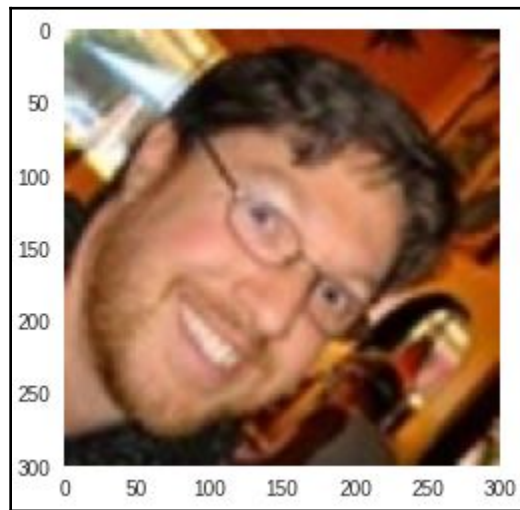
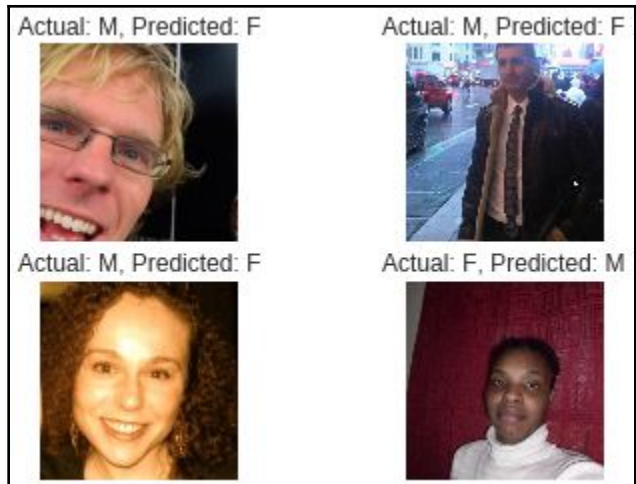

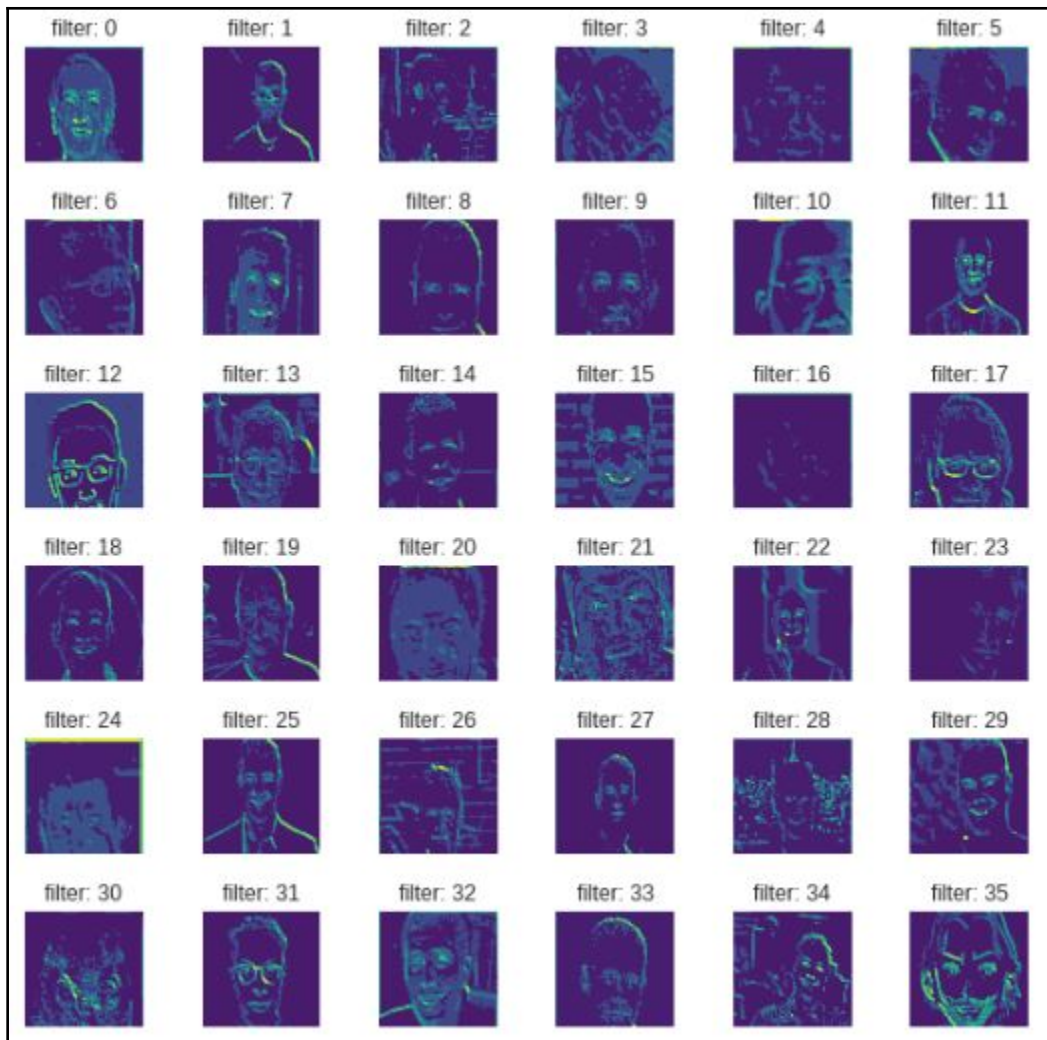

---

```
0 conv2d_1
1 conv2d_2
2 max_pooling2d_1
3 dropout_1
4 conv2d_3
5 conv2d_4
6 max_pooling2d_2
7 dropout_2
8 conv2d_5
9 conv2d_6
10 dropout_3
11 flatten_1
12 dense_1
13 dropout_4
14 dense_2
```

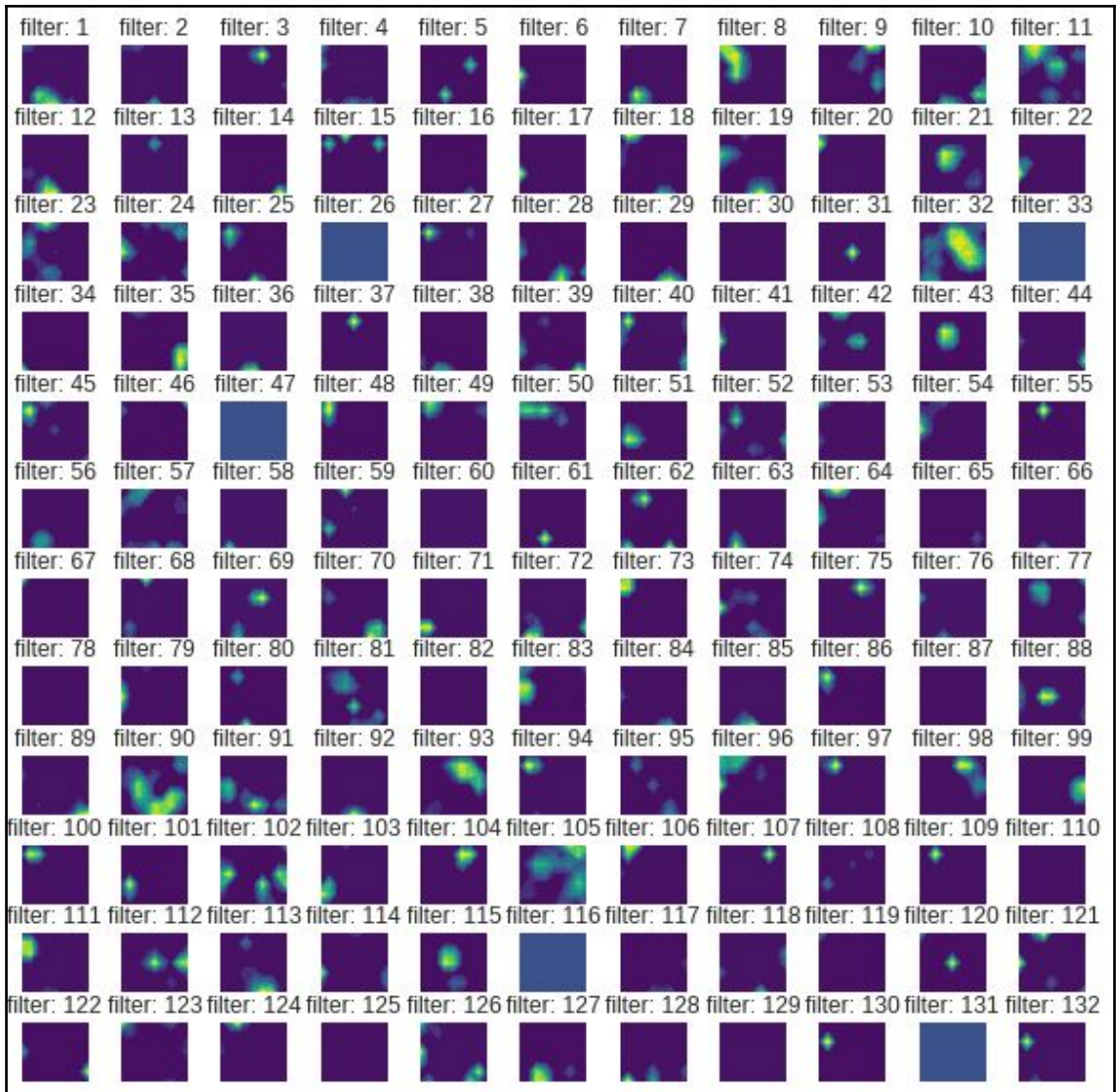

Layer (type)	Output Shape	Param #
input_1 (InputLayer)	(None, 300, 300, 3)	0
block1_conv1 (Conv2D)	(None, 300, 300, 64)	1792
block1_conv2 (Conv2D)	(None, 300, 300, 64)	36928
block1_pool (MaxPooling2D)	(None, 150, 150, 64)	0
block2_conv1 (Conv2D)	(None, 150, 150, 128)	73856
block2_conv2 (Conv2D)	(None, 150, 150, 128)	147584
block2_pool (MaxPooling2D)	(None, 75, 75, 128)	0
block3_conv1 (Conv2D)	(None, 75, 75, 256)	295168
block3_conv2 (Conv2D)	(None, 75, 75, 256)	590080
block3_conv3 (Conv2D)	(None, 75, 75, 256)	590080
block3_pool (MaxPooling2D)	(None, 37, 37, 256)	0
block4_conv1 (Conv2D)	(None, 37, 37, 512)	1180160
block4_conv2 (Conv2D)	(None, 37, 37, 512)	2359808
block4_conv3 (Conv2D)	(None, 37, 37, 512)	2359808
block4_pool (MaxPooling2D)	(None, 18, 18, 512)	0
block5_conv1 (Conv2D)	(None, 18, 18, 512)	2359808
block5_conv2 (Conv2D)	(None, 18, 18, 512)	2359808
block5_conv3 (Conv2D)	(None, 18, 18, 512)	2359808
block5_pool (MaxPooling2D)	(None, 9, 9, 512)	0
=====		
Total params: 14,714,688		
Trainable params: 14,714,688		
Non-trainable params: 0		



Layer (type)	Output Shape	Param #
conv2d_6 (Conv2D)	(None, 7, 7, 512)	2359808
max_pooling2d_5 (MaxPooling2)	(None, 3, 3, 512)	0
flatten_3 (Flatten)	(None, 4608)	0
dense_5 (Dense)	(None, 512)	2359808
dropout_2 (Dropout)	(None, 512)	0
dense_6 (Dense)	(None, 1)	513
=====		
Total params: 4,720,129		
Trainable params: 4,720,129		
Non-trainable params: 0		

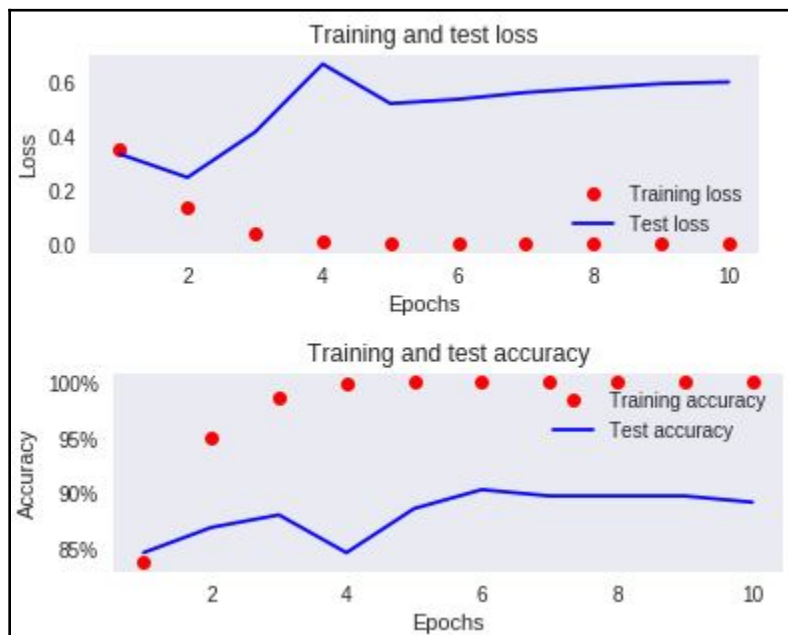

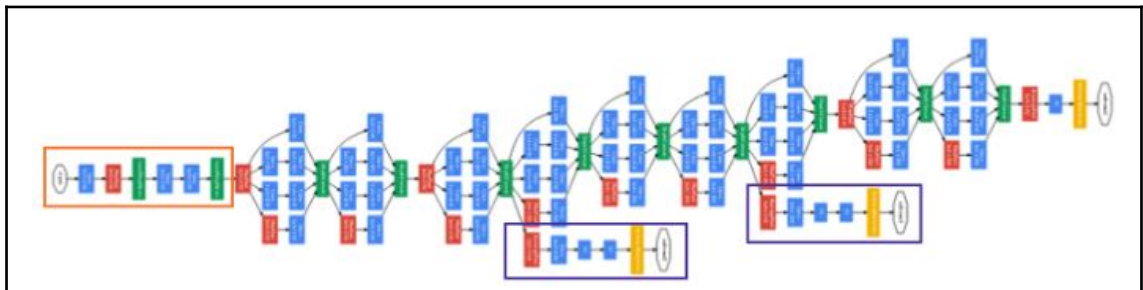
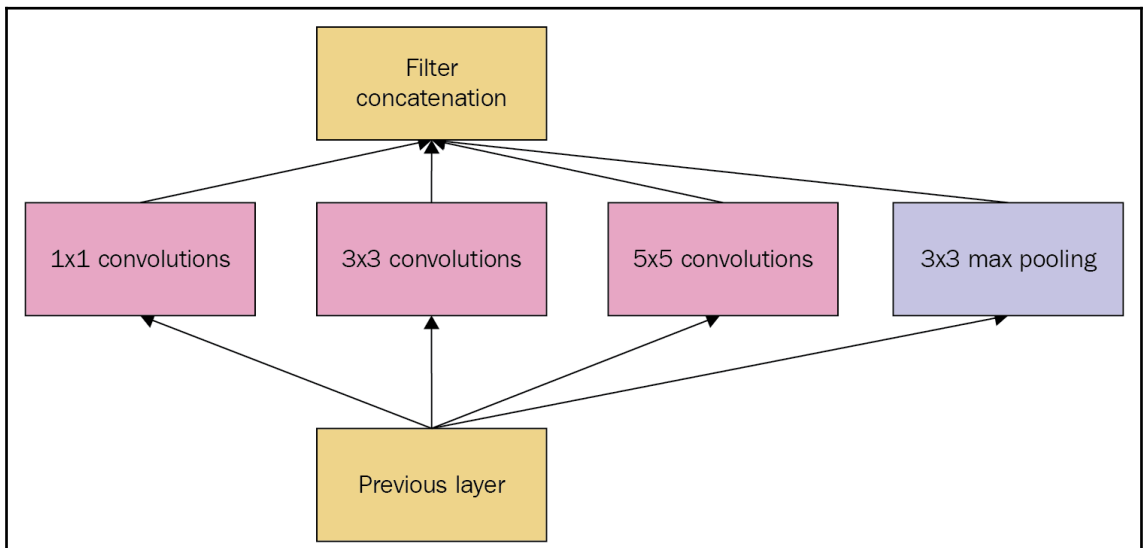
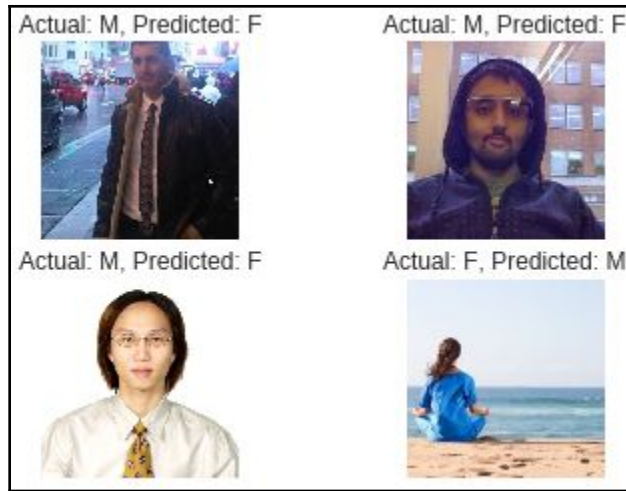

Layer (type)	Output Shape	Param #
conv2d_101 (Conv2D)	(None, 6, 6, 512)	9437696
max_pooling2d_10 (MaxPooling)	(None, 3, 3, 512)	0
flatten_4 (Flatten)	(None, 4608)	0
dense_7 (Dense)	(None, 512)	2359808
dropout_3 (Dropout)	(None, 512)	0
dense_8 (Dense)	(None, 1)	513
=====		
Total params: 11,798,017		
Trainable params: 11,798,017		
Non-trainable params: 0		

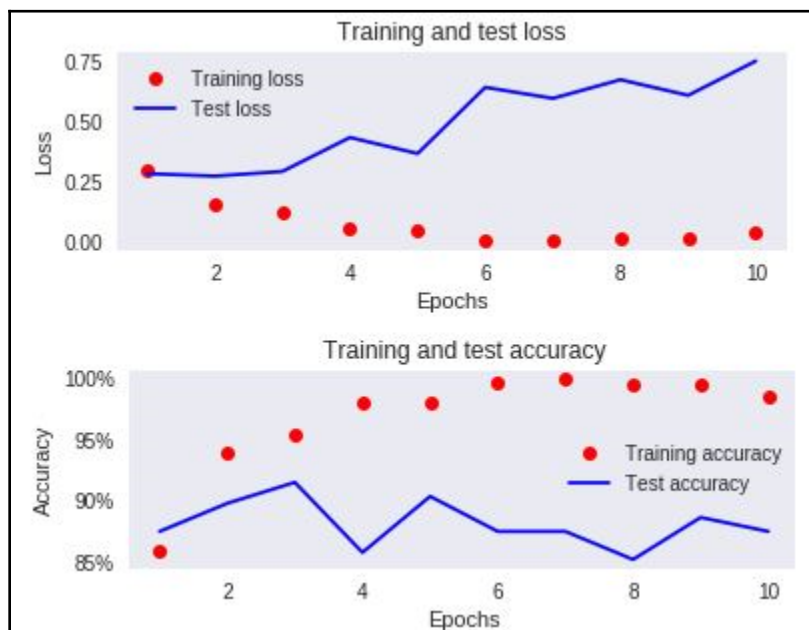

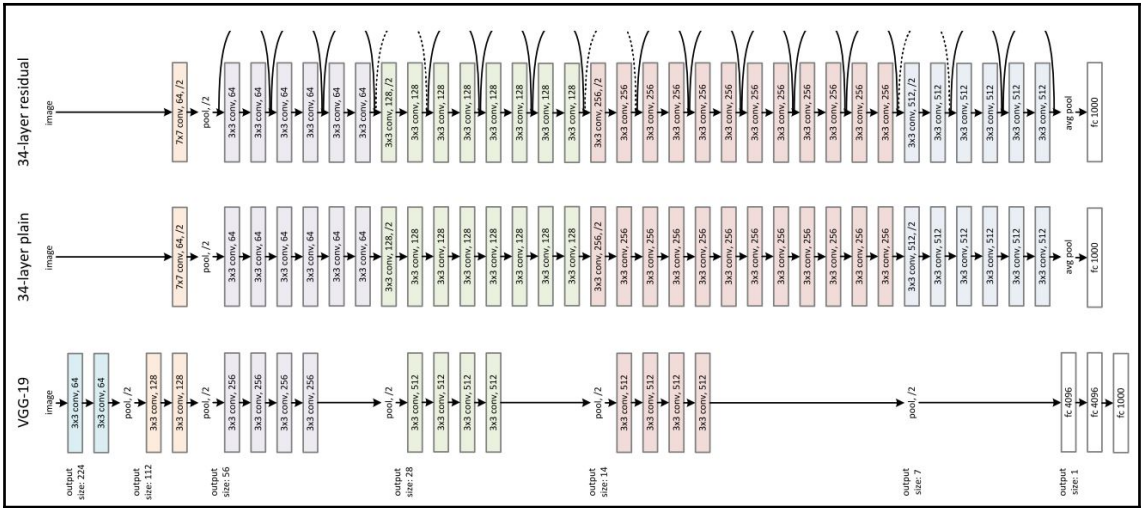

Layer (type)	Output Shape	Param #
conv2d_102 (Conv2D)	(None, 8, 8, 512)	9437696
max_pooling2d_12 (MaxPooling)	(None, 4, 4, 512)	0
conv2d_103 (Conv2D)	(None, 2, 2, 512)	2359808
max_pooling2d_13 (MaxPooling)	(None, 1, 1, 512)	0
flatten_5 (Flatten)	(None, 512)	0
dense_9 (Dense)	(None, 512)	262656
dropout_4 (Dropout)	(None, 512)	0
dense_10 (Dense)	(None, 1)	513
=====		
Total params: 12,060,673		
Trainable params: 12,060,673		
Non-trainable params: 0		

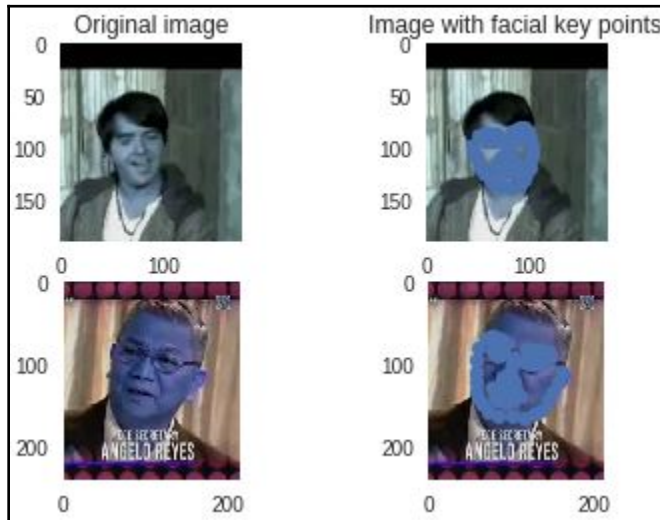

	Unnamed: 0	0	1	2	3	4	5	6	7	8	...	126
0	Luis_Fonsi_21.jpg	45.0	98.0	47.0	106.0	49.0	110.0	53.0	119.0	56.0	...	83.0
1	Lincoln_Chafee_52.jpg	41.0	83.0	43.0	91.0	45.0	100.0	47.0	108.0	51.0	...	85.0
2	Valerie_Harper_30.jpg	56.0	69.0	56.0	77.0	56.0	86.0	56.0	94.0	58.0	...	79.0
3	Angelo_Reyes_22.jpg	61.0	80.0	58.0	95.0	58.0	108.0	58.0	120.0	58.0	...	98.0
4	Kristen_Breitweiser_11.jpg	58.0	94.0	58.0	104.0	60.0	113.0	62.0	121.0	67.0	...	92.0

5 rows x 137 columns

Layer (type)	Output Shape	Param #
conv2d_11 (Conv2D)	(None, 5, 5, 512)	2359808
max_pooling2d_11 (MaxPooling)	(None, 2, 2, 512)	0
flatten_11 (Flatten)	(None, 2048)	0
dense_21 (Dense)	(None, 512)	1049088
dropout_11 (Dropout)	(None, 512)	0
dense_22 (Dense)	(None, 136)	69768
=====		
Total params: 3,478,664		
Trainable params: 3,478,664		
Non-trainable params: 0		

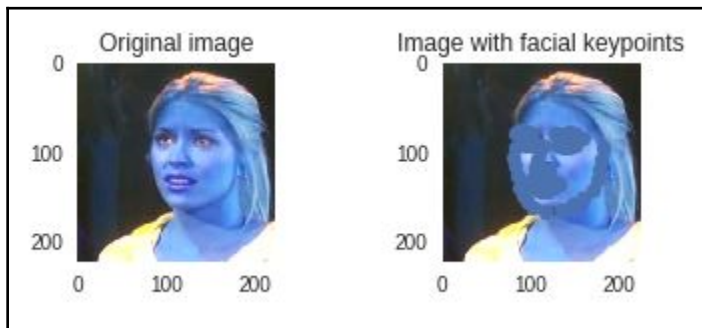
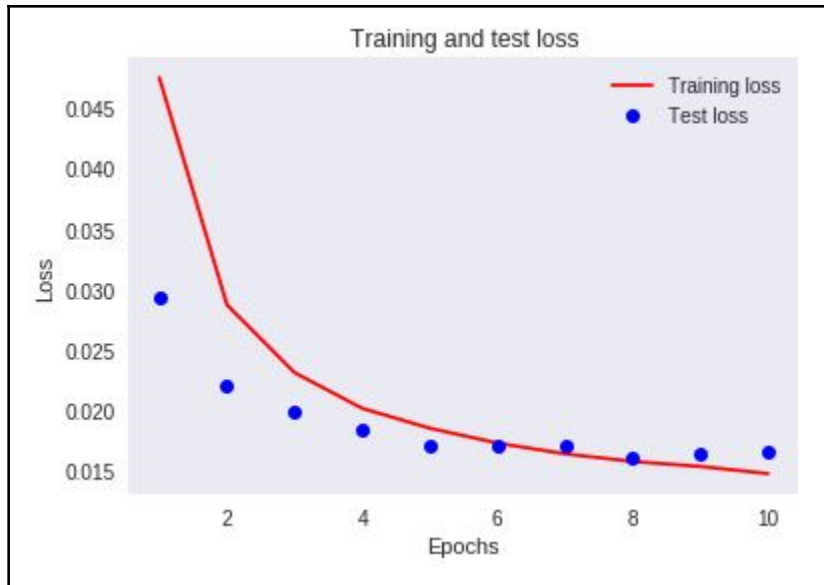

# Chapter 6: Detecting and Localizing Objects in Images

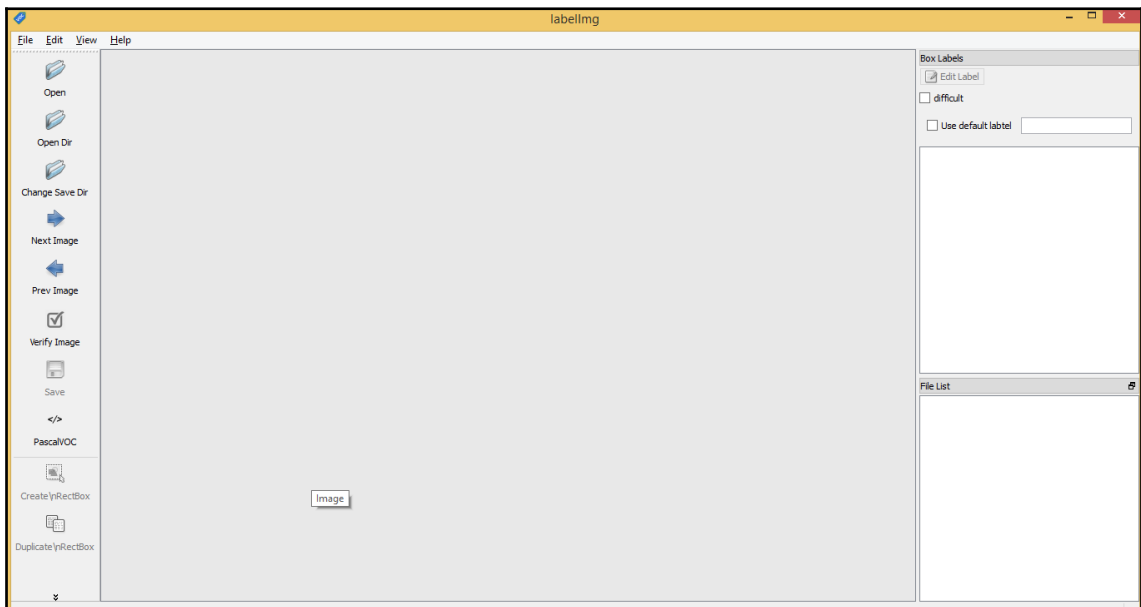
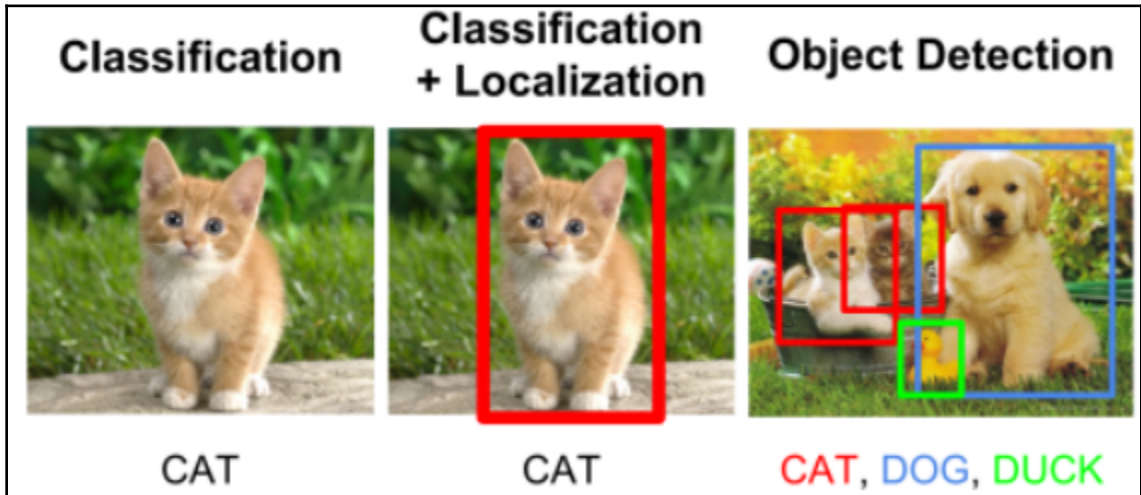



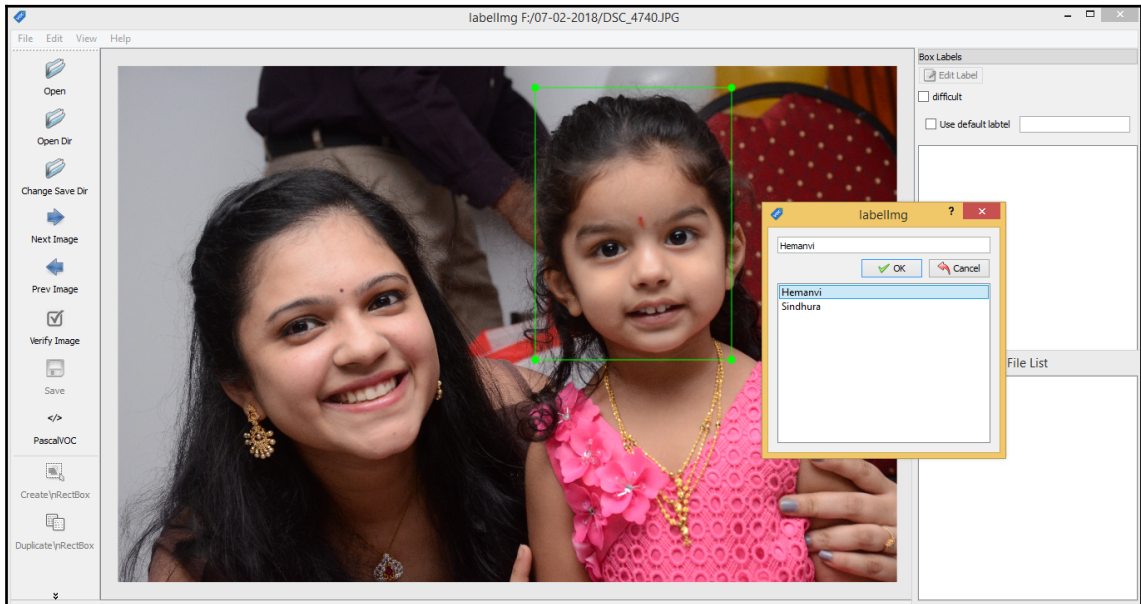
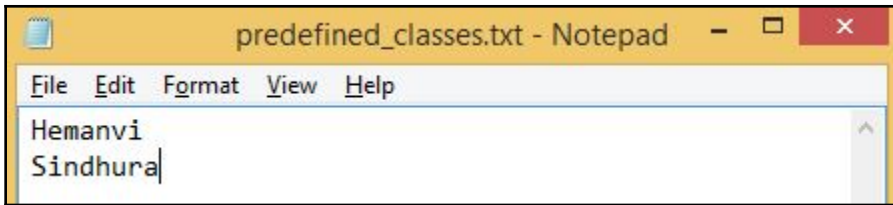

```
<annotation>
  <folder>07-02-2018</folder>
  <filename>DSC_4740.JPG</filename>
  <path>F:/07-02-2018/DSC_4740.JPG</path>
  <source>
    <database>Unknown</database>
  </source>
  <size>
    <width>4928</width>
    <height>3264</height>
    <depth>3</depth>
  </size>
  <segmented>0</segmented>
  <object>
    <name>Hemanvi</name>
    <pose>Unspecified</pose>
    <truncated>0</truncated>
    <difficult>0</difficult>
    <bndbox>
      <xmin>2639</xmin>
      <ymin>136</ymin>
      <xmax>3881</xmax>
      <ymax>1857</ymax>
    </bndbox>
  </object>
  <object>
    <name>Sindhura</name>
    <pose>Unspecified</pose>
    <truncated>0</truncated>
    <difficult>0</difficult>
    <bndbox>
      <xmin>381</xmin>
      <ymin>615</ymin>
      <xmax>2129</xmax>
      <ymax>2494</ymax>
    </bndbox>
  </object>
</annotation>
```

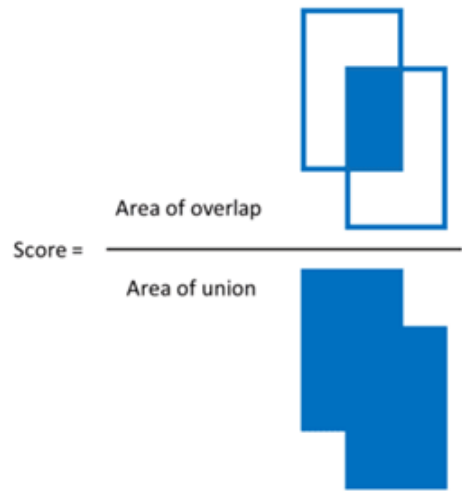
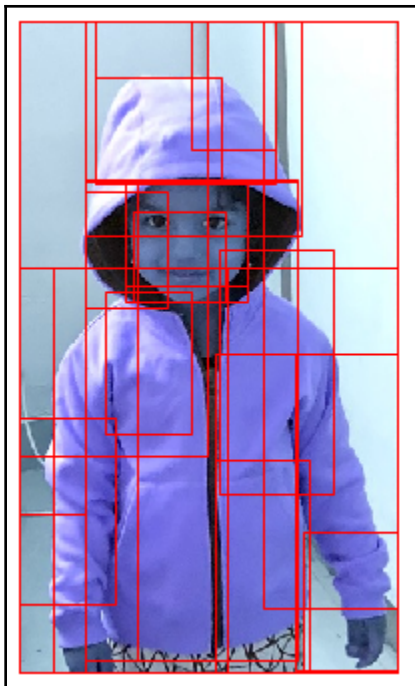

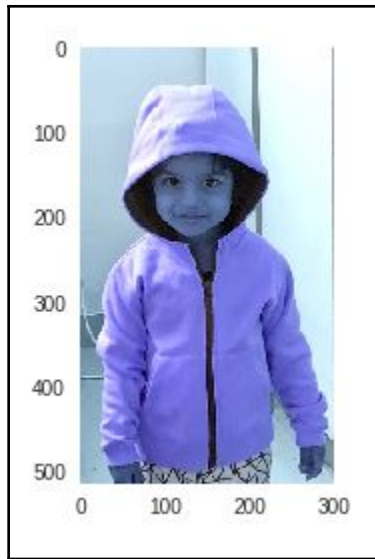

# R-CNN

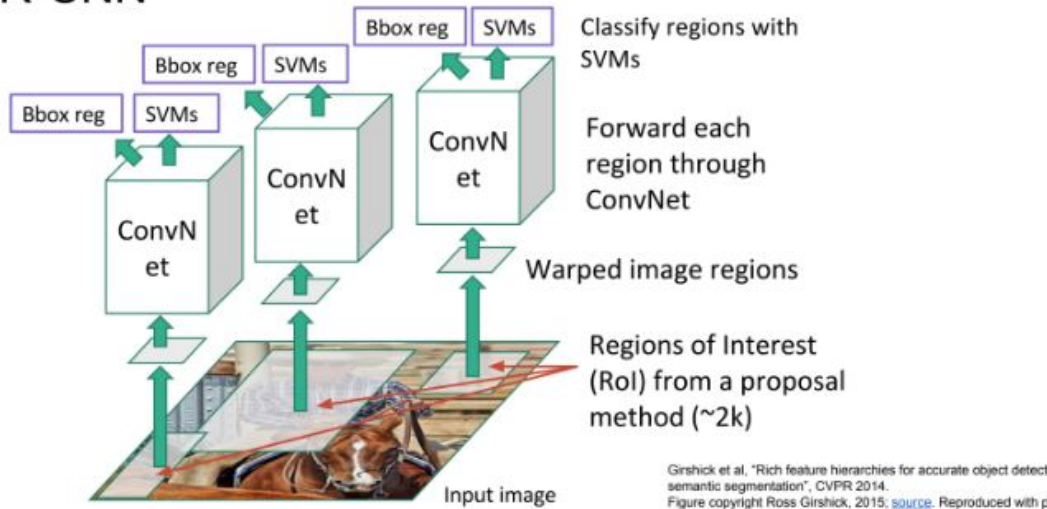

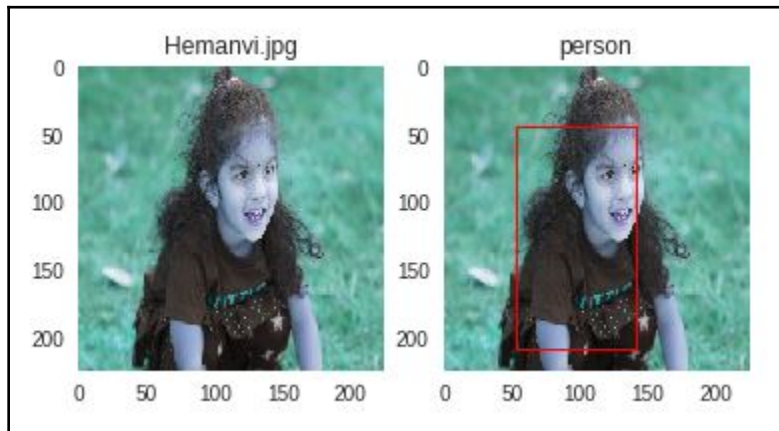
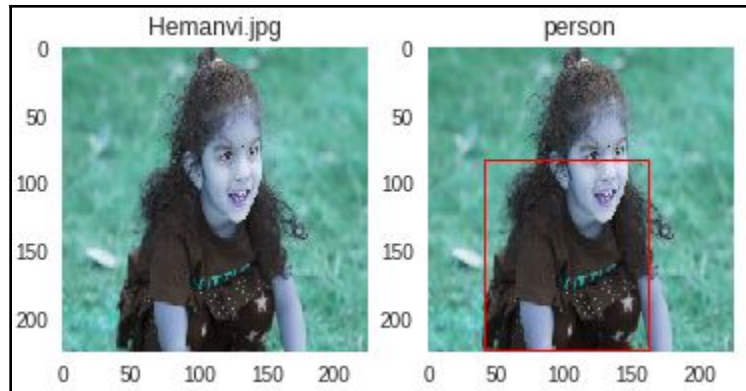



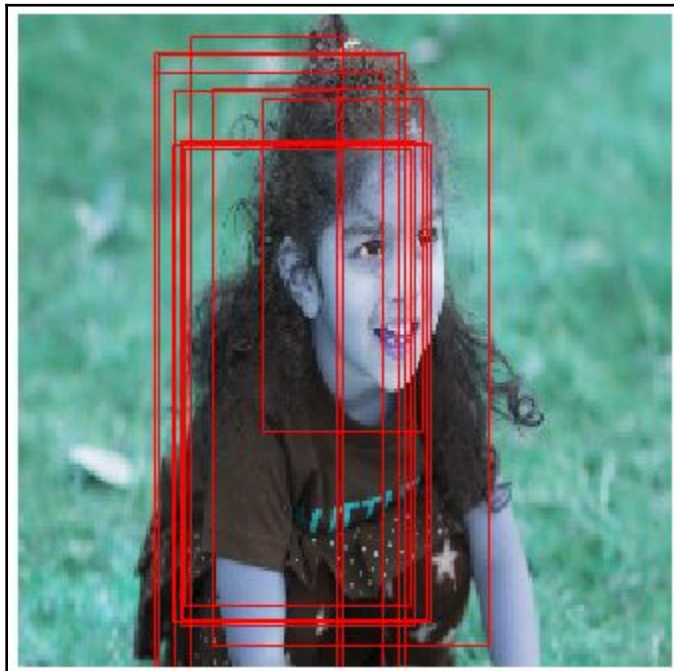
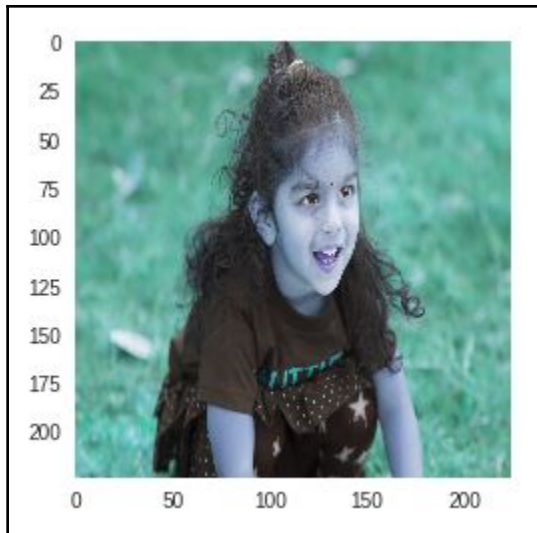

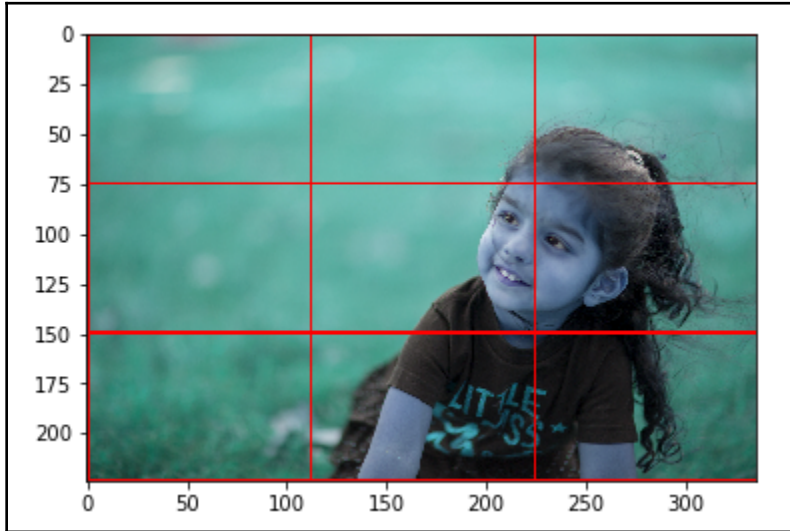
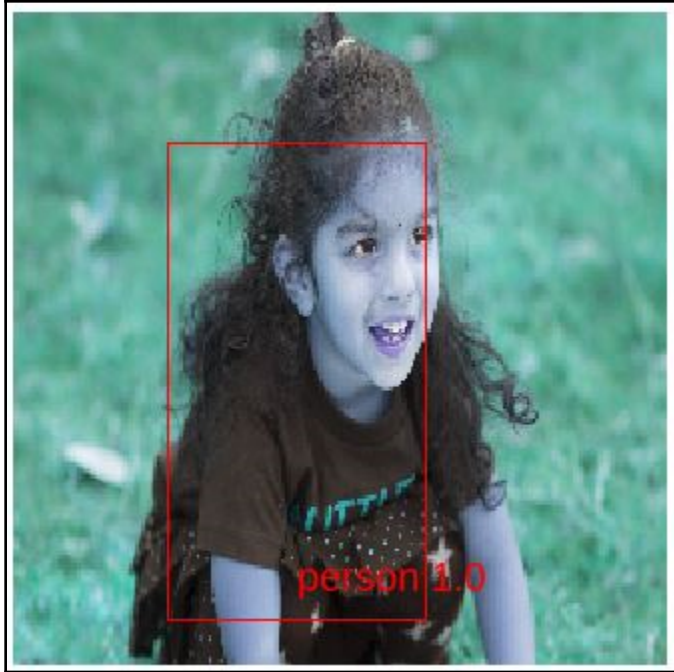



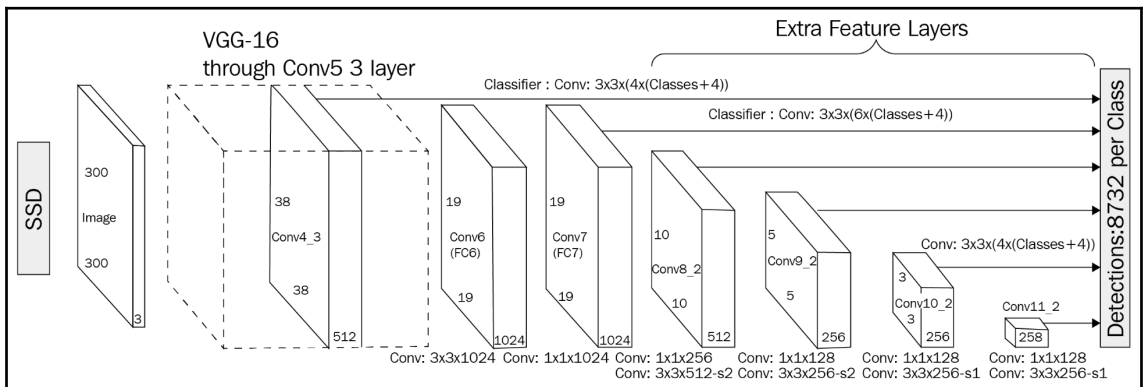
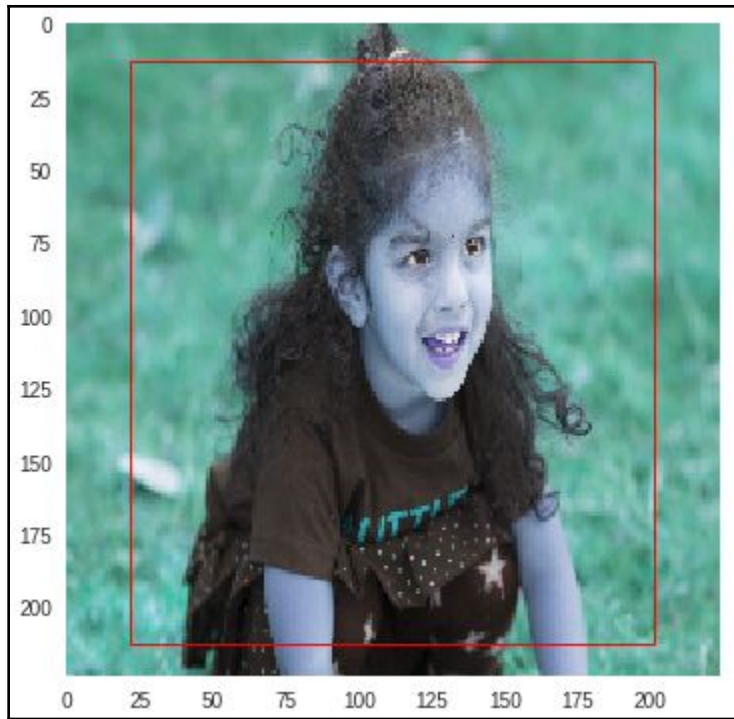

---

# Chapter 7: Image Analysis Applications in Self-Driving Cars

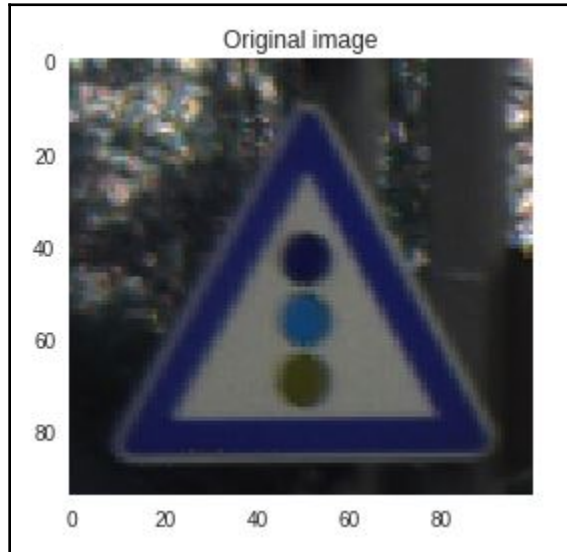
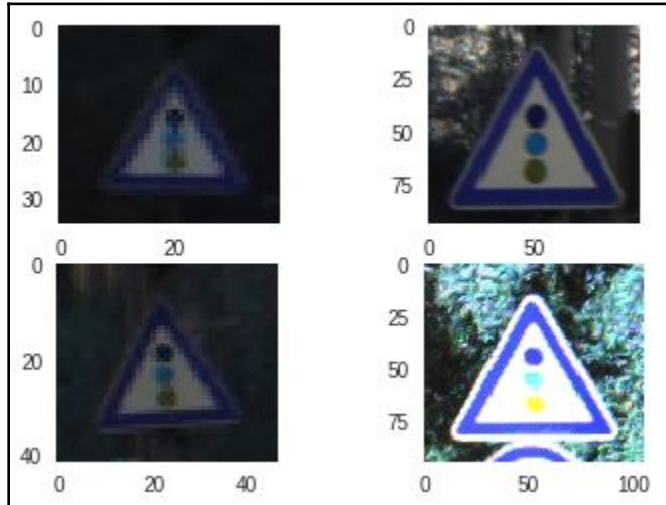

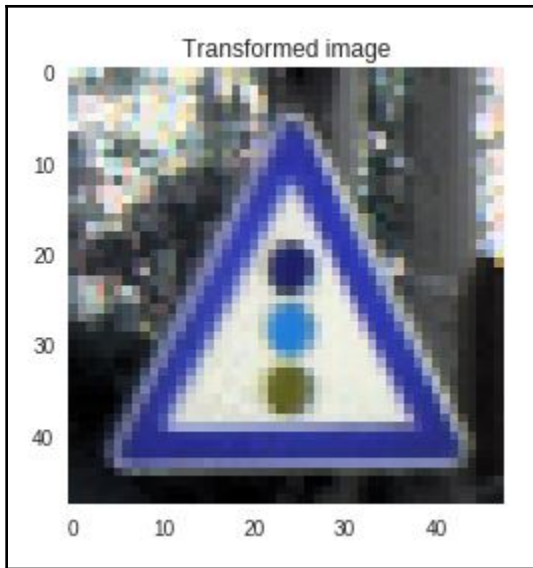

Layer (type)	Output Shape	Param #
conv2d_1 (Conv2D)	(None, 48, 48, 32)	896
conv2d_2 (Conv2D)	(None, 46, 46, 32)	9248
max_pooling2d_1 (MaxPooling2D)	(None, 23, 23, 32)	0
dropout_1 (Dropout)	(None, 23, 23, 32)	0
conv2d_3 (Conv2D)	(None, 23, 23, 64)	18496
conv2d_4 (Conv2D)	(None, 21, 21, 64)	36928
max_pooling2d_2 (MaxPooling2D)	(None, 10, 10, 64)	0
dropout_2 (Dropout)	(None, 10, 10, 64)	0
conv2d_5 (Conv2D)	(None, 10, 10, 128)	73856
conv2d_6 (Conv2D)	(None, 8, 8, 128)	147584
max_pooling2d_3 (MaxPooling2D)	(None, 4, 4, 128)	0
dropout_3 (Dropout)	(None, 4, 4, 128)	0
flatten_1 (Flatten)	(None, 2048)	0
dense_1 (Dense)	(None, 512)	1049088
dropout_4 (Dropout)	(None, 512)	0
dense_2 (Dense)	(None, 43)	22059
=====		
Total params: 1,358,155		
Trainable params: 1,358,155		
Non-trainable params: 0		

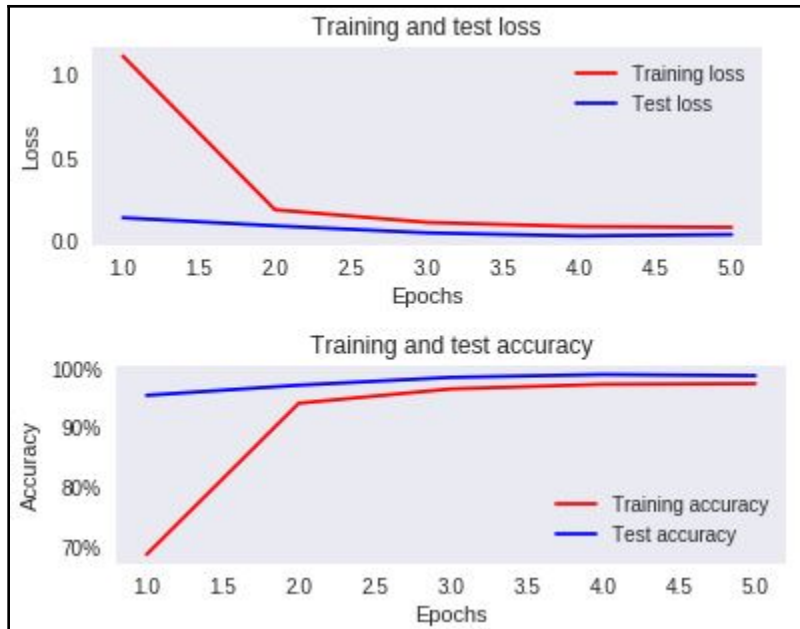

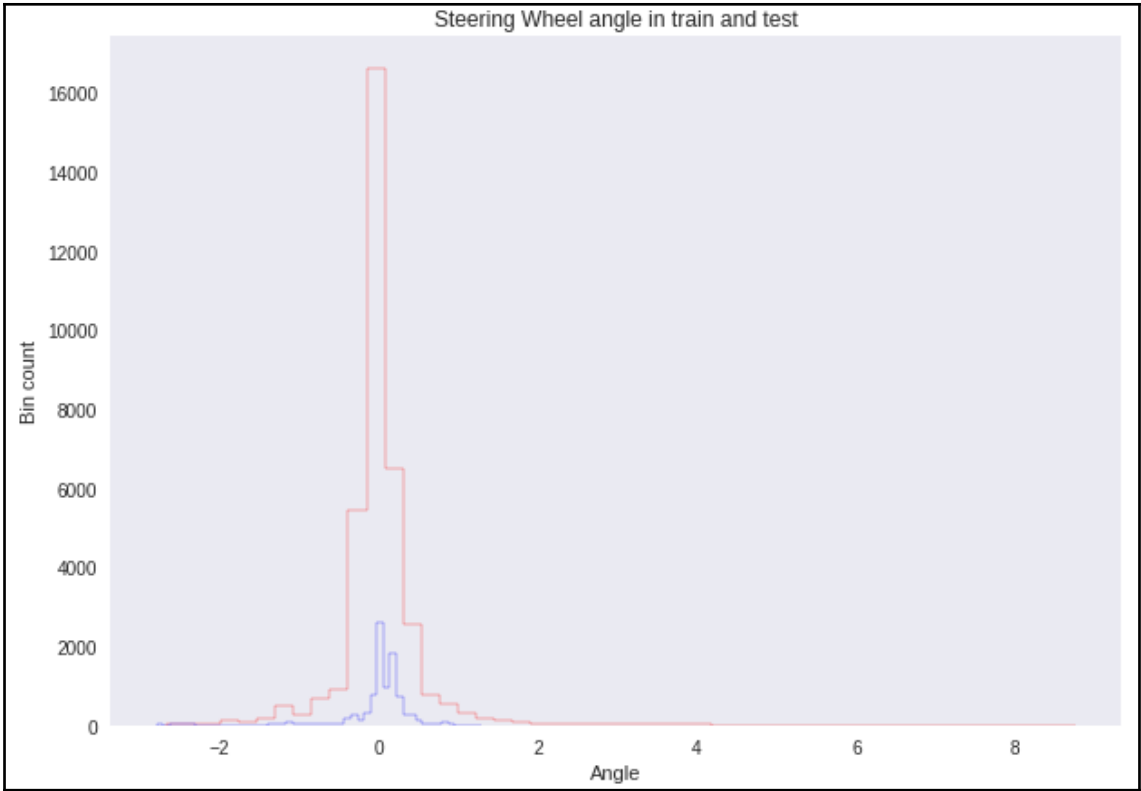

Layer (type)	Output Shape	Param #
flatten_1 (Flatten)	(None, 28672)	0
dense_1 (Dense)	(None, 512)	14680576
dropout_1 (Dropout)	(None, 512)	0
dense_2 (Dense)	(None, 100)	51300
dropout_2 (Dropout)	(None, 100)	0
dense_3 (Dense)	(None, 50)	5050
dropout_3 (Dropout)	(None, 50)	0
dense_4 (Dense)	(None, 10)	510
dense_5 (Dense)	(None, 1)	11
-----		
Total params: 14,737,447		
Trainable params: 14,737,447		
Non-trainable params: 0		



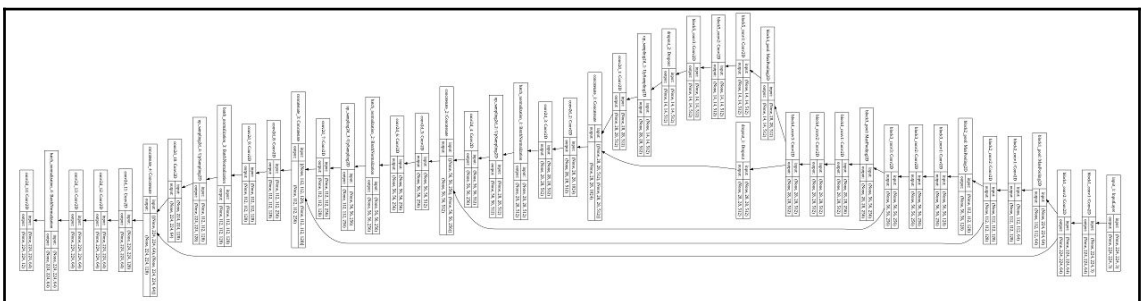
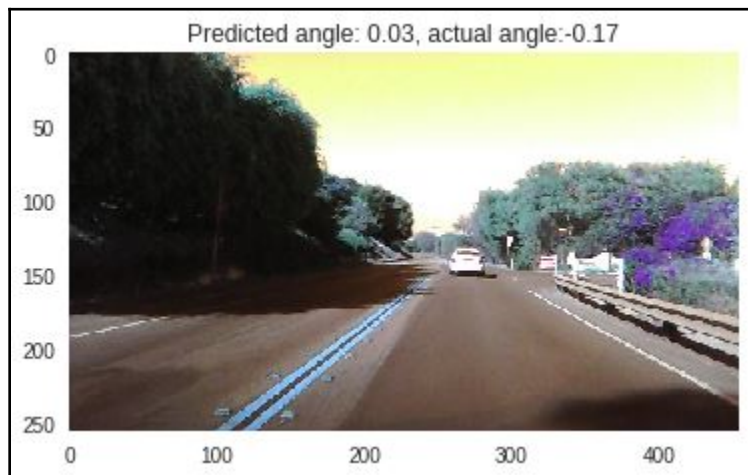
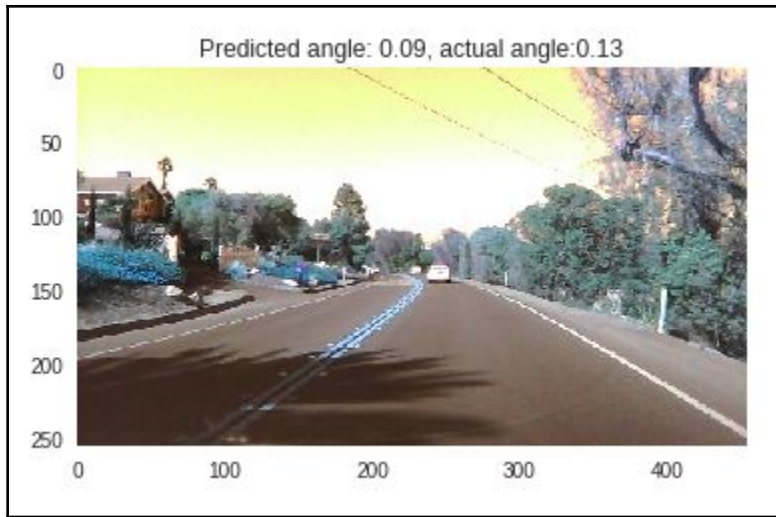



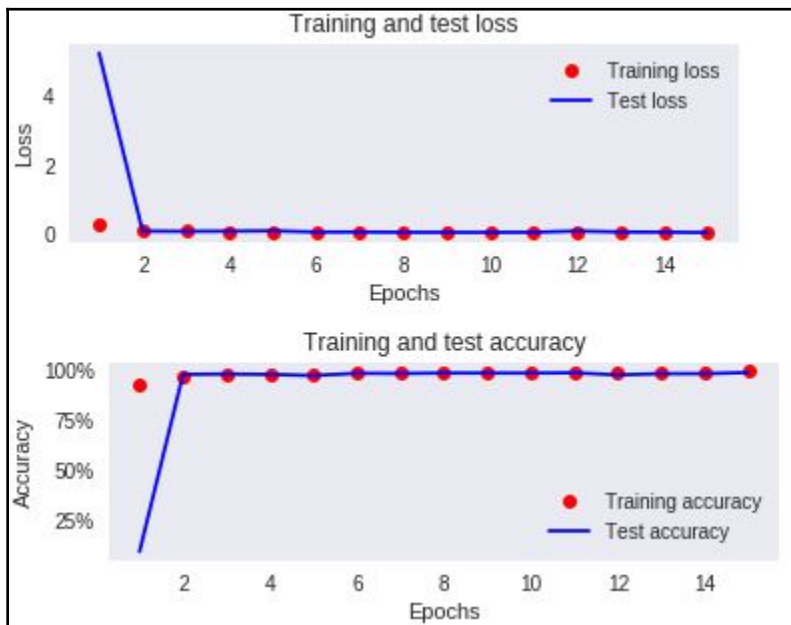
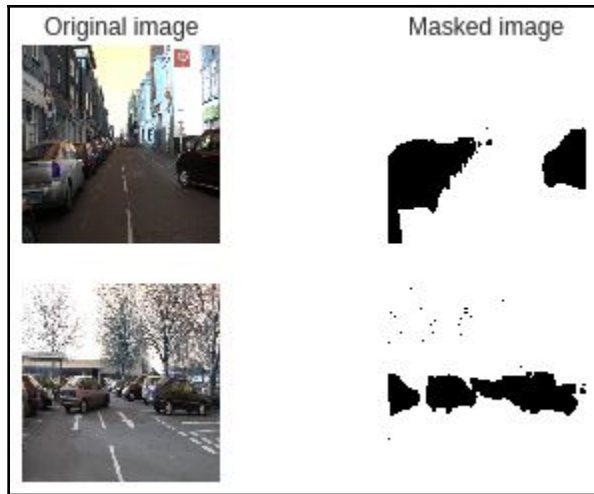

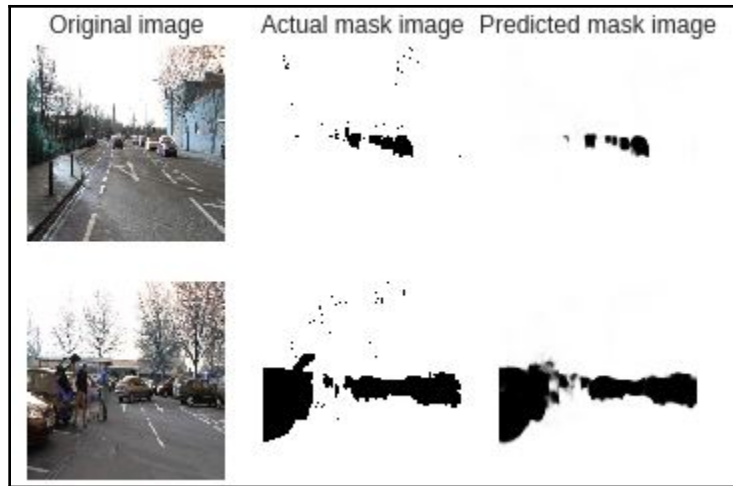



---

## Chapter 8: Image Generation

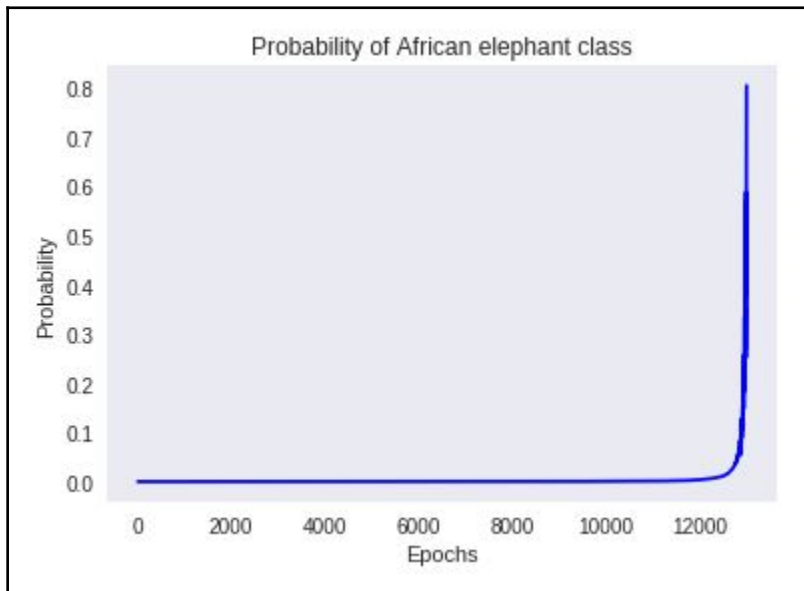

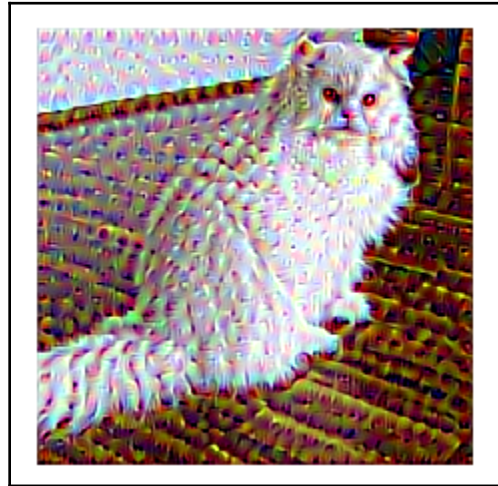





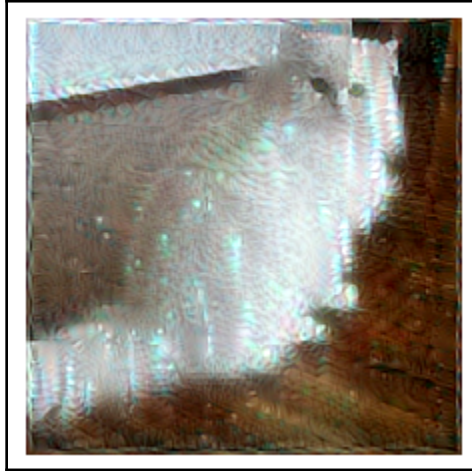

Layer (type)	Output Shape	Param #
dense_1 (Dense)	(None, 256)	25856
leaky_re_lu_1 (LeakyReLU)	(None, 256)	0
batch_normalization_1 (Batch Normalization)	(None, 256)	1024
dense_2 (Dense)	(None, 512)	131584
leaky_re_lu_2 (LeakyReLU)	(None, 512)	0
batch_normalization_2 (Batch Normalization)	(None, 512)	2048
dense_3 (Dense)	(None, 1024)	525312
leaky_re_lu_3 (LeakyReLU)	(None, 1024)	0
batch_normalization_3 (Batch Normalization)	(None, 1024)	4096
dense_4 (Dense)	(None, 784)	803600
reshape_1 (Reshape)	(None, 28, 28, 1)	0
=====		
Total params: 1,493,520		
Trainable params: 1,489,936		
Non-trainable params: 3,584		



Layer (type)	Output Shape	Param #
flatten_1 (Flatten)	(None, 784)	0
dense_5 (Dense)	(None, 784)	615440
leaky_re_lu_4 (LeakyReLU)	(None, 784)	0
dense_6 (Dense)	(None, 392)	307720
leaky_re_lu_5 (LeakyReLU)	(None, 392)	0
dense_7 (Dense)	(None, 1)	393
=====		
Total params: 923,553		
Trainable params: 923,553		
Non-trainable params: 0		

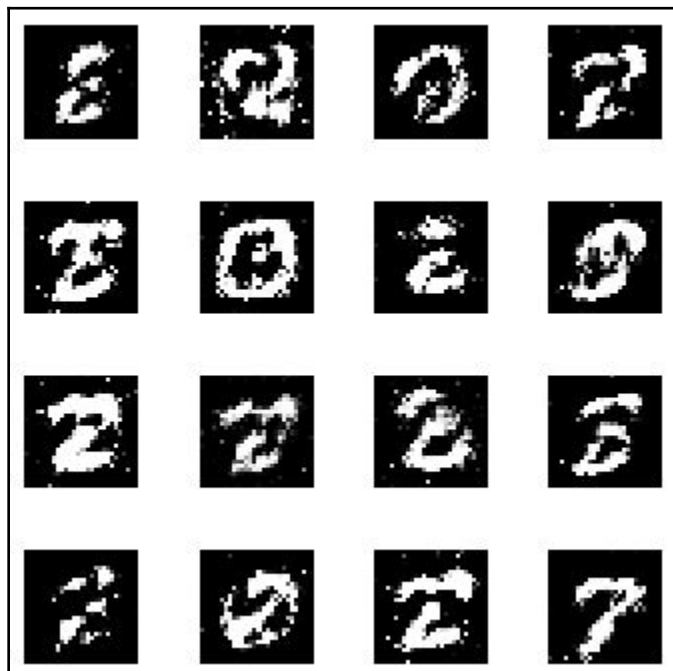

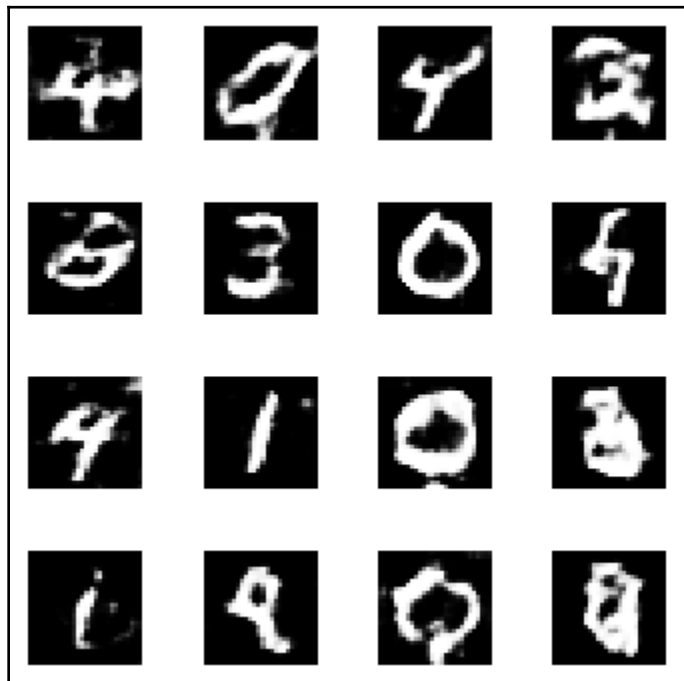
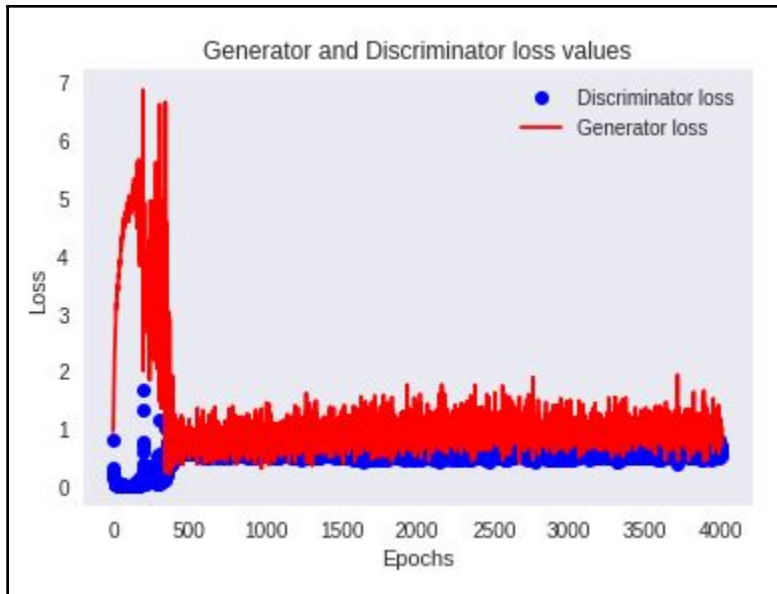

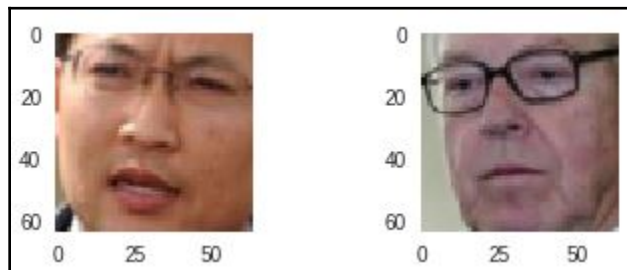
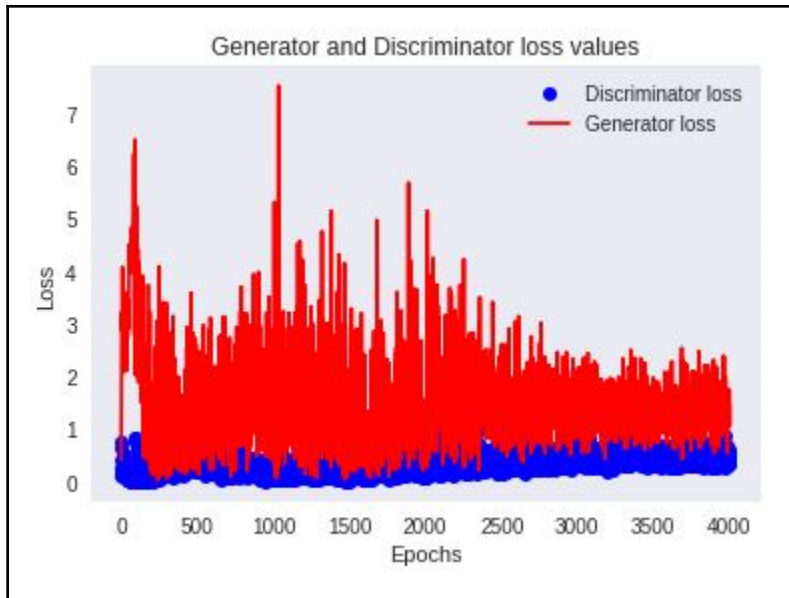

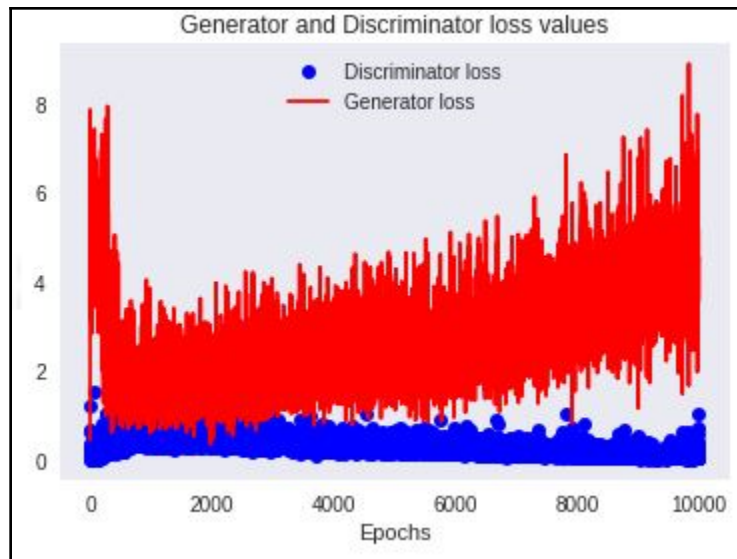





---

## Chapter 9: Encoding Inputs

Input sentences  
I like playing Chess  
I enjoy playing Chess

	I	like	playing	Chess	enjoy
I	1	0	0	0	0
like	0	1	0	0	0
playing	0	0	1	0	0
Chess	0	0	0	1	0
enjoy	0	0	0	0	1

	I	like	playing	Chess	enjoy
I like playing Chess	1	1	1	1	0
I enjoy playing Chess	1	0	1	1	1

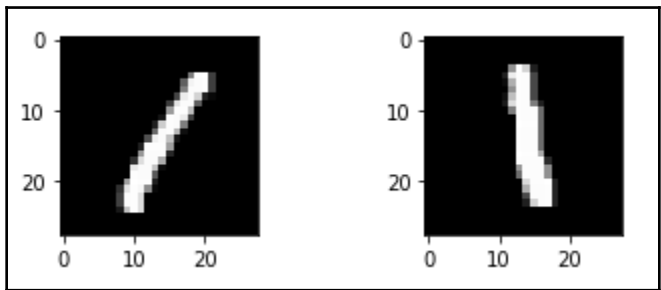

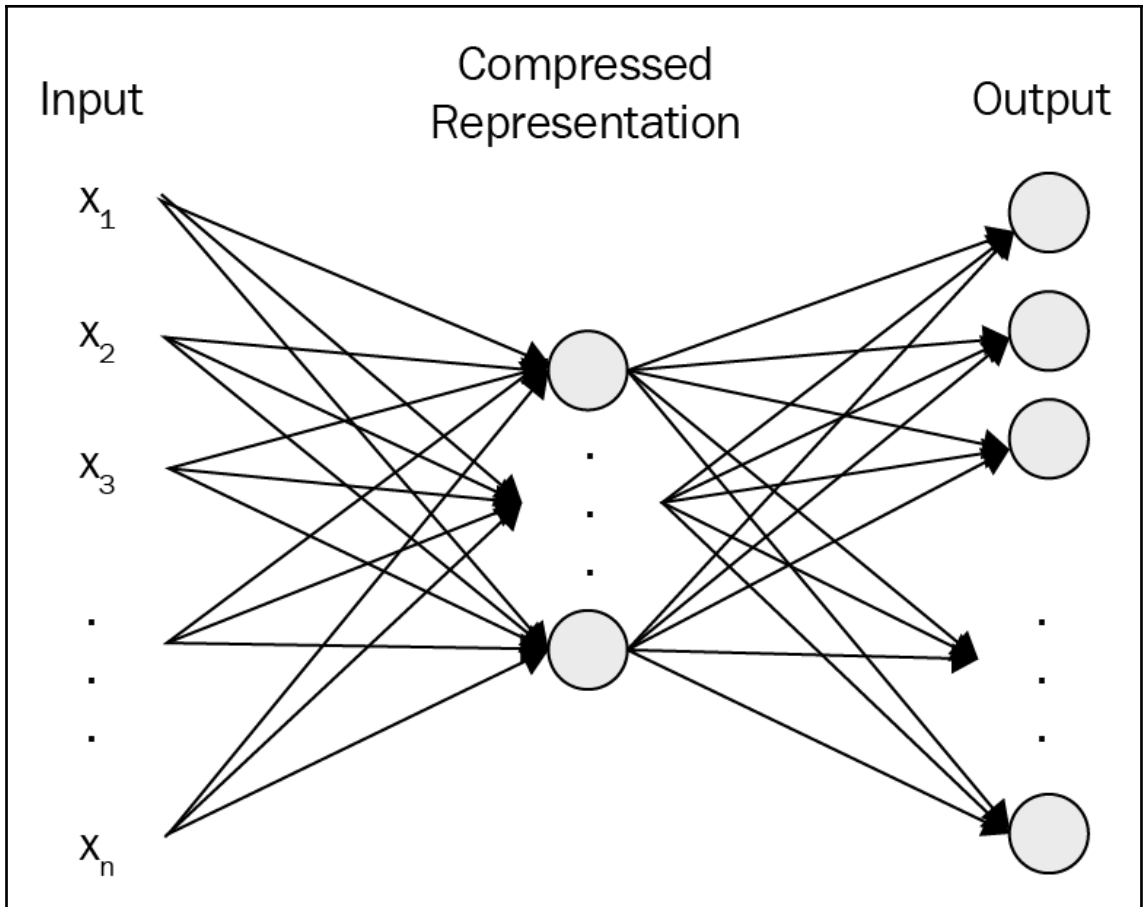

Layer (type)	Output Shape	Param #
dense_1 (Dense)	(None, 32)	25120
dense_2 (Dense)	(None, 784)	25872
Total params: 50,992		
Trainable params: 50,992		
Non-trainable params: 0		



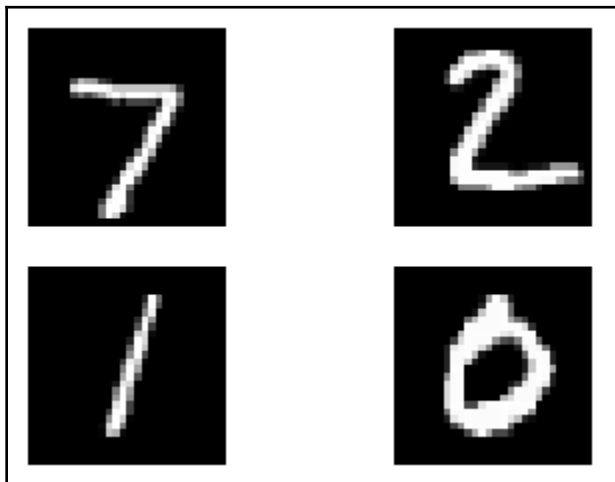

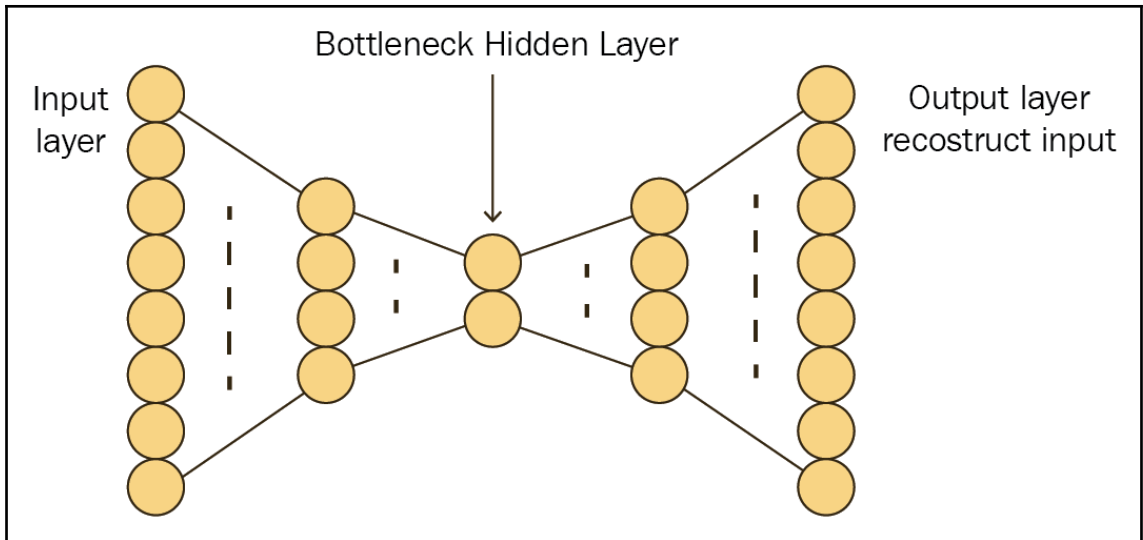

Layer (type)	Output Shape	Param #
dense_18 (Dense)	(None, 100)	78500
dense_19 (Dense)	(None, 32)	3232
dense_20 (Dense)	(None, 100)	3300
dense_21 (Dense)	(None, 784)	79184
=====		
Total params: 164,216		
Trainable params: 164,216		
Non-trainable params: 0		

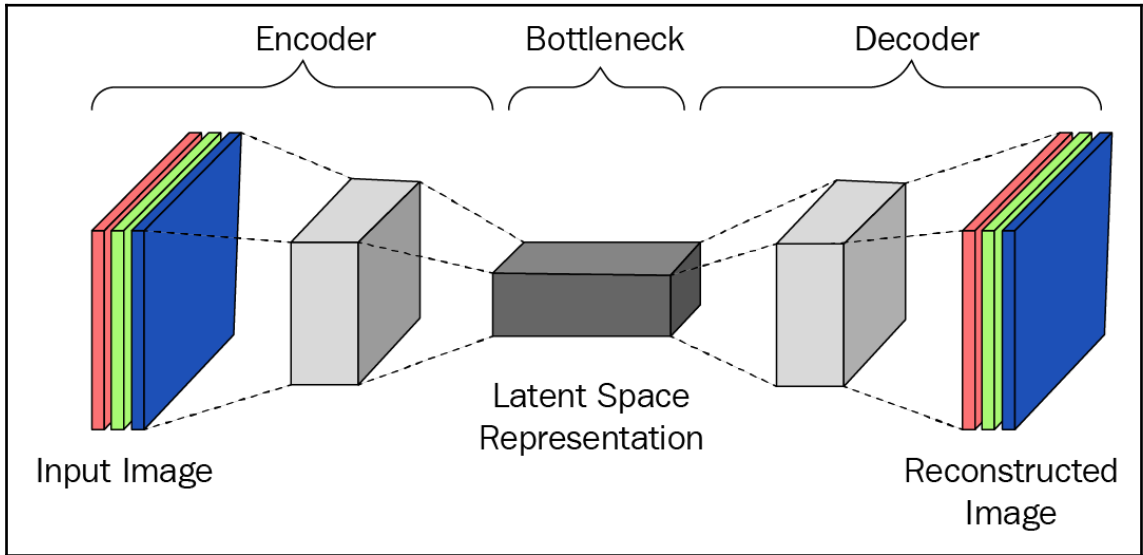
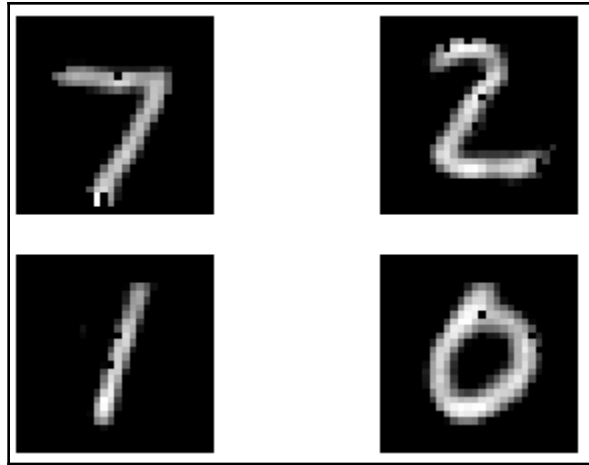

Layer (type)	Output Shape	Param #
conv1 (Conv2D)	(None, 28, 28, 32)	320
pool1 (MaxPooling2D)	(None, 14, 14, 32)	0
conv2 (Conv2D)	(None, 14, 14, 16)	4624
pool2 (MaxPooling2D)	(None, 7, 7, 16)	0
conv3 (Conv2D)	(None, 7, 7, 8)	1160
pool3 (MaxPooling2D)	(None, 3, 3, 8)	0
conv4 (Conv2D)	(None, 3, 3, 32)	2336
pool4 (MaxPooling2D)	(None, 1, 1, 32)	0
flatten (Flatten)	(None, 32)	0
reshape_2 (Reshape)	(None, 1, 1, 32)	0
conv2d_transpose_5 (Conv2DTr	(None, 3, 3, 8)	2312
conv2d_transpose_6 (Conv2DTr	(None, 7, 7, 16)	3216
conv2d_transpose_7 (Conv2DTr	(None, 14, 14, 32)	32800
conv2d_transpose_8 (Conv2DTr	(None, 28, 28, 32)	230432
conv2d_2 (Conv2D)	(None, 28, 28, 1)	289
=====		
Total params: 277,489		
Trainable params: 277,489		
Non-trainable params: 0		

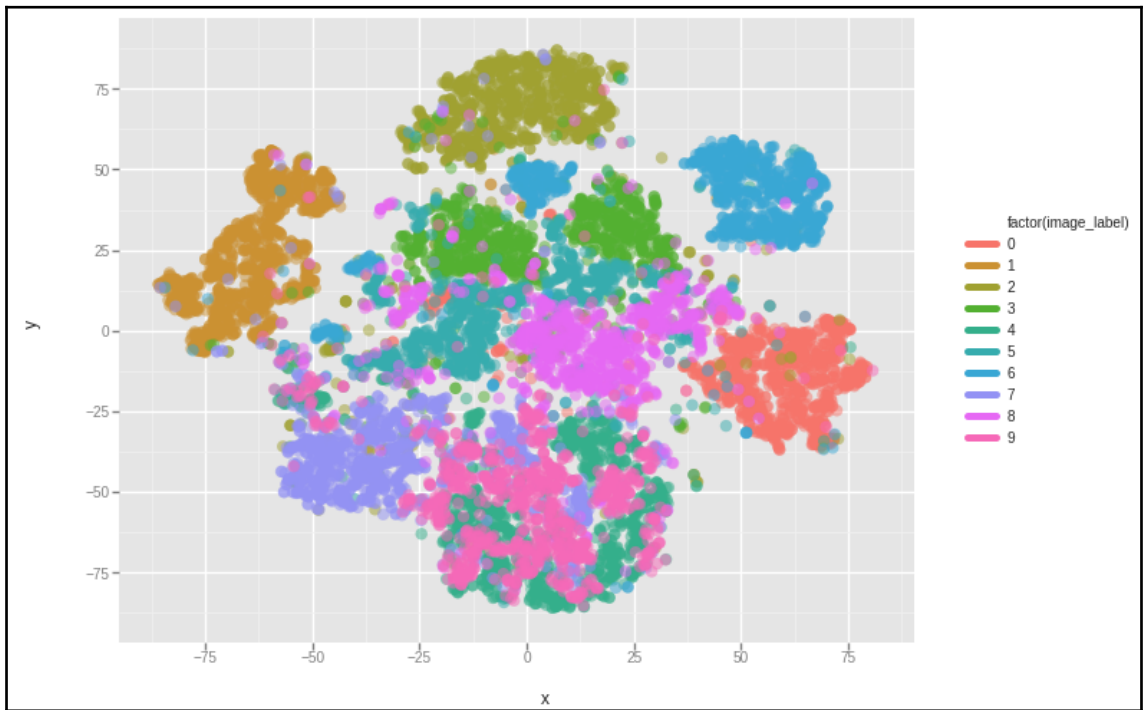
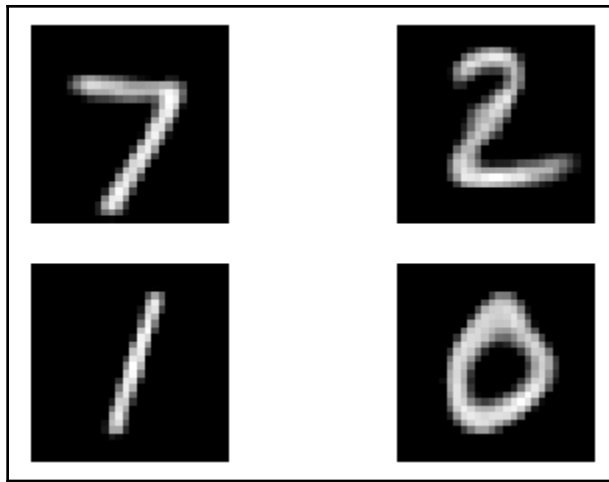

User	Movies	rating	timestamp
1	100	5	1394496000
2	101	3	1395546000
3	100	5	1445578000

Layer (type)	Output Shape	Param #	Connected to
user_in (InputLayer)	(None, 1)	0	
article_in (InputLayer)	(None, 1)	0	
embedding_1 (Embedding)	(None, 1, 100)	94300	user_in[0][0]
embedding_2 (Embedding)	(None, 1, 100)	168200	article_in[0][0]
dot_4 (Dot)	(None, 100, 100)	0	embedding_1[0][0] embedding_2[0][0]
flatten_4 (Flatten)	(None, 10000)	0	dot_4[0][0]
dense_7 (Dense)	(None, 500)	5000500	flatten_4[0][0]
dense_8 (Dense)	(None, 1)	501	dense_7[0][0]
Total params: 5,263,501			
Trainable params: 5,263,501			
Non-trainable params: 0			

# Chapter 10: Text Analysis Using Word Vectors

Input sentences

I enjoy playing TT
I like playing TT

Unique words		One hot encoding				
I	I	1	0	0	0	0
enjoy	enjoy	0	1	0	0	0
playing	playing	0	0	1	0	0
TT	TT	0	0	0	1	0
like	like	0	0	0	0	1

	A	B	C	D	E	F	G
1							
2		Input					Output
3							
4		enjoy	playing	TT			I
5		I	playing	TT			enjoy
6		I	enjoy	TT			playing
7		I	enjoy	playing			TT
8		like	playing	TT			I
9		I	playing	TT			like
10		I	like	TT			playing
11		I	like	playing			TT
12							

	I	J	K	L	M	N	O	P	Q	R	S	T
1	Vectorizing inputs											
2						Output vector						
3												
4	0	1	1	1	0	1	0	0	0	0	0	0
5	1	0	1	1	0	0	1	0	0	0	0	0
6	1	1	0	1	0	0	0	1	0	0	0	0
7	1	1	1	0	0	0	0	0	1	0	0	0
8	0	0	1	1	1	0	0	0	0	0	0	0
9	1	0	1	1	0	0	0	0	0	0	1	0
10	1	0	0	1	1	0	0	1	0	0	0	0
11	1	0	1	0	1	0	0	0	0	1	0	0



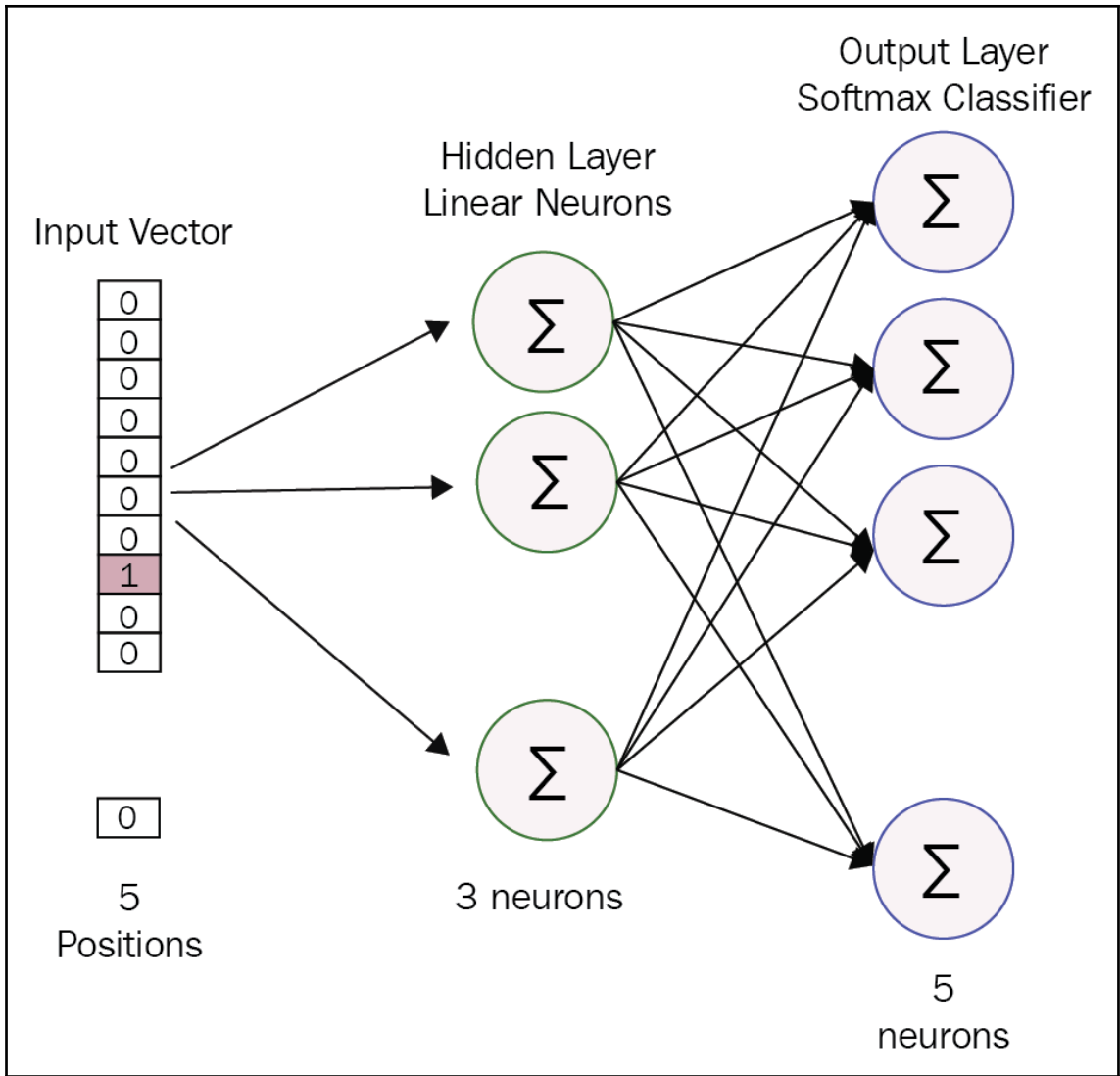

```
{'i': 1, 'enjoy': 0, 'playing': 3, 'tt': 4, 'like': 2}
(2, 5)
[[1 1 0 1 1]
 [0 1 1 1 1]]
```

---

```
['enjoy playing TT',  
'I playing TT',  
'I enjoy TT',  
'I enjoy playing',  
'like playing TT',  
'I playing TT',  
'I like TT',  
'I like playing']
```

```
['I', 'enjoy', 'playing', 'TT', 'I', 'like', 'playing', 'TT']
```

```
array([[1, 0, 0, 1, 1],  
       [0, 1, 0, 1, 1],  
       [1, 1, 0, 0, 1],  
       [1, 1, 0, 1, 0],  
       [0, 0, 1, 1, 1],  
       [0, 1, 0, 1, 1],  
       [0, 1, 1, 0, 1],  
       [0, 1, 1, 1, 0]])
```

```
array([[0, 1, 0, 0, 0],  
       [1, 0, 0, 0, 0],  
       [0, 0, 0, 1, 0],  
       [0, 0, 0, 0, 1],  
       [0, 1, 0, 0, 0],  
       [0, 0, 1, 0, 0],  
       [0, 0, 0, 1, 0],  
       [0, 0, 0, 0, 1]])
```

```
i      [[ 1.6032135  1.3119363 -1.7557099]]  
enjoy  [[-1.4379208 -0.94042814 -2.4946306 ]]  
playing      [[ 0.77564436 -2.887907 -0.4725666 ]]  
tt      [[-2.0346394  0.82441056  0.67760855]]  
like    [[-1.4300524 -0.94189996 -2.6602516 ]]
```

---

	airline_sentiment	text
0	1	@VirginAmerica plus you've added commercials t...
1	0	@VirginAmerica it's really aggressive to blast...
2	0	@VirginAmerica and it's a really big bad thing...
3	0	@VirginAmerica seriously would pay \$30 a fligh...
4	1	@VirginAmerica yes, nearly every time I fly VX...

```
['virginamerica', 'plus', 'added', 'commercials', 'experience', 'tacky']
```

```
[[['virginamerica', 'plus', 'added', 'commercials', 'experience', 'tacky'],  
 ['virginamerica',  
  'really',  
  'aggressive',  
  'blast',  
  'obnoxious',  
  'entertainment',  
  'guests',  
  'faces',  
  'amp',  
  'little',  
  'recourse'],  
 ['virginamerica', 'really', 'big', 'bad', 'thing']]]
```

---

```
array([ 0.3419442 , -0.660853 , -0.8875737 , -0.11866002,  3.848598 ,
       -1.859917 ,  1.2849951 ,  1.5322515 , -0.42655924,  0.74873245,
        0.7576644 ,  0.53542703,  1.6549652 ,  1.4168224 ,  1.4571517 ,
       -1.1921175 , -0.83038306, -1.6139846 ,  0.5910155 ,  3.1234474 ,
        1.9208 , -1.0543962 , -0.7666846 , -1.590045 , -0.1548474 ,
        1.1117342 , -0.4835291 , -1.7931118 , -0.22642556, -2.1773818 ,
        0.38367364, -2.0263271 , -2.9695885 , -0.3920376 , -0.8466245 ,
        0.43550012,  1.7326713 ,  2.0108004 , -0.5395172 , -0.04537094,
        0.76008844,  0.74664325,  0.4459887 ,  1.1571167 ,  2.0812125 ,
       -0.7367794 , -0.72291315, -1.3603346 , -0.13599452,  2.689772 ,
       -2.524463 ,  0.5480051 ,  1.689171 ,  0.044644 , -0.27298477,
        1.5061239 , -1.0514534 , -0.02589583,  1.5114399 ,  0.4221726 ,
       -0.9640717 , -1.3412739 , -0.19521172, -1.8486487 ,  0.04619067,
       -0.8271076 , -0.7997853 , -1.3049688 ,  2.0880153 , -0.9300234 ,
        1.1623387 , -0.09183449, -1.8364261 , -0.5820482 ,  1.1316198 ,
       -0.3580541 ,  1.2225895 , -0.85193574, -1.0722245 , -0.7914595 ,
       -1.0597026 ,  0.48279345,  0.7167691 ,  1.4192754 ,  1.9140383 ,
       -1.6390625 , -2.2567384 ,  0.3889435 ,  2.1803992 ,  1.7071763 ,
        0.54344946, -0.50497335,  0.30110064, -0.12276804, -0.34828255,
       -1.041366 , -0.6226012 ,  2.1155527 , -0.7881018 , -0.902104 ]
```

```
(('year', 0.4818694591522217),
 ('week', 0.4710841774940491),
 ('months', 0.35927000641822815),
 ('weeks', 0.35357385873794556),
 ('leg', 0.33413201570510864),
 ('days', 0.3019614517688751),
 ('miles', 0.28956449031829834),
 ('lt', 0.2536947727203369),
 ('pm', 0.25144699215888977),
 ('traveling', 0.2485567033290863])
```

---

```
[('traveling', 0.9996585249900818),
 ('im', 0.9996532201766968),
 ('kids', 0.9996105432510376),
 ('happened', 0.9995968341827393),
 ('plus', 0.9995967745780945),
 ('computer', 0.999592661857605),
 ('list', 0.9995923638343811),
 ('support', 0.9995867609977722),
 ('something', 0.9995864629745483),
 ('extremely', 0.9995763301849365)]
```

```
[(u'week', 0.8365199565887451),
 (u'year', 0.7653313875198364),
 (u'months', 0.681006133556366),
 (u'weeks', 0.65276038646698),
 (u'August', 0.6166313290596008),
 (u'February', 0.6136031746864319),
 (u'October', 0.6114892363548279),
 (u'January', 0.6091349124908447),
 (u'day', 0.600459098815918),
 (u'September', 0.5990685224533081)]
```

```
[(u'queen', 0.7118192911148071)]
```

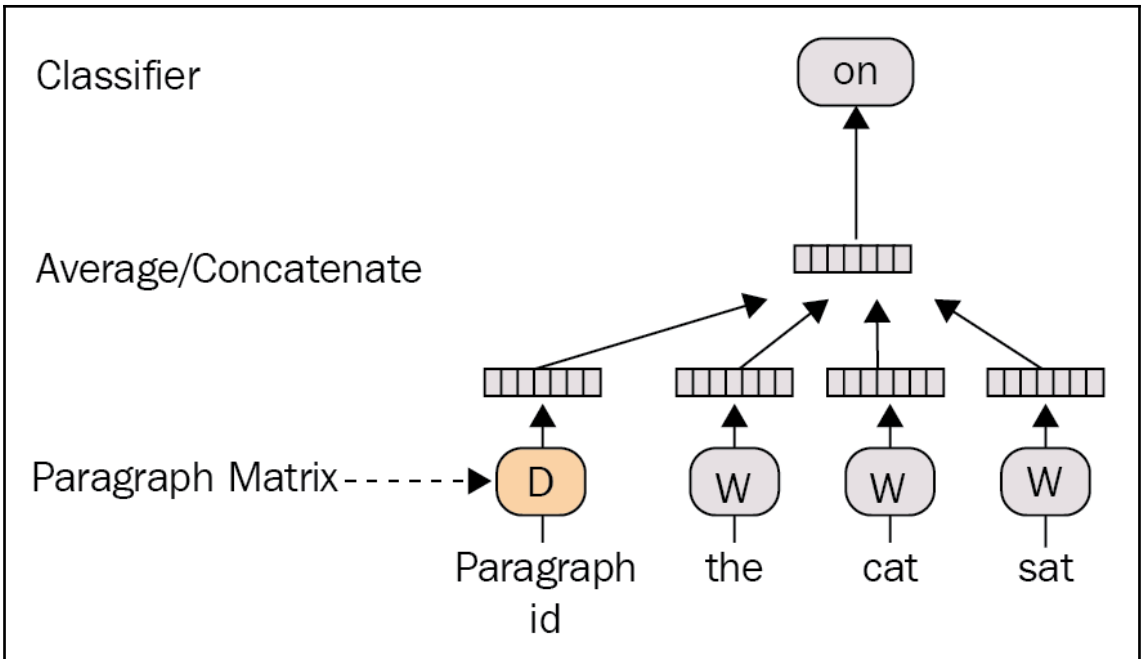

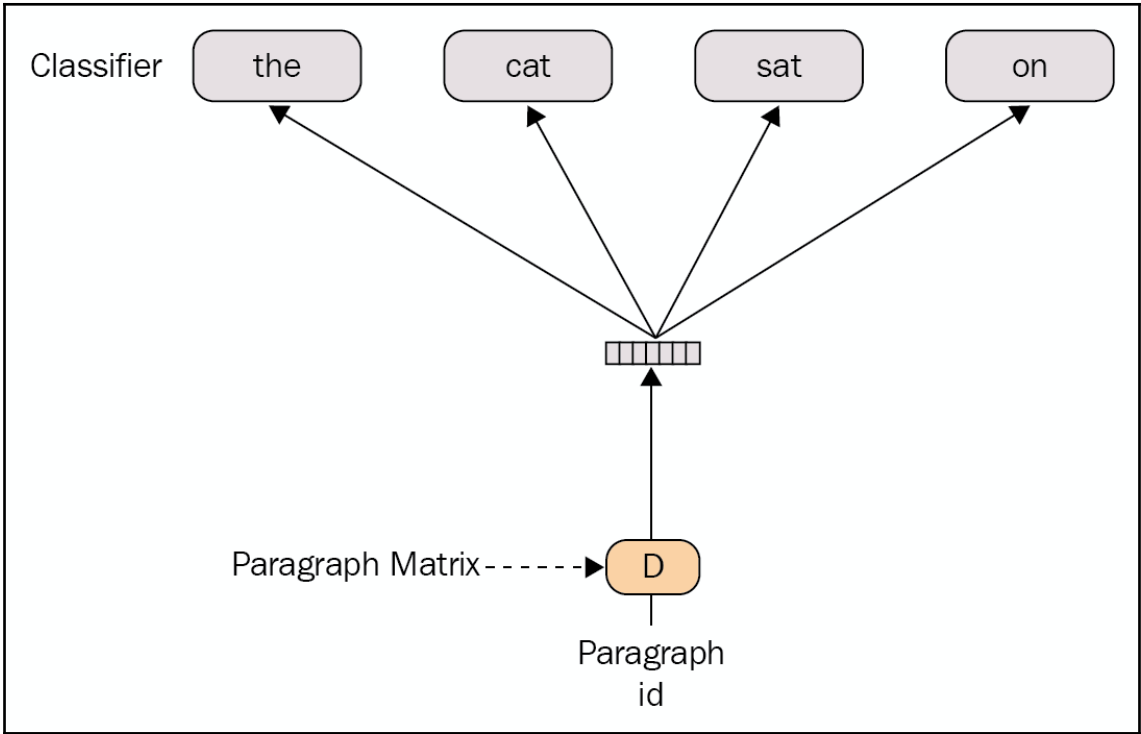

```
[TaggedDocument(words=['virginamerica', 'plus', 'added', 'commercials', 'experience', 'tacky'], tags=['0']),
 TaggedDocument(words=['virginamerica', 'really', 'aggressive', 'blast', 'obnoxious', 'entertainment', 'guests', 'faces', 'amp', 'little', 'recourse'], tags=['1']),
 TaggedDocument(words=['virginamerica', 'really', 'big', 'bad', 'thing'], tags=['2'])]
```

```
[('827', 0.9669191837310791), ('5076', 0.951378583908081), ('2394', 0.9232662916183472)]
```

'united thanks just sent'

'united sent thanks'

	this	is	test	also	a
this	0	2	1	1	1
is	0	0	1	1	1
test	0	0	0	0	0
also	0	0	0	0	1
a	0	0	0	0	0

	E	F	G	H	I	J	K	L	M	N
1										
2	Word	this	is	test	also	a	Weights		bias	
3	this	0	2	0.5	0.5	0	0.0574	-0.1704	-0.0123	-0.284
4	is	0	0	1	1	0.5	0.2074	-0.1981	-0.0494	0.109
5	test	0	0	0	0	0	0.0261	0.0927	-0.1035	-0.194
6	also	0	0	0	0	1	-0.2131	0.0088	0.0483	-0.054
7	a	0	0	0	0	0	-0.281	0.1941	-0.0807	-0.223
8										
9										
10	The weightage function	loss value	Weighted loss value							
11	=(G3/100)^(0.75)	=SUMPRODUCT(K3:M3,K4:M4)+N3+N4-LOG(G3))^2	=F11^2*E11							
12	=(H3/100)^0.75	=SUMPRODUCT(K3:M3,K5:M5)+N3+N5-LOG(H3))^2	=F12^2*E12							
13	=(I3/100)^0.75	=SUMPRODUCT(K3:M3,K6:M6)+N3+N6-LOG(I3))^2	=F13^2*E13							
14	=(J4/100)^0.75	=SUMPRODUCT(K4:M4,K5:M5)+N4+N5-LOG(H4))^2	=F14^2*E14							
15	=(I4/100)^0.75	=SUMPRODUCT(K4:M4,K6:M6)+N4+N6-LOG(I4))^2	=F15^2*E15							
16	=(J4/100)^0.75	=SUMPRODUCT(K4:M4,K7:M7)+N4+N7-LOG(J4))^2	=F16^2*E16							
17	=(J6/100)^0.75	=SUMPRODUCT(K6:M6,K7:M7)+N6+N7-LOG(J6))^2	=F17^2*E17							
18		Overall weighted loss value	=SUM(G11:G17)							

```
{'xaizw2ism1': 4425,
'twetpxuppn': 11367,
'cussed': 10939,
'h44uj63cjpg': 6394,
'vn3jjia53o': 6795,
'yellow': 9424,
'four': 350,
'jparkermastin': 6641,
'hsv': 11104,
```

```
matrix([[0. , 1. , 0.75, ..., 0. , 0. , 0. ],
[0. , 0. , 1. , ..., 0. , 0. , 0. ],
[0. , 0. , 0. , ..., 0. , 0. , 0. ],
...,
[0. , 0. , 0. , ..., 0. , 0. , 0. ],
[0. , 0. , 0. , ..., 0. , 0. , 0. ],
[0. , 0. , 0. , ..., 0. , 0. , 0. ]])
```



---

```
[('usairways', 0.9319100099683549),
 ('southwestair', 0.9165424743315992),
 ('americanair', 0.9123728213792929),
 ('jetblue', 0.900383830727353)]
```

Layer (type)	Output Shape	Param #
dense_20 (Dense)	(None, 1000)	101000
dense_21 (Dense)	(None, 1)	1001
activation_10 (Activation)	(None, 1)	0

=====  
Total params: 102,001  
Trainable params: 102,001  
Non-trainable params: 0  
=====

```
array([[2644, 125],
       [ 209, 485]])
```

---

# Chapter 11: Building a Recurrent Neural Network

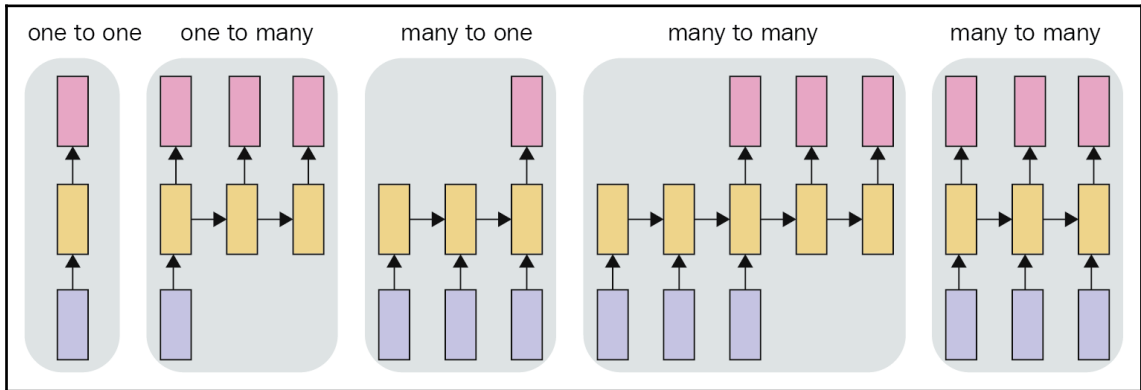

---

many to one

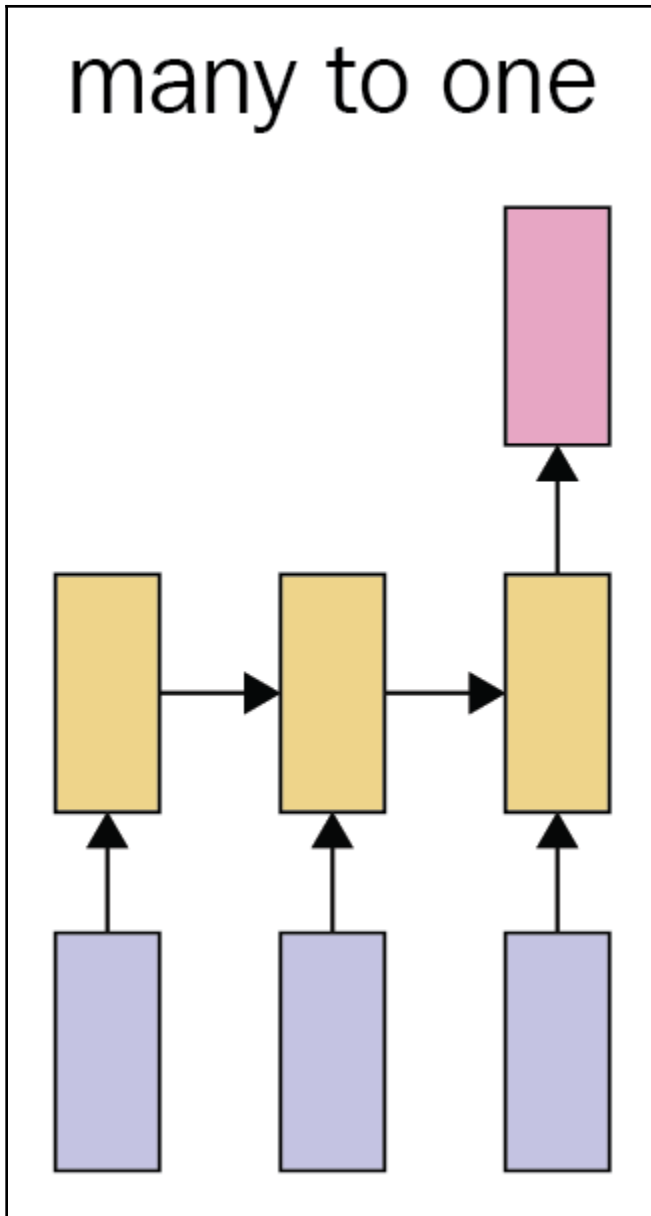

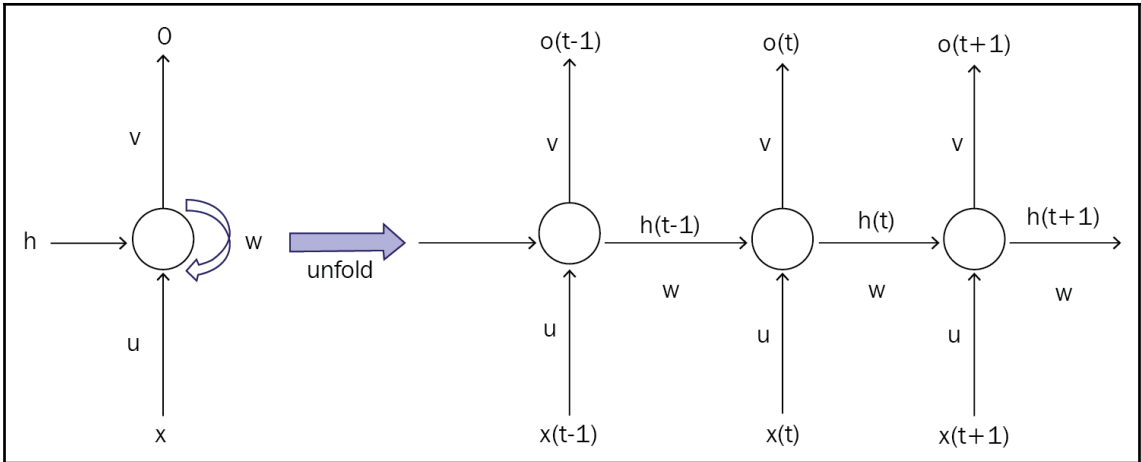

Layer (type)	Output Shape	Param #
simple_rnn_3 (SimpleRNN)	(None, 1)	3
dense_3 (Dense)	(None, 5)	10
Total params: 13		
Trainable params: 13		
Non-trainable params: 0		
None		

```
['united',
'flight',
'usairways',
'americanair',
'southwestair',
'jetblue',
'get',
'cancelled',
'thanks',
'service']
```

---

```
{1: 'united',
 2: 'flight',
 3: 'usairways',
 4: 'americanair',
 5: 'southwestair',
 6: 'jetblue',
```

```
('Original text:', 'virginamerica plus added commercials experience tacky')
('Mapped text:', [44, 459, 1198, 2482, 100, 9958])
```

Layer (type)	Output Shape	Param #
embedding_16 (Embedding)	(None, 26, 32)	401056
simple_rnn_12 (SimpleRNN)	(None, 40)	2920
dense_11 (Dense)	(None, 2)	82
Total params: 404,058		
Trainable params: 404,058		
Non-trainable params: 0		

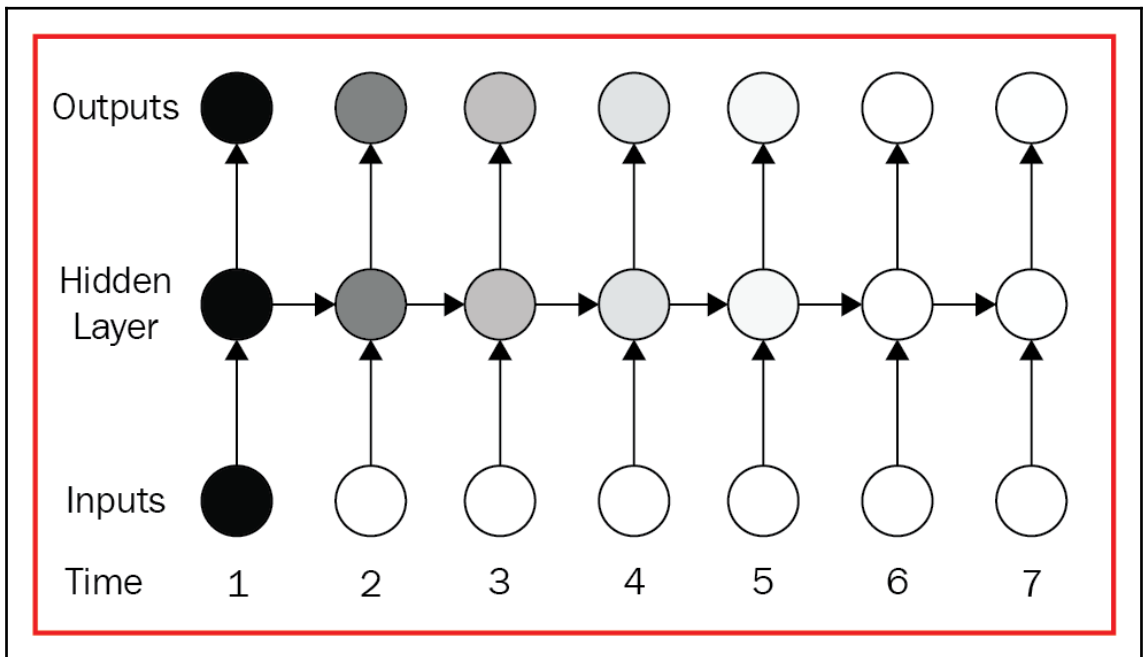
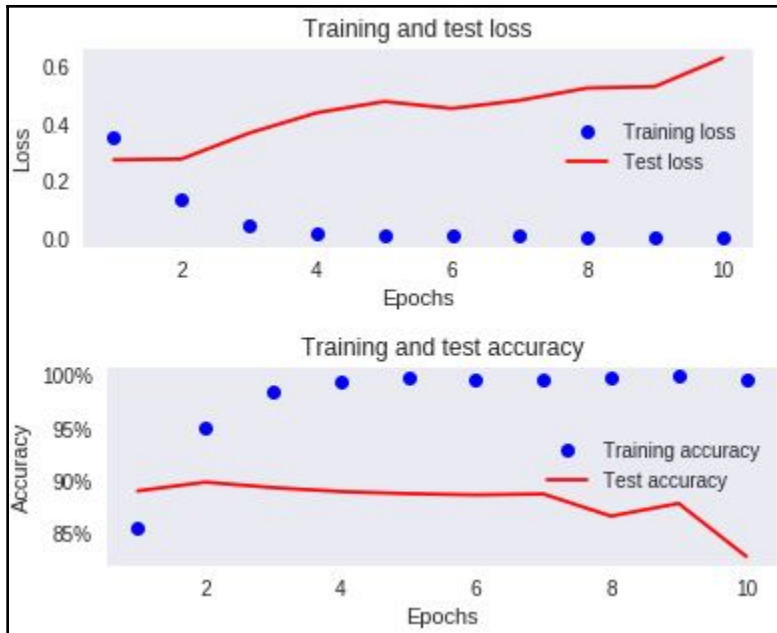

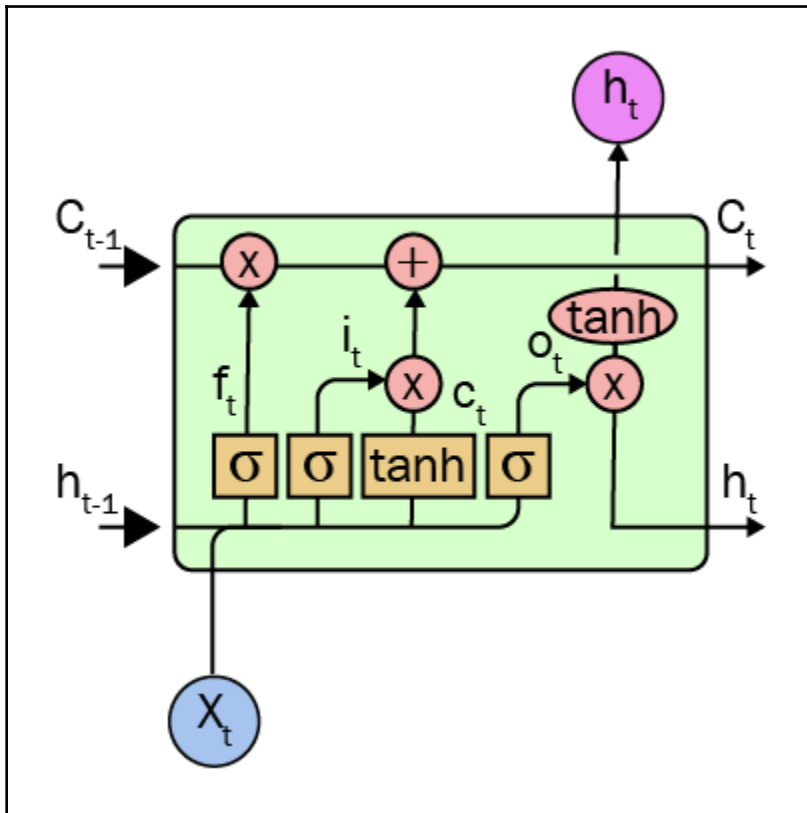
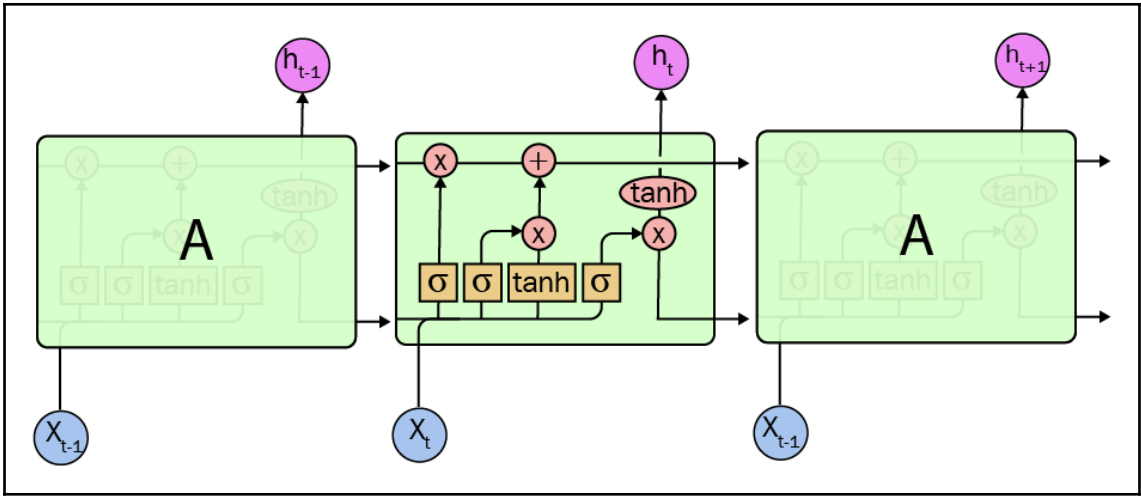

Layer (type)	Output Shape	Param #
lstm_19 (LSTM)	(None, 1)	12
dense_18 (Dense)	(None, 5)	10
Total params: 22		
Trainable params: 22		
Non-trainable params: 0		

Layer (type)	Output Shape	Param #
embedding_20 (Embedding)	(None, 26, 32)	401056
lstm_1 (LSTM)	(None, 40)	11680
dense_14 (Dense)	(None, 2)	82
Total params: 412,818		
Trainable params: 412,818		
Non-trainable params: 0		





Layer (type)	Output Shape	Param #
embedding_21 (Embedding)	(None, 26, 32)	401056
lstm_2 (LSTM)	(None, 26, 40)	11680
lstm_3 (LSTM)	(None, 40)	12960
dense_15 (Dense)	(None, 2)	82
=====		
Total params: 425,778		
Trainable params: 425,778		
Non-trainable params: 0		

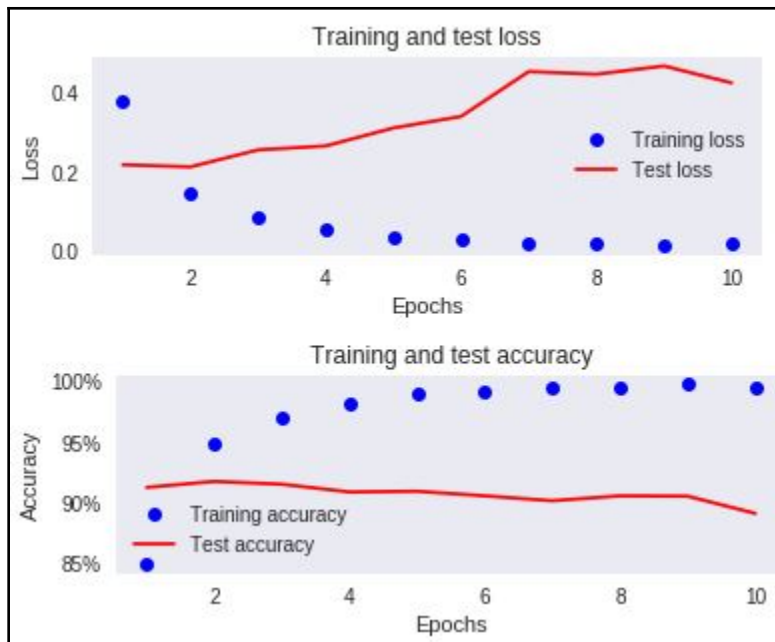

---

# Chapter 12: Applications of a Many-to-One Architecture RNN

'her sister on the bank, and of having nothing to'

```
input words list:
['alice', 'was', 'beginning', 'to', 'get', 'very', 'tired', 'of', 'sitting', 'by']
label(output) words list:
her
```

```
Shape of X: (30407, 10, 3028)
Shape of y: (30407, 3028)
```

Layer (type)	Output Shape	Param #
lstm_2 (LSTM)	(None, 128)	1616384
dense_2 (Dense)	(None, 3028)	390612
Total params: 2,006,996		
Trainable params: 2,006,996		
Non-trainable params: 0		

```
Iteration #: 0
Train on 27366 samples, validate on 3041 samples
Epoch 1/1
27366/27366 [=====] - 33s 1ms/step - loss: 6.2146 - val_loss: 8.2937
Generating from seed: ['not', 'met', 'the', 'solicitation', 'requirements', 'we', 'know', 'of', 'no', 'prohibition']
the the the the the the the the the the the the the the the the the the the the the the the the the
```

```
Iteration #: 49
Train on 27366 samples, validate on 3041 samples
Epoch 1/1
27366/27366 [=====] - 35s 1ms/step - loss: 0.0066 - val_loss: 14.0219
Generating from seed: ['by', 'all', 'the', 'terms', 'of', 'this', 'agreement', 'you', 'must', 'cease']
like all all they they re from him at the march hare said the queen the words rabbit dropped the dormouse
```

```

Iteration #: 48
Train on 27366 samples, validate on 3041 samples
Epoch 1/1
27366/27366 [=====] - 58s 2ms/step - loss: 0.0422 - val_loss: 13.5398
Generating from seed: ['to', 'meet', 'and', 'keep', 'up', 'with', 'these', 'requirements', 'we', 'do']
with some time you were the hatter said was in a low voice which only taught us said the duchess and are

```

User	Movies	rating	timestamp
1	100	5	1394496000
2	101	3	1395546000
3	100	5	1445578000

Layer (type)	Output Shape	Param #
embedding_1 (Embedding)	(None, 5, 32)	46304
lstm_1 (LSTM)	(None, 100)	53200
dense_1 (Dense)	(None, 1000)	101000
dense_2 (Dense)	(None, 1447)	1448447
=====		
Total params: 1,648,951		
Trainable params: 1,648,951		
Non-trainable params: 0		

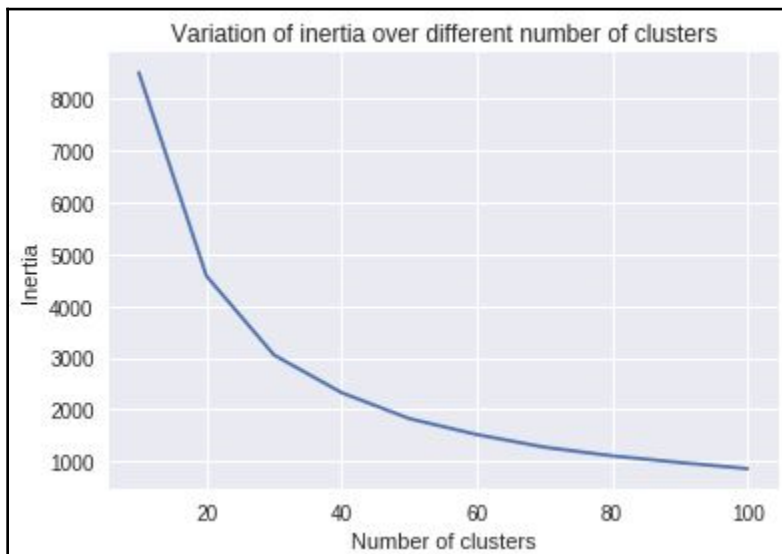
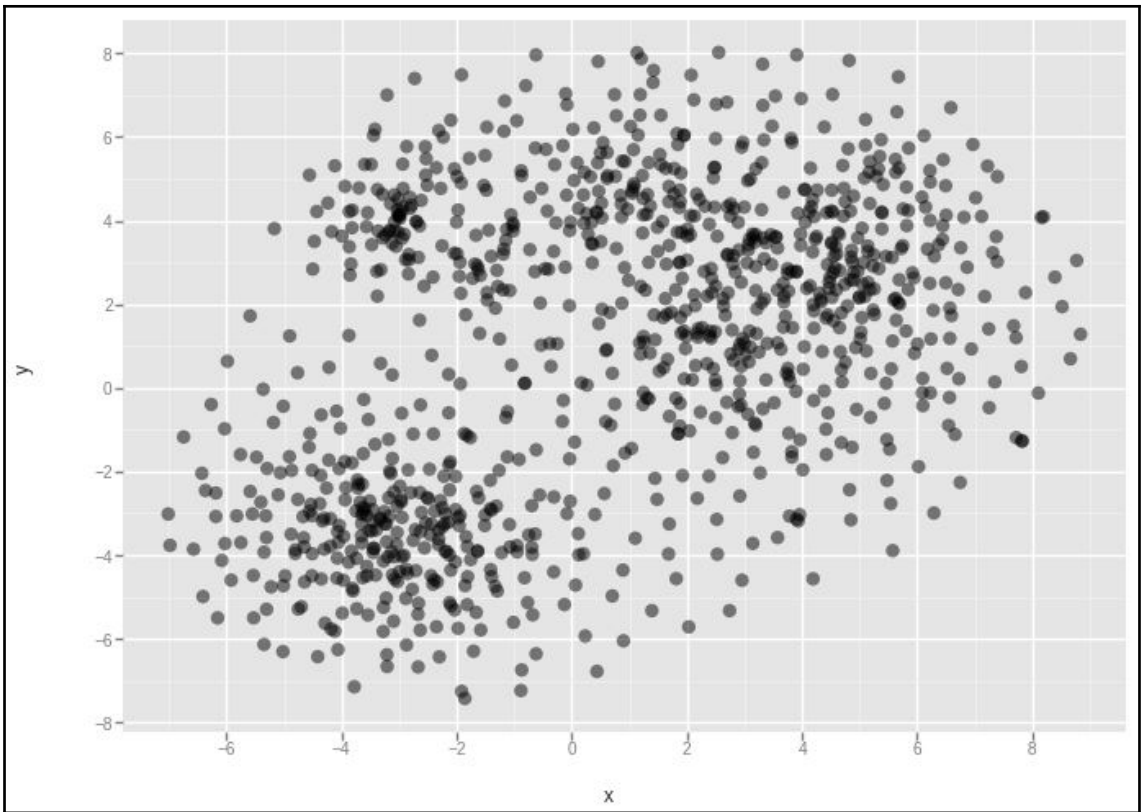

Layer (type)	Output Shape	Param #
dense_1 (Dense)	(None, 5, 100)	200
lstm_1 (LSTM)	(None, 100)	80400
dense_2 (Dense)	(None, 1000)	101000
dense_3 (Dense)	(None, 1)	1001
Total params: 182,601		
Trainable params: 182,601		
Non-trainable params: 0		

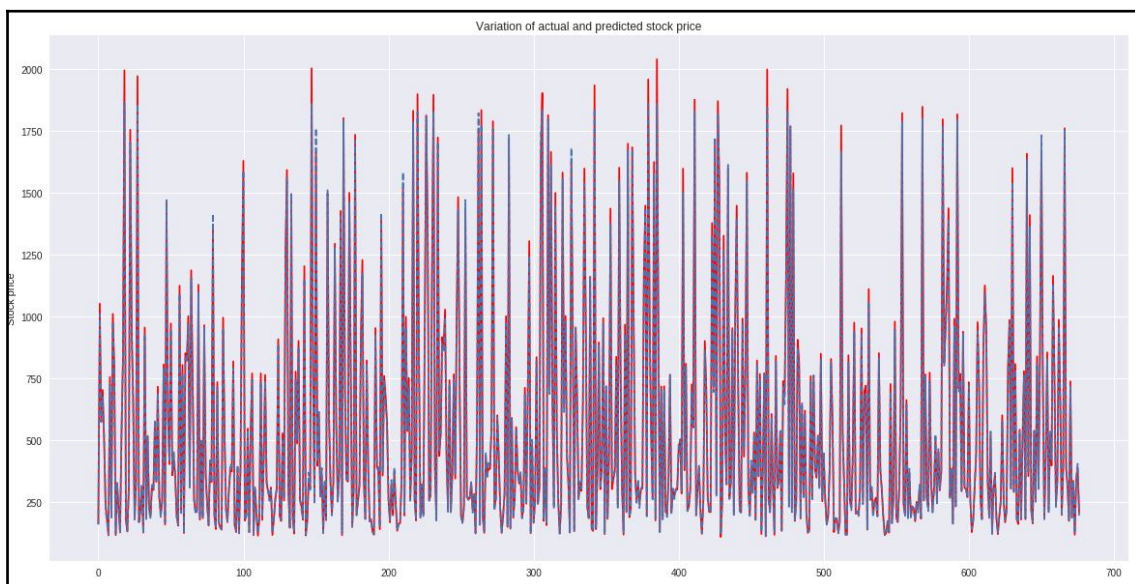

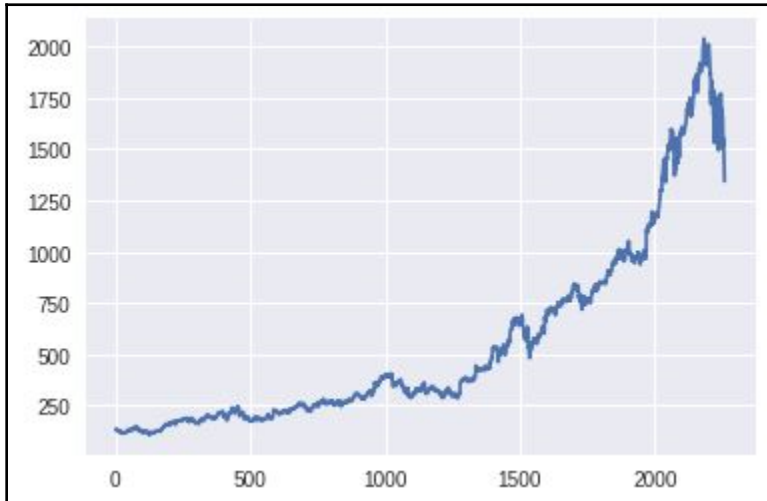
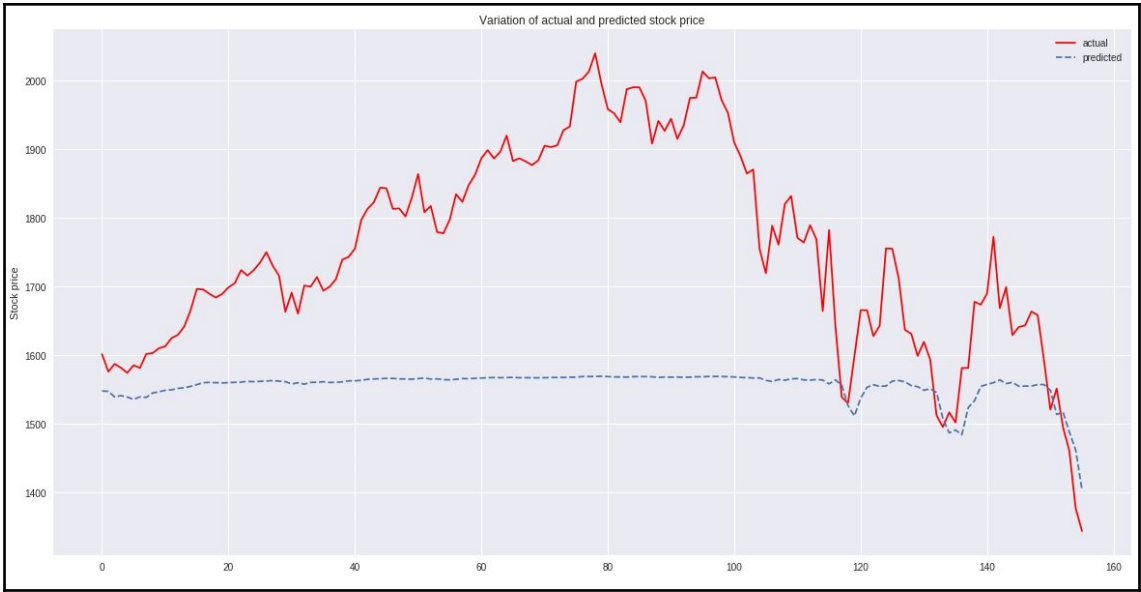

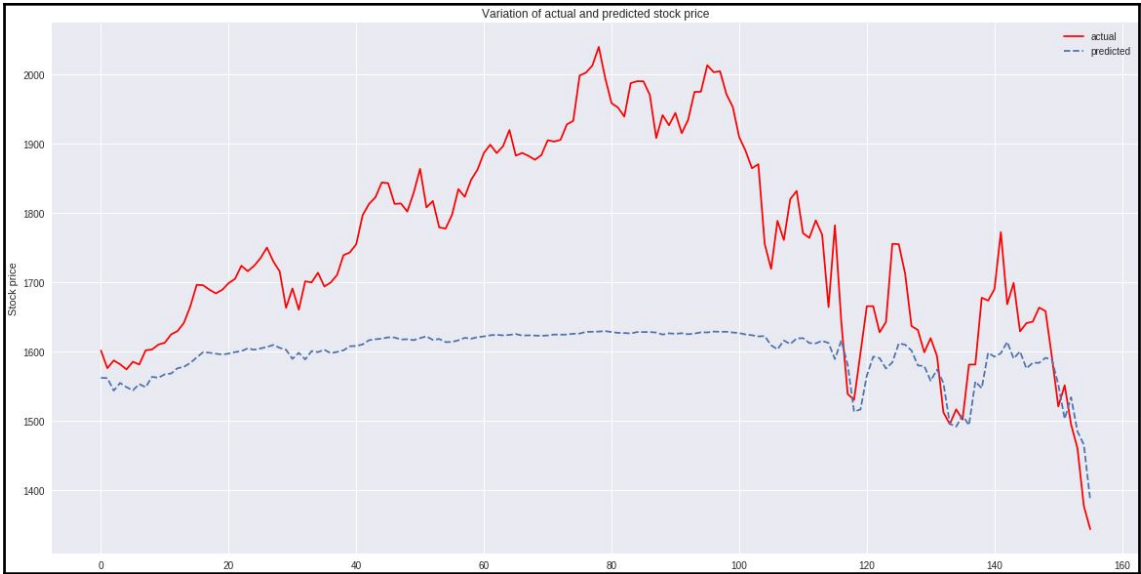



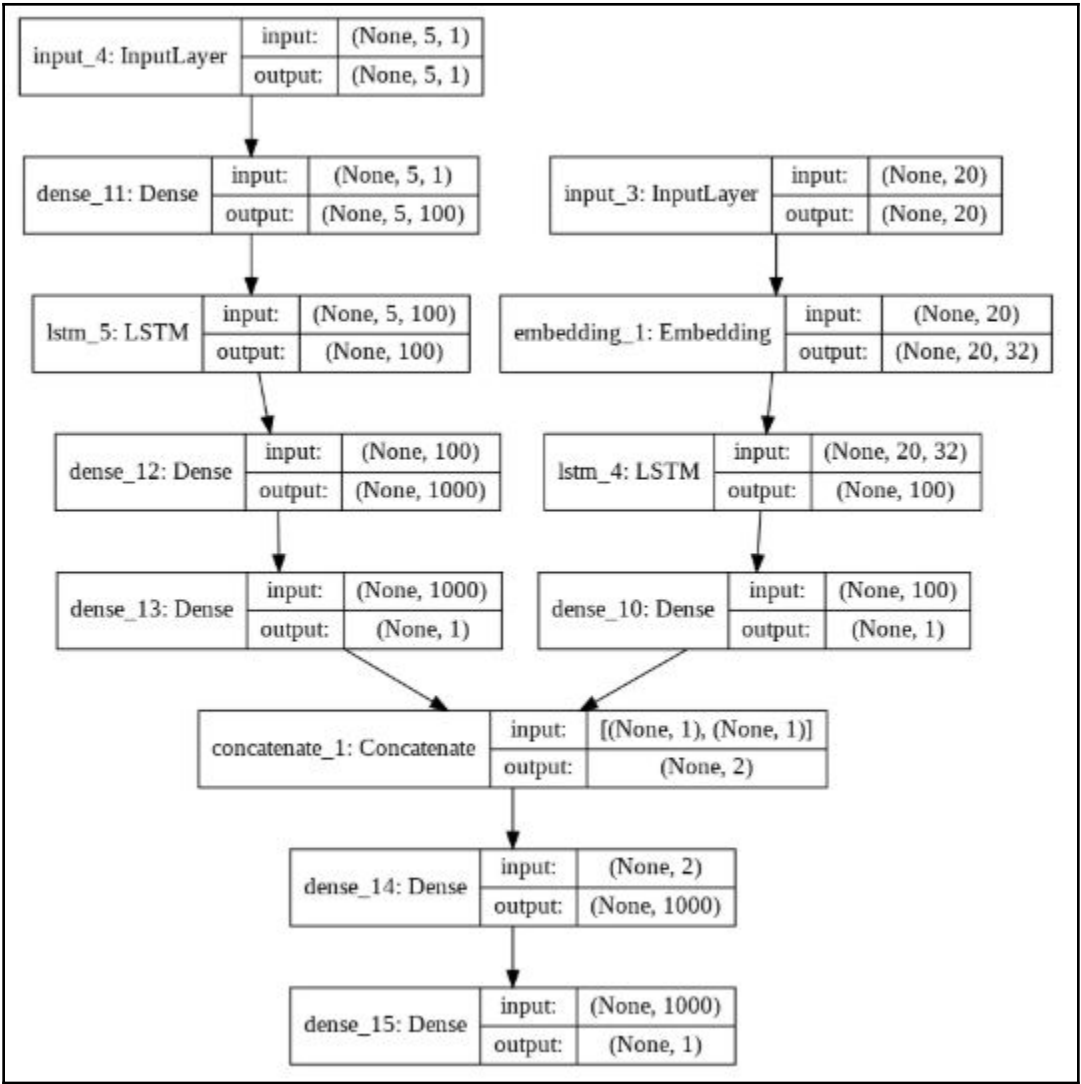

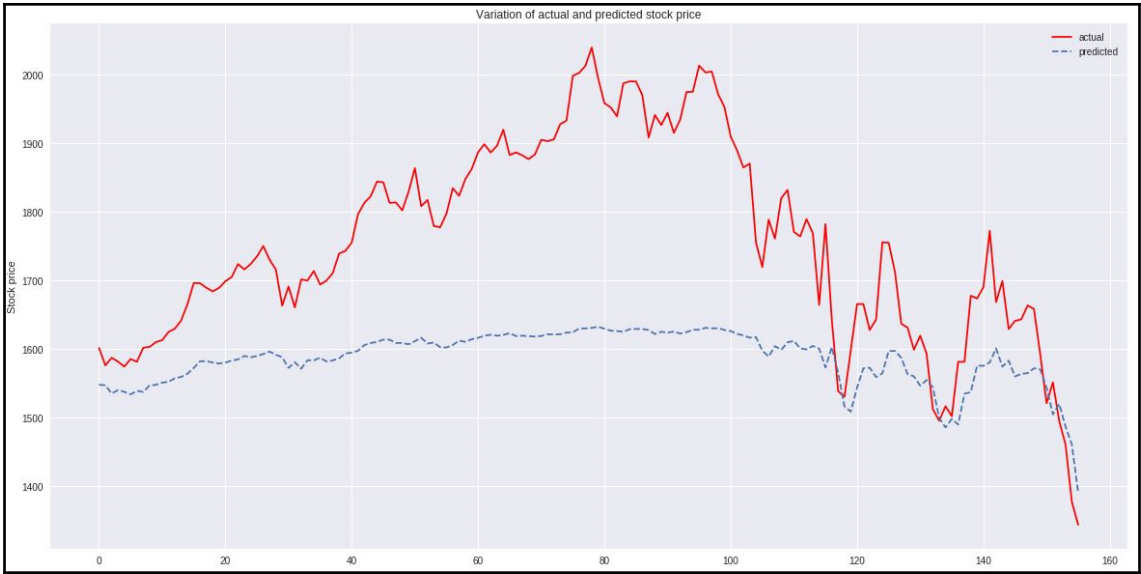

# Chapter 13: Sequence-to-Sequence Learning

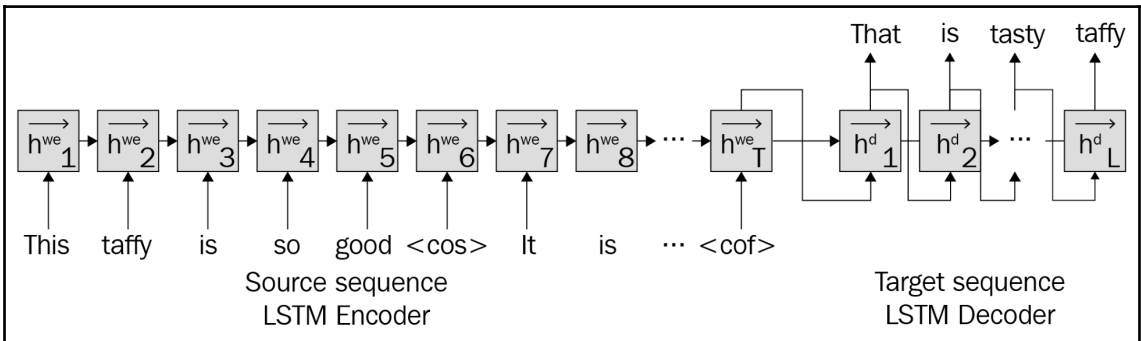
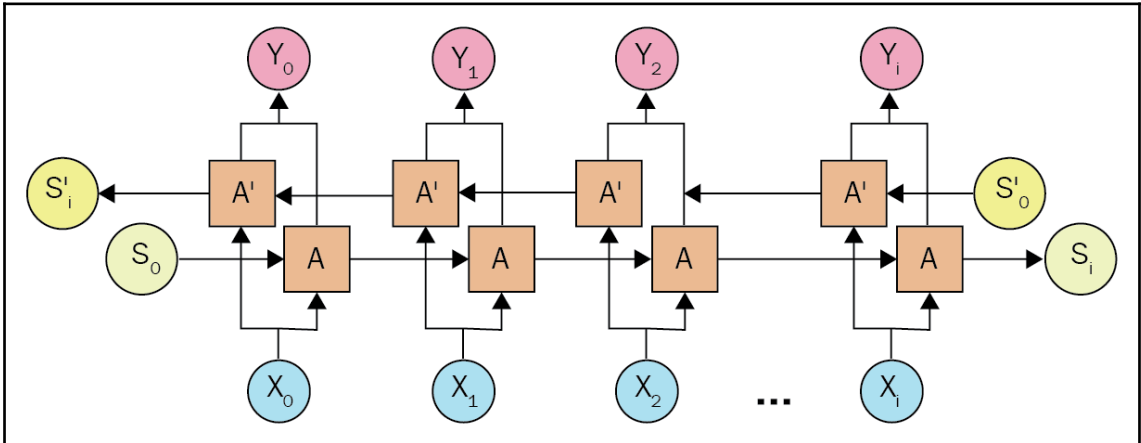

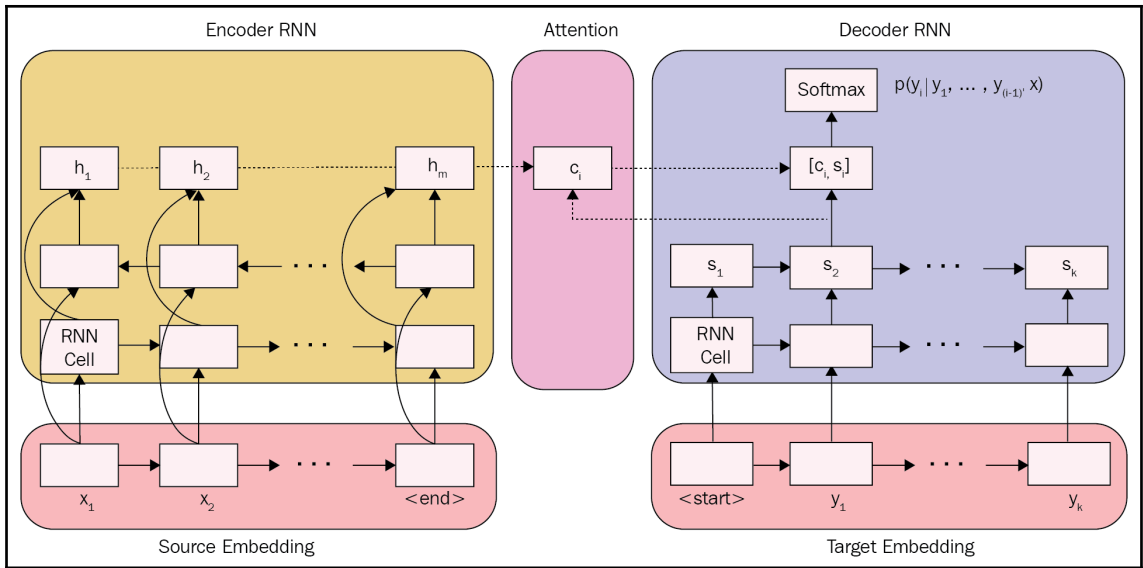

Layer (type)	Output Shape	Param #
input_9 (InputLayer)	(None, 2, 1)	0
lstm_9 (LSTM)	(None, 1)	12
dense_8 (Dense)	(None, 2)	4
=====		
Total params: 16		
Trainable params: 16		
Non-trainable params: 0		

Layer (type)	Output Shape	Param #
input_2 (InputLayer)	(None, 2, 1)	0
lstm_2 (LSTM)	(None, 2, 1)	12
dense_2 (Dense)	(None, 2, 1)	2
=====		
Total params: 14		
Trainable params: 14		
Non-trainable params: 0		

```

Done loading: /content/atis.train.pkl
  samples: 4978
  vocab_size: 943
  slot count: 129
  intent count: 26
Done loading: /content/atis.test.pkl
  samples: 893
  vocab_size: 943
  slot count: 129
  intent count: 26

```

Token	Entity	Intent
'air': 195,	'B-aircraft_code': 0,	'abbreviation': 0,
'aircraft': 196,	'B-airline_code': 1,	'aircraft': 1,
'airfare': 197,	'B-airline_name': 2,	'aircraft+flight+flight_no': 2,
'airfares': 198,	'B-airport_code': 3,	'airfare': 3,
'airline': 199,	'B-airport_name': 4,	'airfare+flight': 4,

```

query[0].
array([178, 479, 902, 851, 431, 444, 266, 240,
       351, 240, 27, 482, 827, 606, 179])

slots[0].
array([128, 128, 128, 128, 128, 128, 48, 128,
       78, 128, 14, 128, 128, 12, 128])

intent[0].
array([14])

```

```

0: flight: BOS i want to fly from boston at 838 am and arrive in denver at 1110 in the morning EOS
intent: flight

```

BOS	0
i	0
want	0
to	0
fly	0
from	0
boston	B-fromloc.city_name
at	0
838	B-depart_time.time
am	I-depart_time.time
and	0
arrive	0
in	0
denver	B-toloc.city_name
at	0
1110	B-arrive_time.time
in	0
the	0
morning	B-arrive_time.period_of_day
EOS	0

```

print(i2t2[0])
print(i2s2[0])
print(i2in2[0]).

```

```

['BOS', 'i', 'want', 'to', 'fly', 'from', 'boston', 'at', '
['0', '0', '0', '0', '0', '0', 'B-fromloc.city_name', '0',
flight

```

```
print('tokens: ',i2t2[0])
print('slots: ',i2s2[0])
print('intent: ',i2in2[0])
```

```
tokens: ['BOS', 'i', 'want', 'to', 'fly', 'from', 'boston',
slots: ['O', 'O', 'O', 'O', 'O', 'O', 'B-fromloc.city_name',
intent: flight
```

Layer (type)	Output Shape	Param #
input_1 (InputLayer)	(None, 50)	0
embedding_1 (Embedding)	(None, 50, 32)	28512
dropout_1 (Dropout)	(None, 50, 32)	0
bidirectional_1 (Bidirection	(None, 50, 200)	106400
time_distributed_1 (TimeDist	(None, 50, 124)	24924
=====		
Total params: 159,836		
Trainable params: 159,836		
Non-trainable params: 0		

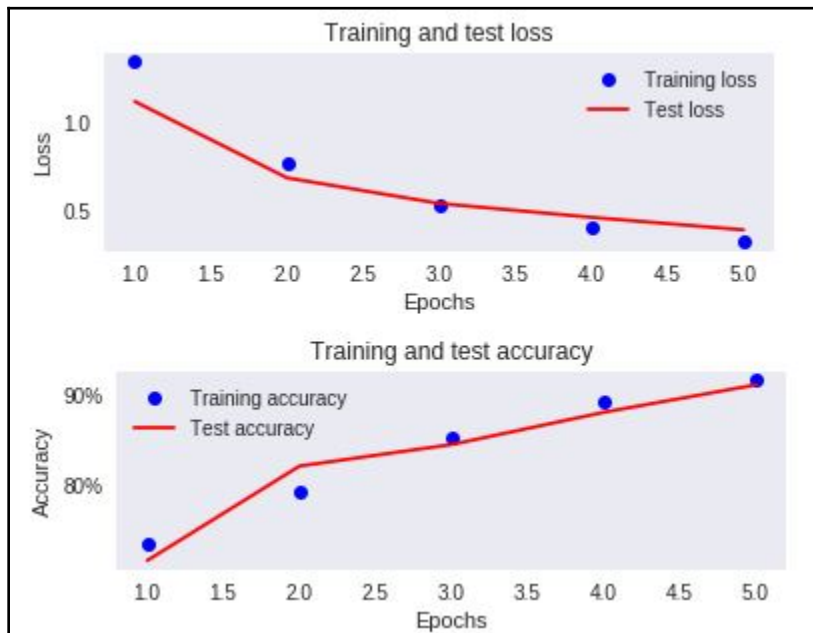



---

```
[[ 1., 14., 41., 40., 4., 11., 3., 23., 2., 0., 0., 0., 0.,  
 0., 0., 0., 0., 0., 0., 0., 0., 0., 0., 0., 0.,  
 0., 0., 0., 0., 0., 0., 0., 0., 0., 0., 0., 0.,  
 0., 0., 0., 0., 0., 0., 0., 0., 0., 0., 0.]])
```

```
intent_int_to_word[pred_index_intent[0]]  
  
'flight'
```

```
word: boston entity: B-fromloc.city_name  
word: dallas entity: B-toloc.city_name
```

	eng	fr
0	go	start va end
1	run	start cours end
2	run	start courez end
3	wow	start ça alors end
4	fire	start au feu end

```
'he is unk good '
```

Layer (type)	Output Shape	Param #
embedding_8 (Embedding)	(None, 17, 128)	49408
bidirectional_6 (Bidirection	(None, 17, 512)	788480
lstm_14 (LSTM)	(None, 17, 256)	787456
dense_8 (Dense)	(None, 17, 359)	92263
-----		
Total params: 1,717,607		
Trainable params: 1,717,607		
Non-trainable params: 0		



Layer (type)	Output Shape	Param #
embedding_9 (Embedding)	(None, 8, 128)	49408
bidirectional_7 (Bidirection	(None, 512)	788480
repeat_vector_2 (RepeatVecto	(None, 17, 512)	0
lstm_16 (LSTM)	(None, 17, 256)	787456
time_distributed_2 (TimeDist	(None, 17, 359)	92263
=====		
Total params: 1,717,607		
Trainable params: 1,717,607		
Non-trainable params: 0		

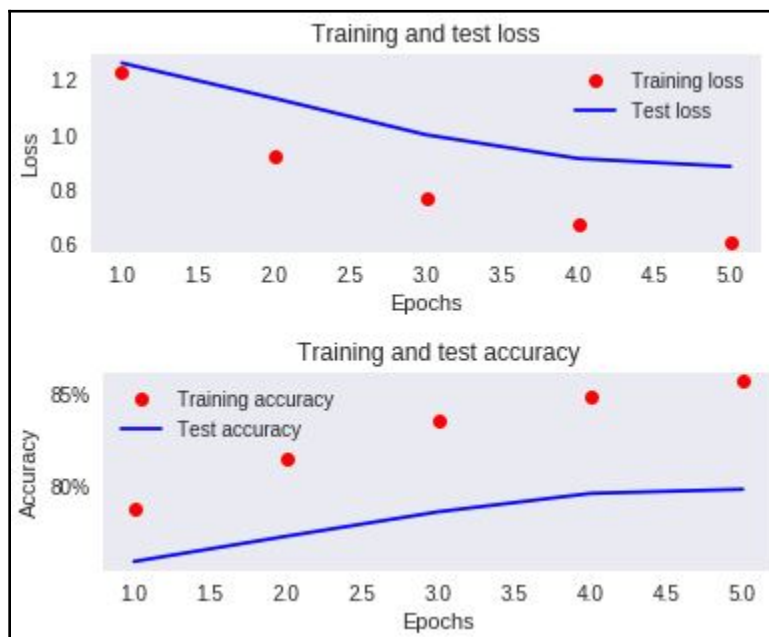

Layer (type)	Output Shape	Param #	Connected to
input_3 (InputLayer)	(None, None)	0	
input_4 (InputLayer)	(None, None)	0	
embedding_10 (Embedding)	(None, None, 128)	49408	input_3[0][0]
embedding_11 (Embedding)	(None, None, 128)	45952	input_4[0][0]
lstm_17 (LSTM)	[(None, 256), (None, 394240		embedding_10[0][0]
lstm_18 (LSTM)	[(None, None, 256), 394240		embedding_11[0][0] lstm_17[0][1] lstm_17[0][2]
dense_10 (Dense)	(None, None, 2000)	514000	lstm_18[0][0]
dense_11 (Dense)	(None, None, 359)	718359	dense_10[0][0]
Total params: 2,116,199			
Trainable params: 2,116,199			
Non-trainable params: 0			

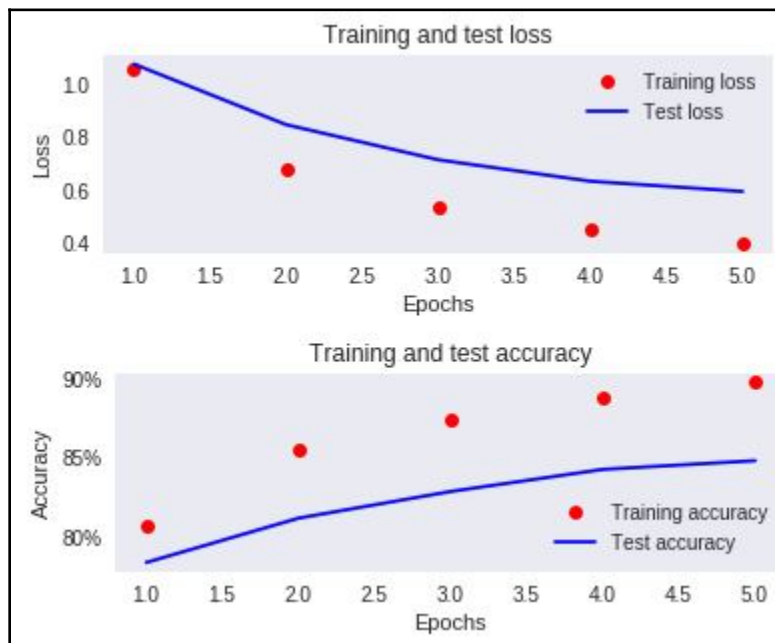

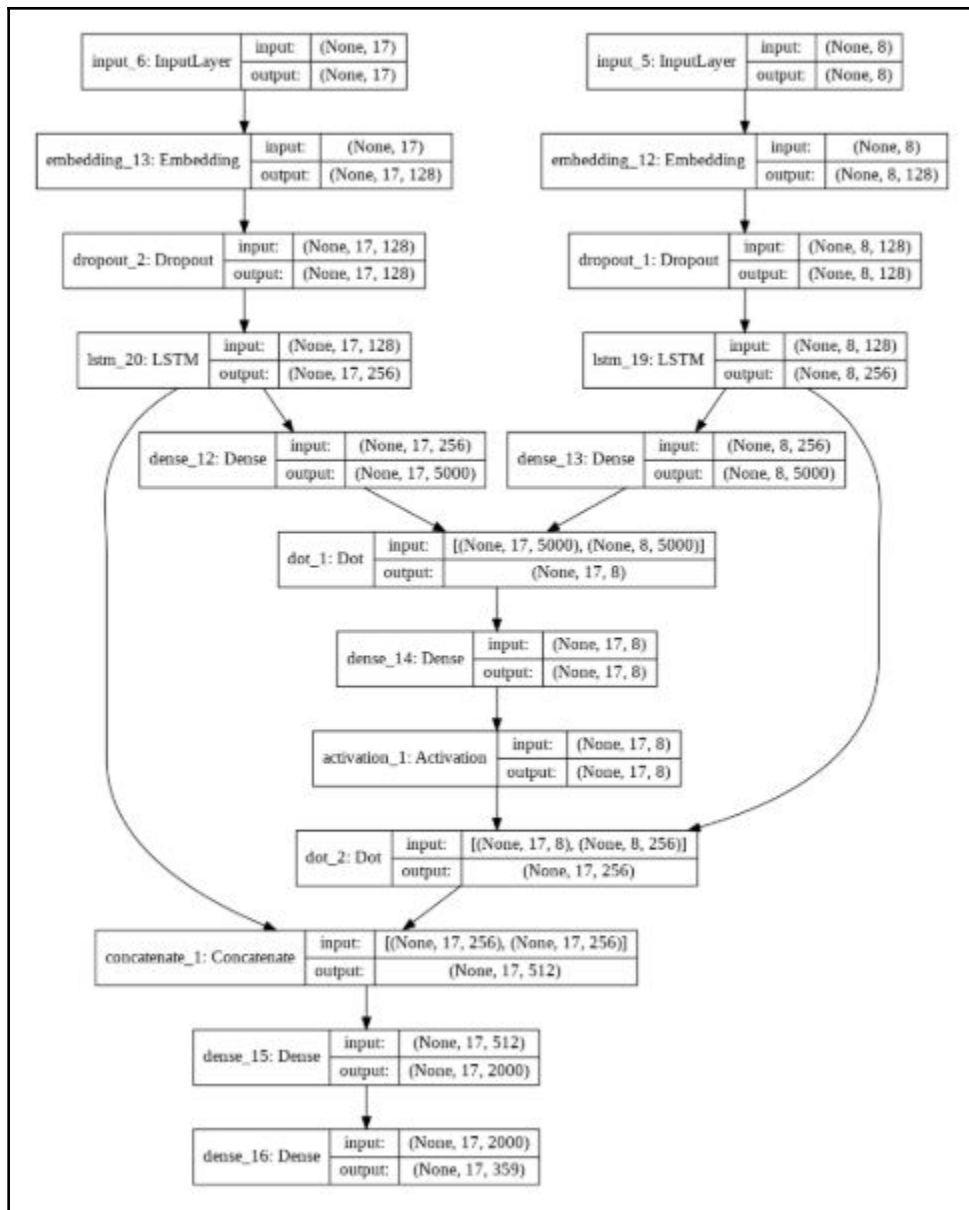

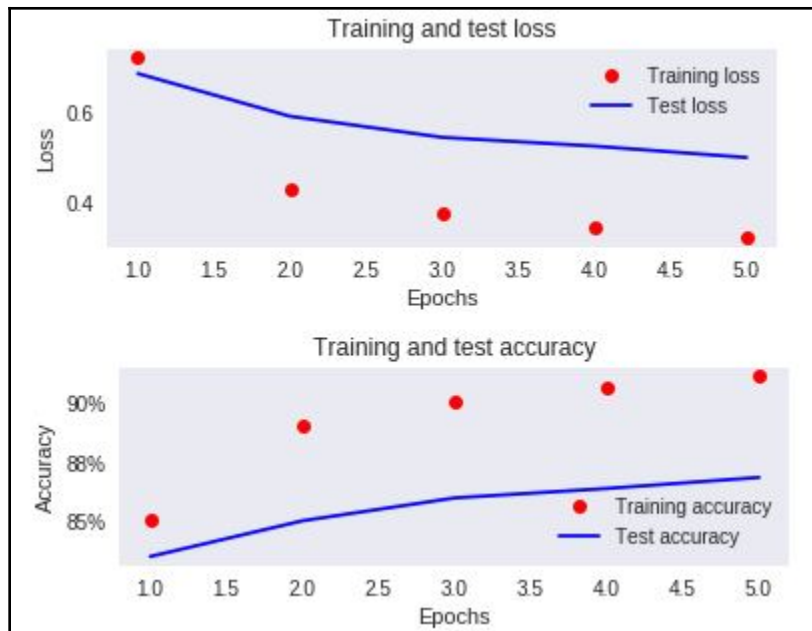

---

## Chapter 14: End-to-End Learning

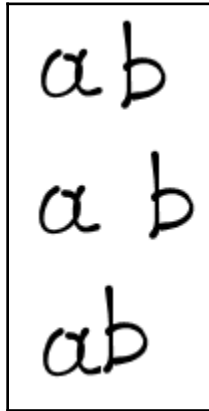

a b  
a b  
a b



a	b			
a	b			
a	b			

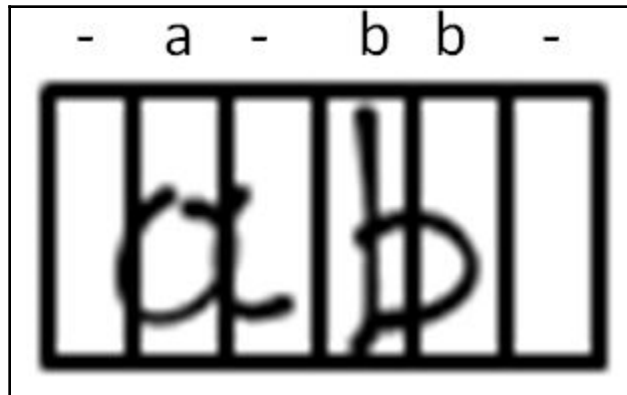

- a - b b -

a	b			
---	---	--	--	--

---

	t0	t1	t2	t3	t4	t5
a	0.2	0.9	0.1	0.1	0.1	0
b	0	0	0.1	0.8	0.9	0.1
-	0.8	0.1	0.8	0.1	0	0.9



	t0	t1	t2
a	0.2	0.9	0.1
b	0	0	0.1
-	0.8	0.1	0.8

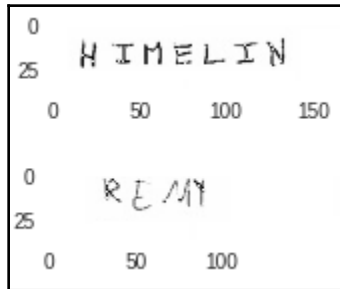

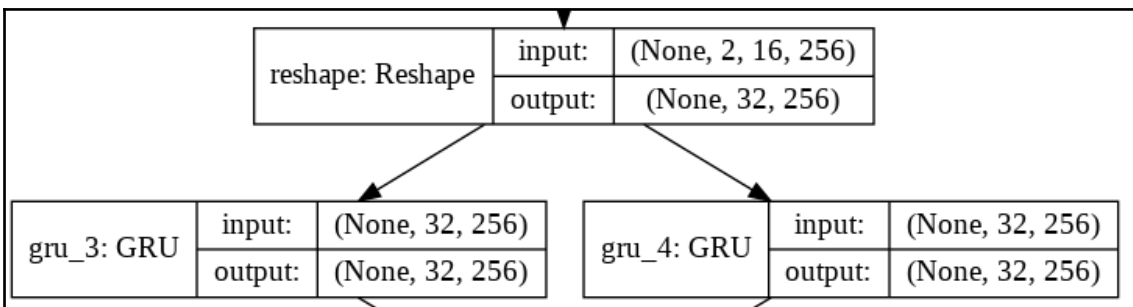
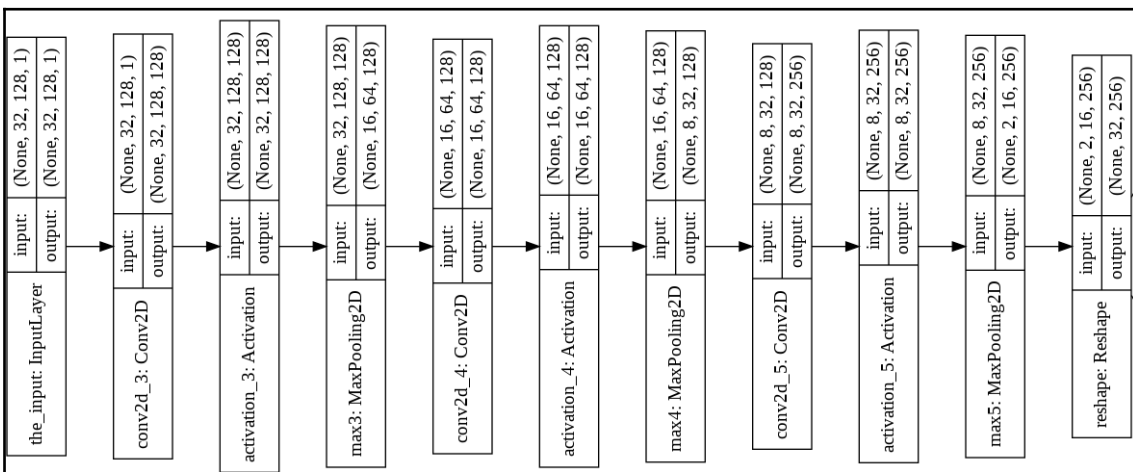
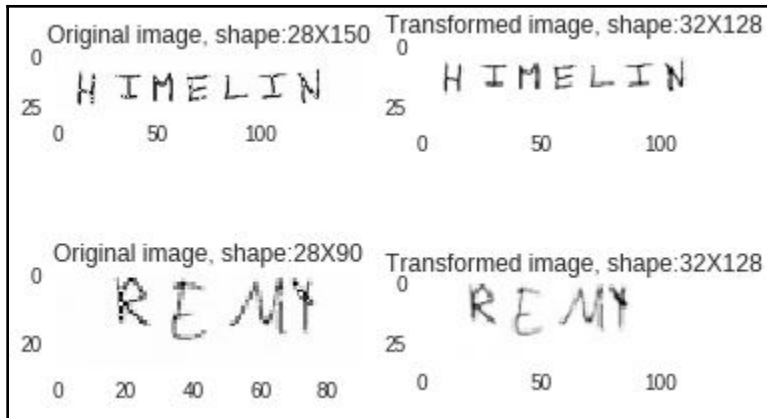

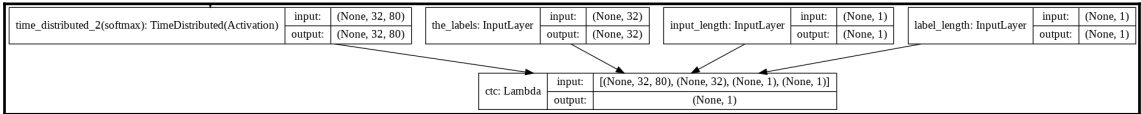
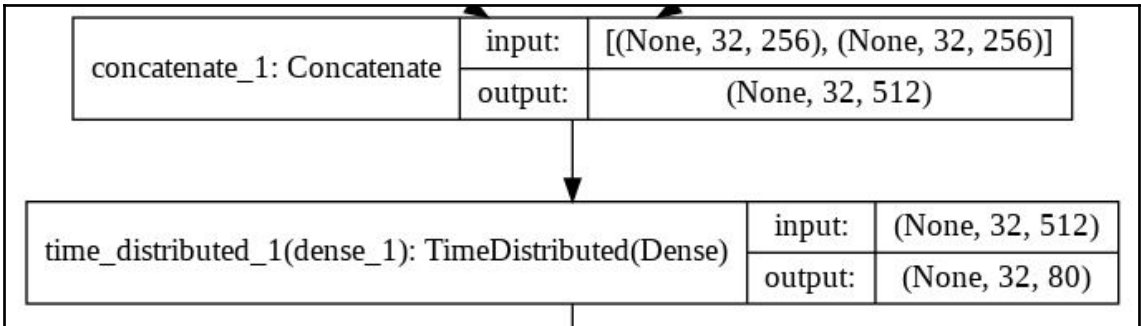
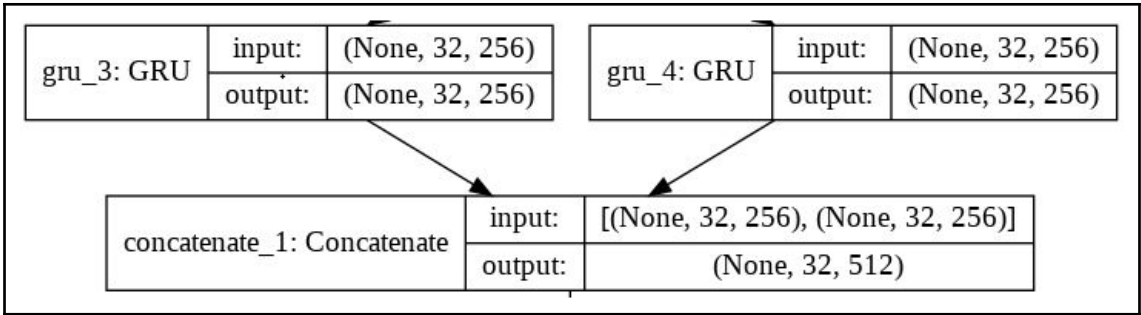

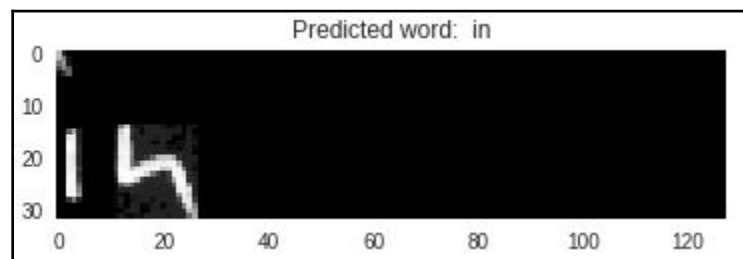
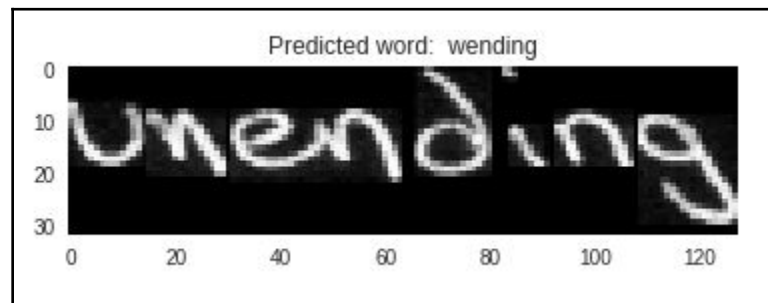
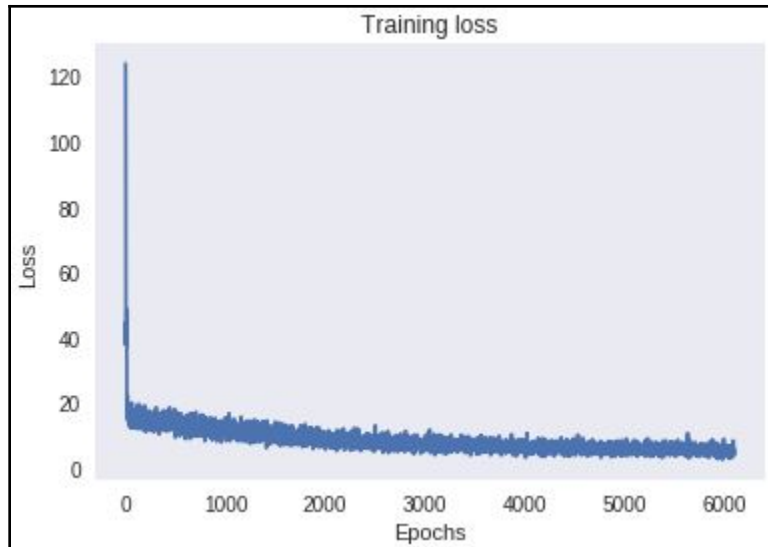

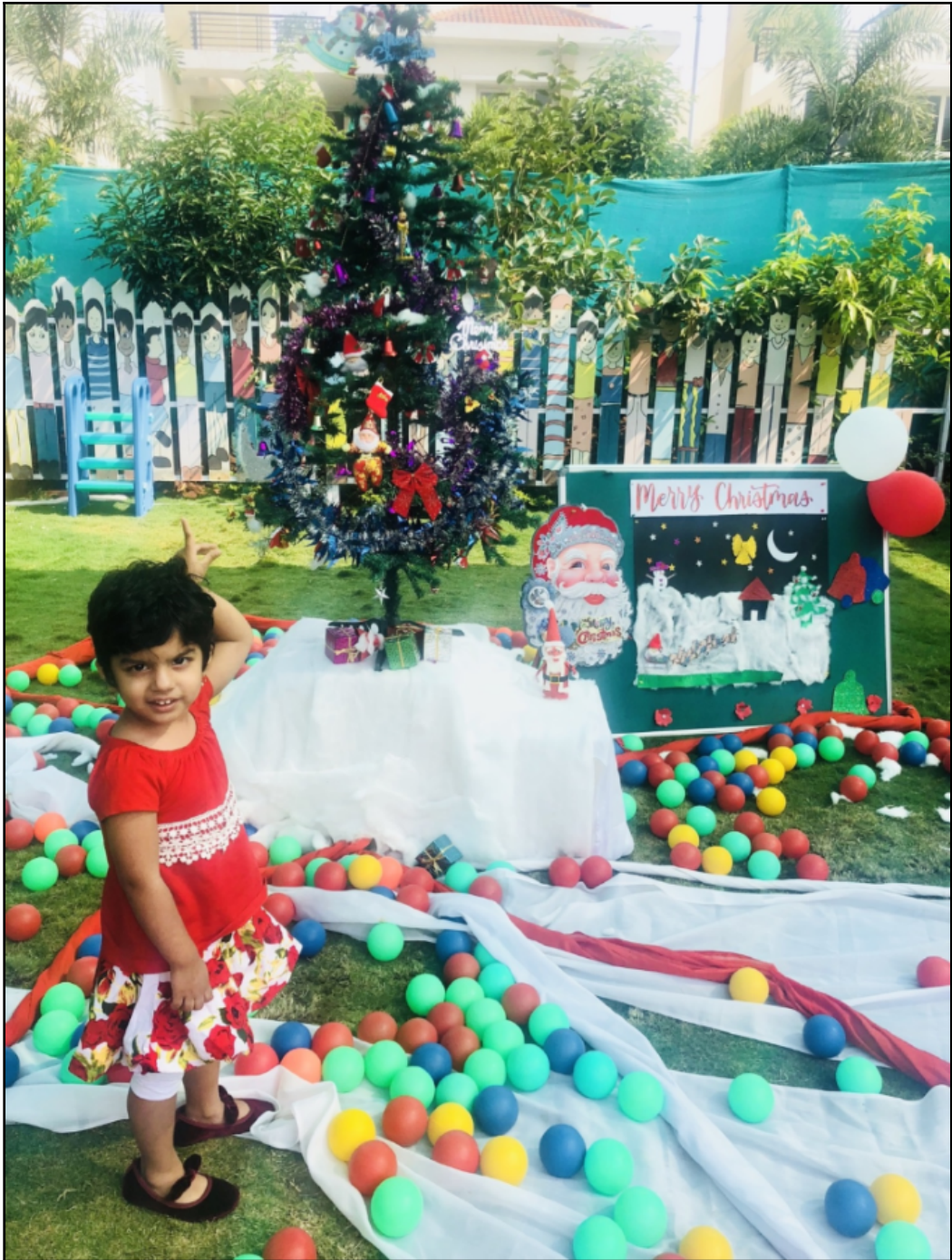



```
a  
black  
dog  
is  
jumping  
in  
the  
air  
<end>
```

```
<start>  
a  
black  
dog  
is  
playing  
in  
the  
grass  
<end>
```

---

```
<start>  
a  
black  
dog  
is  
jumping  
in  
the  
grass  
<end>
```

```
<start>  
a  
black  
dog  
is  
playing  
in  
the  
grass  
<end>
```



---

# Chapter 15: Audio Analysis

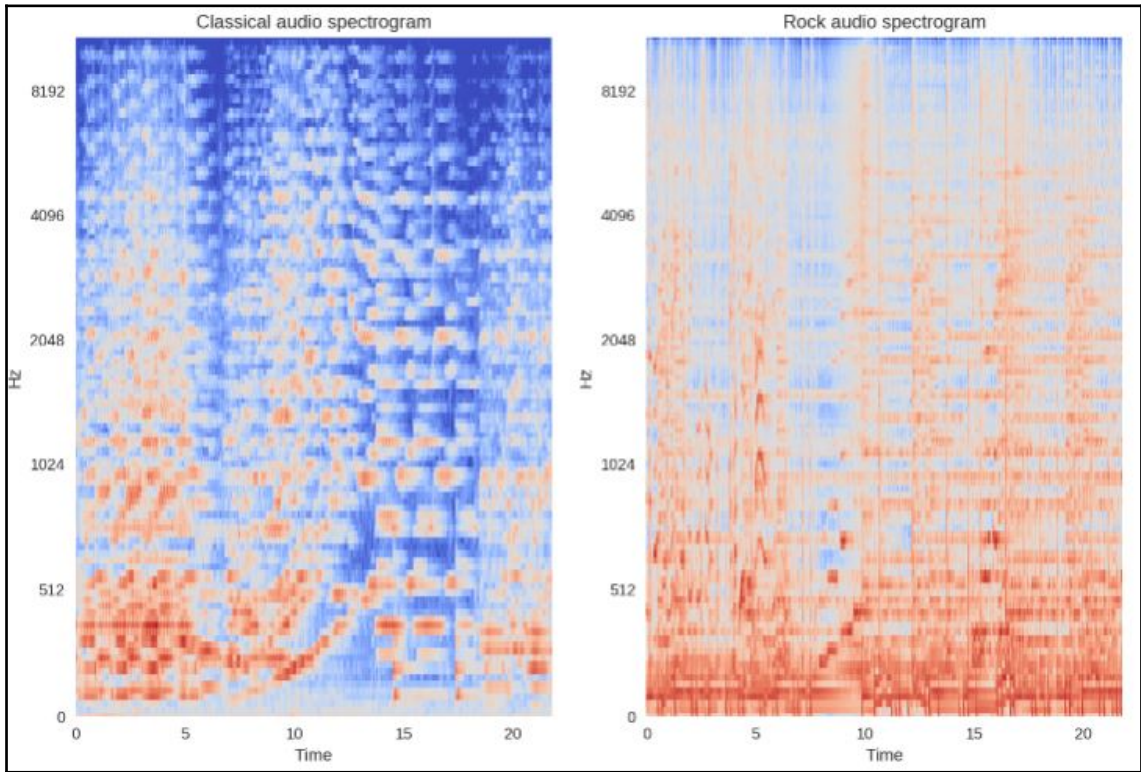



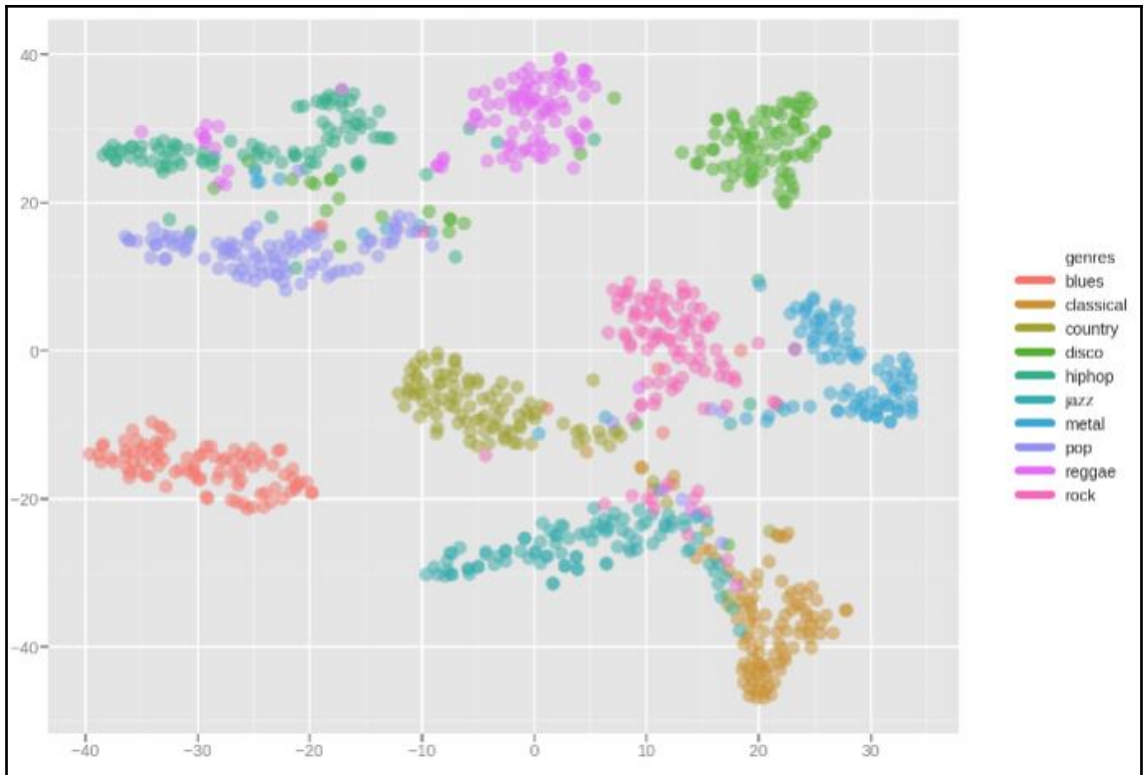

['#2.0', '#9.5', '#1.75', 'E-5', 'F5', 'E-3', 'G5', '#0.125', 'E-4', '3.7']

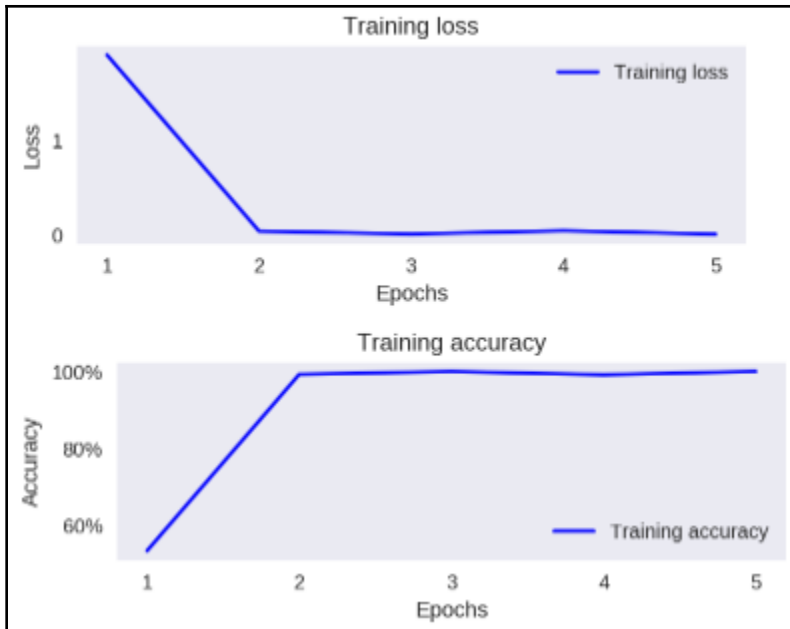

Layer (type)	Output Shape	Param #	Connected to
the_input (InputLayer)	(None, 999, 161)	0	
inp (BatchNormalization)	(None, 999, 161)	644	the_input[0][0]
conv1d_3 (Conv1D)	(None, 495, 220)	389840	inp[0][0]
Normal_0 (BatchNormalization)	(None, 495, 220)	880	conv1d_3[0][0]
conv1d_4 (Conv1D)	(None, 243, 220)	532620	Normal_0[0][0]
Normal_1 (BatchNormalization)	(None, 243, 220)	880	conv1d_4[0][0]
gru_3 (GRU)	(None, 243, 512)	1125888	Normal_1[0][0]
gru_4 (GRU)	(None, 243, 512)	1125888	Normal_1[0][0]
concatenate_1 (Concatenate)	(None, 243, 1024)	0	gru_3[0][0] gru_4[0][0]
Normal_2 (BatchNormalization)	(None, 243, 1024)	4096	concatenate_1[0][0]
time_distributed_1 (TimeDistrib	(None, 243, 30)	30750	Normal_2[0][0]
time_distributed_2 (TimeDistrib	(None, 243, 30)	0	time_distributed_1[0][0]
Total params: 3,211,486			
Trainable params: 3,208,236			
Non-trainable params: 3,250			

HAT ONTED BYTHO MY POARL OTHE MOUG WESPRN FOURRS S SO LON

I FOUND IT BY THE NINTH PARALLEL OFF THE NORTHWESTERN SHORES OF CEYLON

---

# Chapter 16: Reinforcement Learning

--	--	--

1	1	2
2	1	1

S		
		+1

```
[0.729000000000000001, 0.81, 0.9]  
[0.81, 0.9, 1]
```

S		-1
		+1

```
[0.729000000000000001, -0.9, -1]  
[0.81, 0.9, 1]
```

S	FFF
	FHFH
	FFFH
	HFFG

---

S	F	F	F
F	H	F	H
F	F	F	H
H	F	F	G

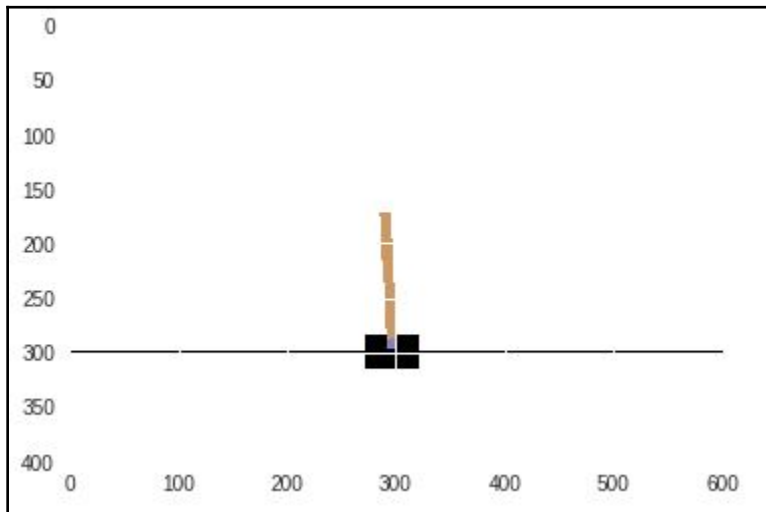



Layer (type)	Output Shape	Param #
conv2d_1 (Conv2D)	(None, 26, 20, 32)	8224
conv2d_2 (Conv2D)	(None, 12, 9, 64)	32832
conv2d_3 (Conv2D)	(None, 5, 4, 128)	73856
flatten_1 (Flatten)	(None, 2560)	0
dense_1 (Dense)	(None, 512)	1311232
dense_2 (Dense)	(None, 3)	1539
=====		
Total params: 1,427,683		
Trainable params: 1,427,683		
Non-trainable params: 0		

