

Chapter 1: Foundations of Artificial Intelligence Based Systems

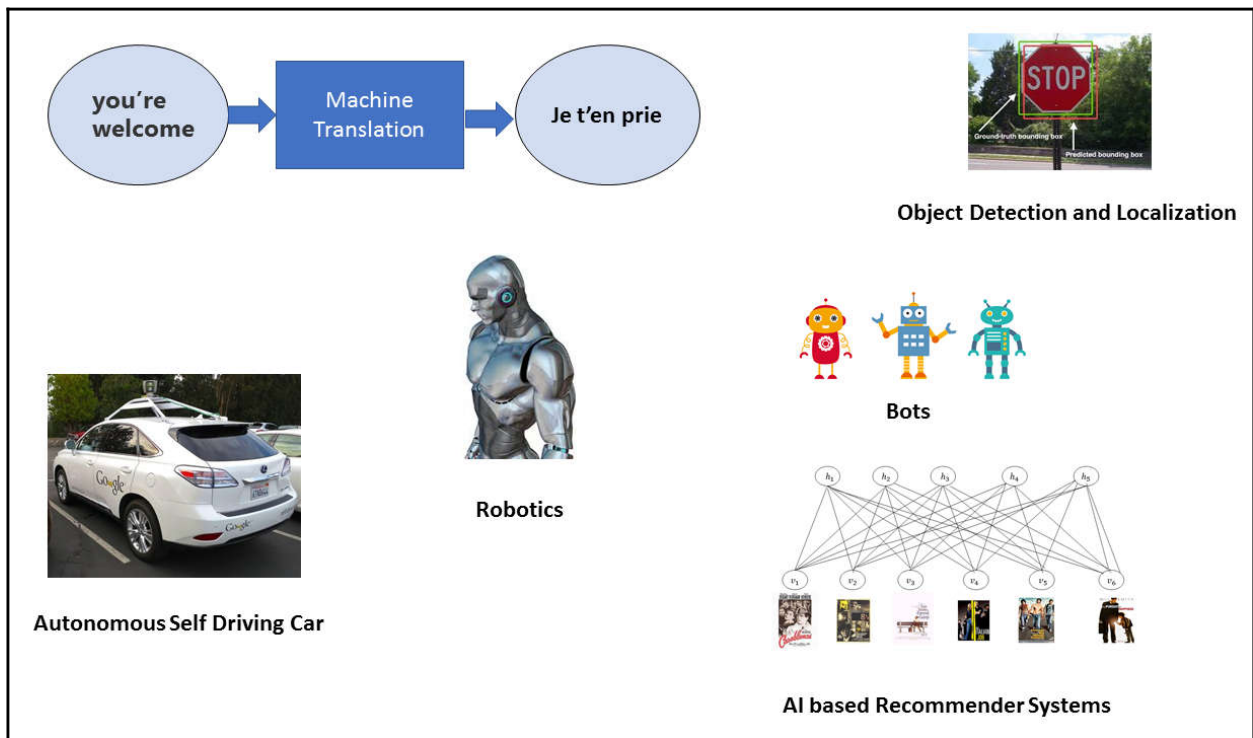

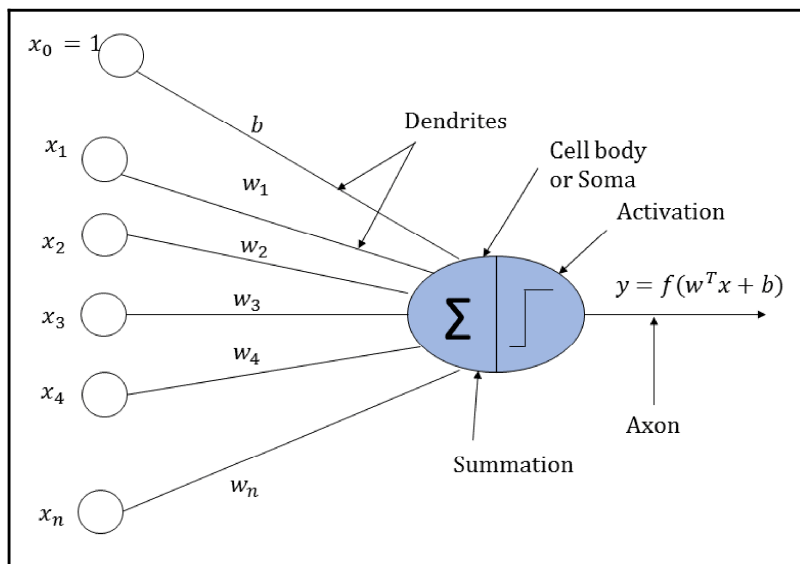

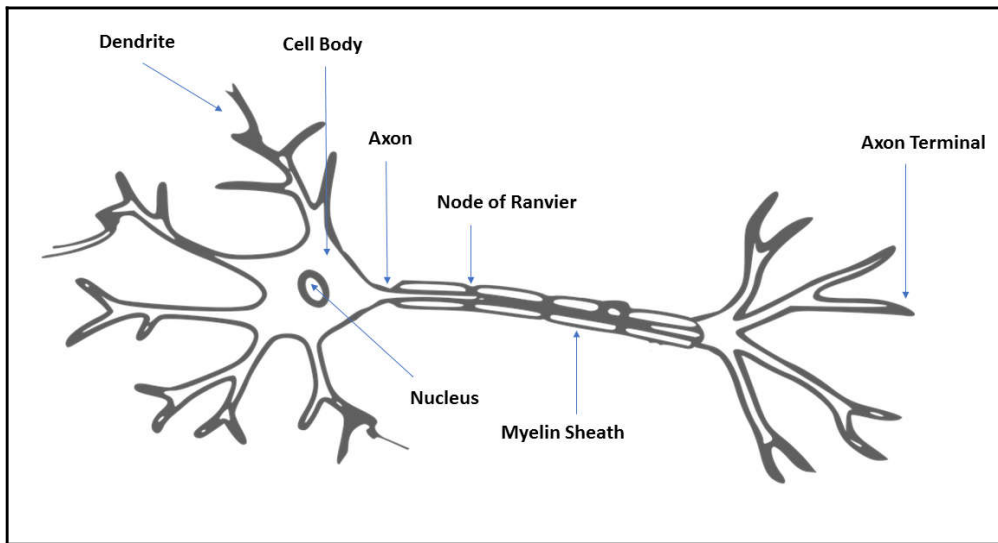

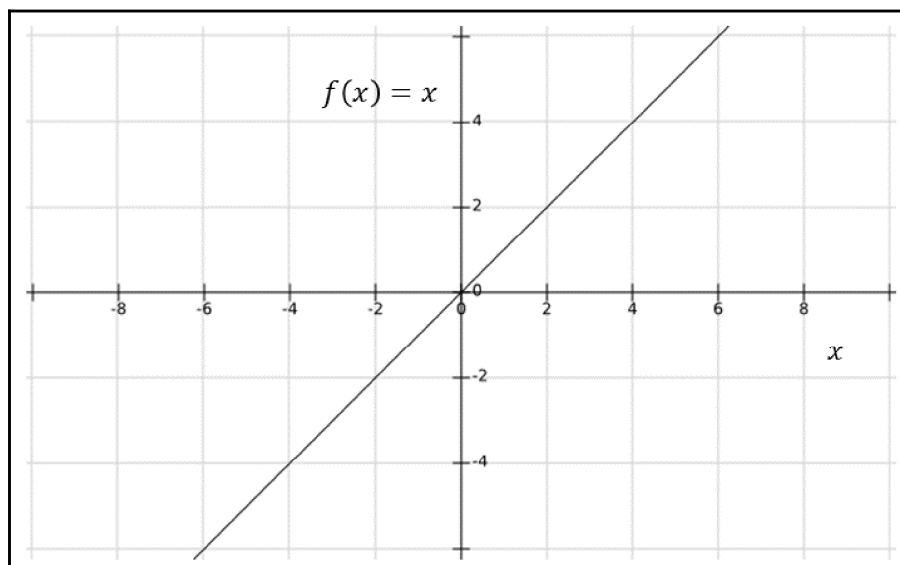
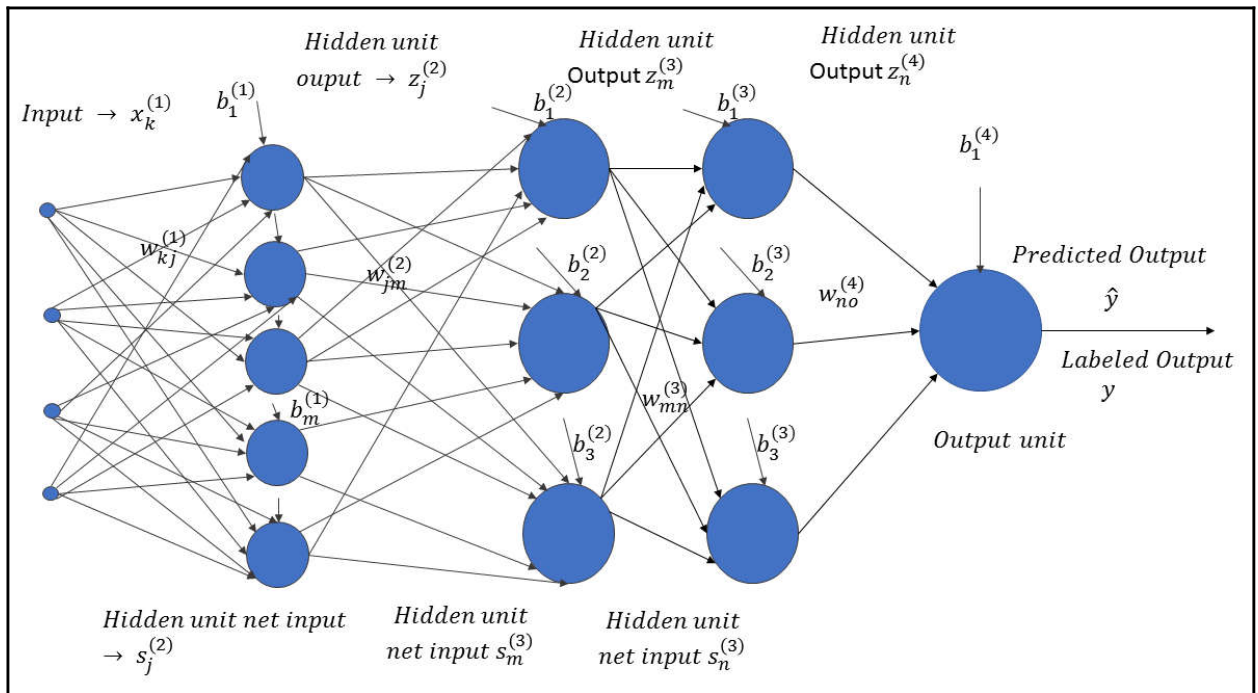
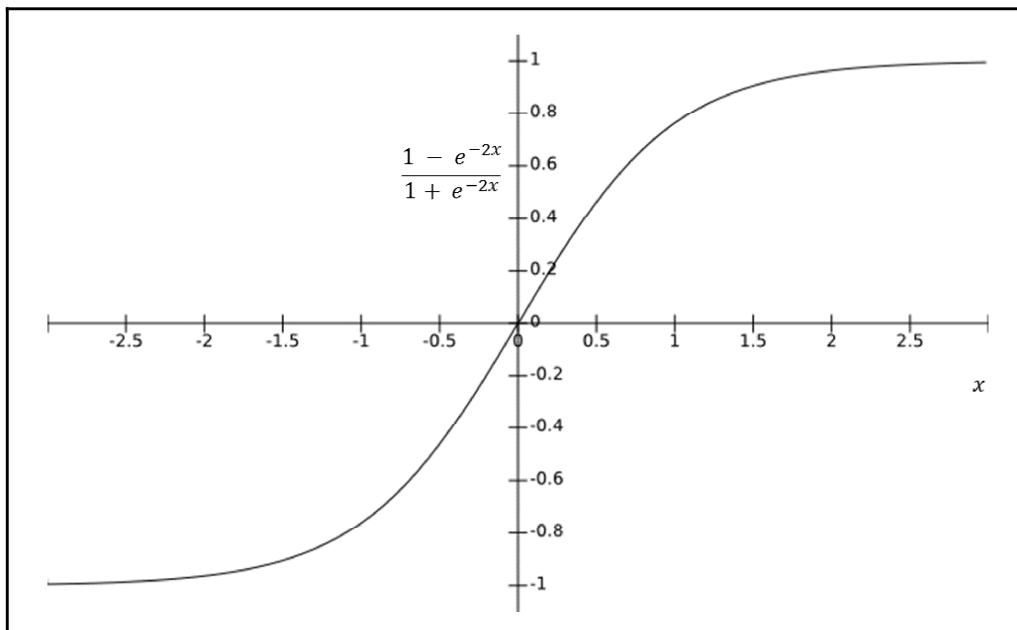
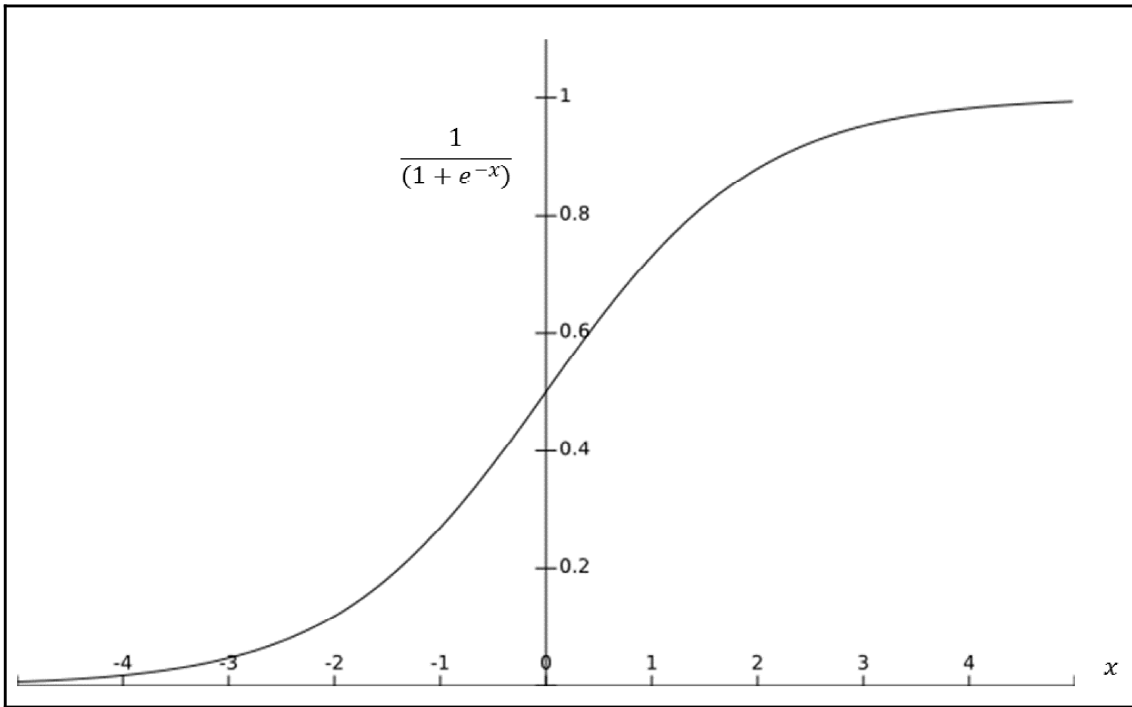

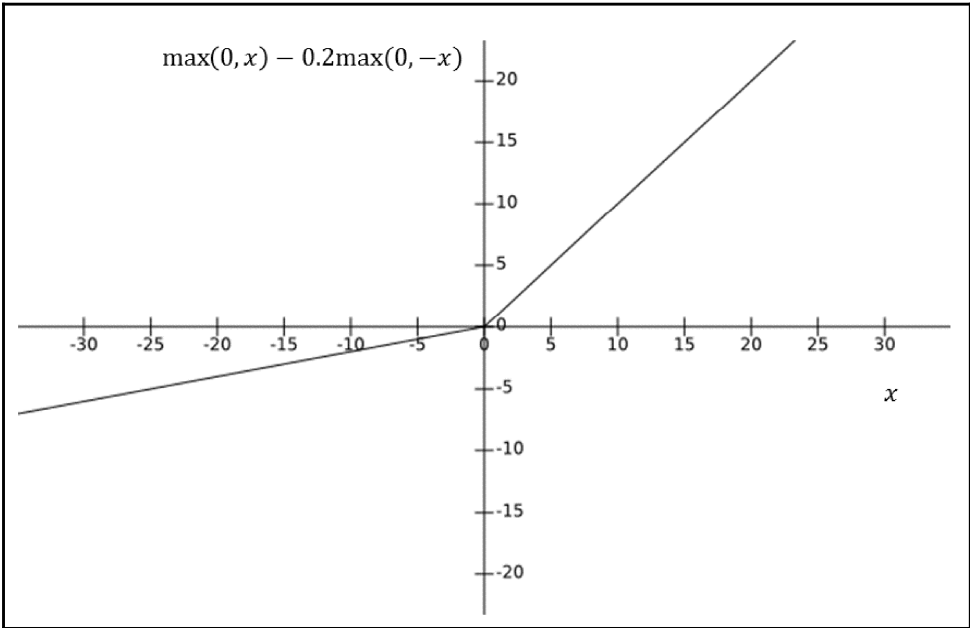
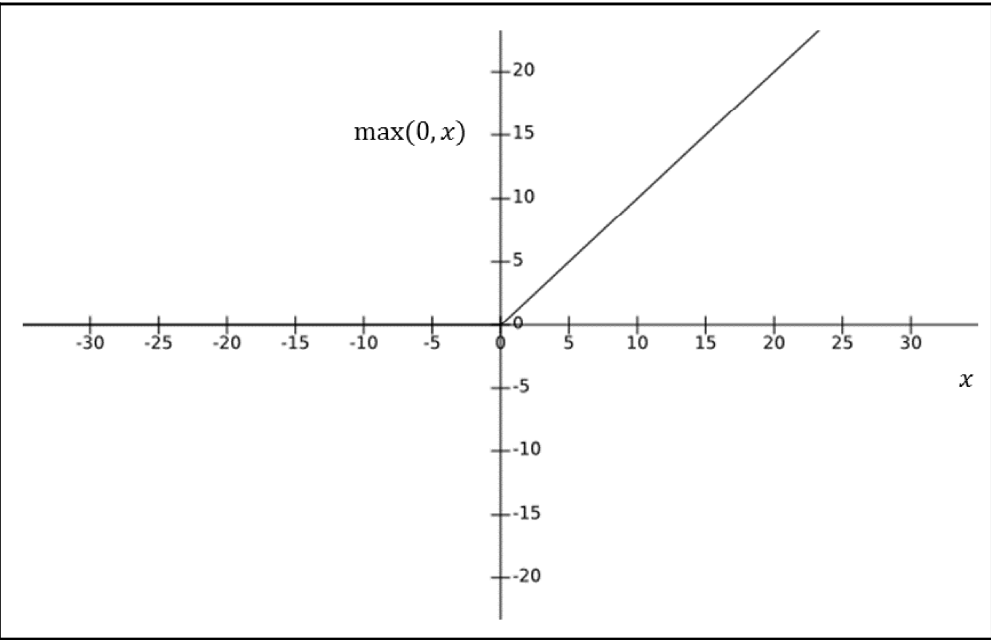

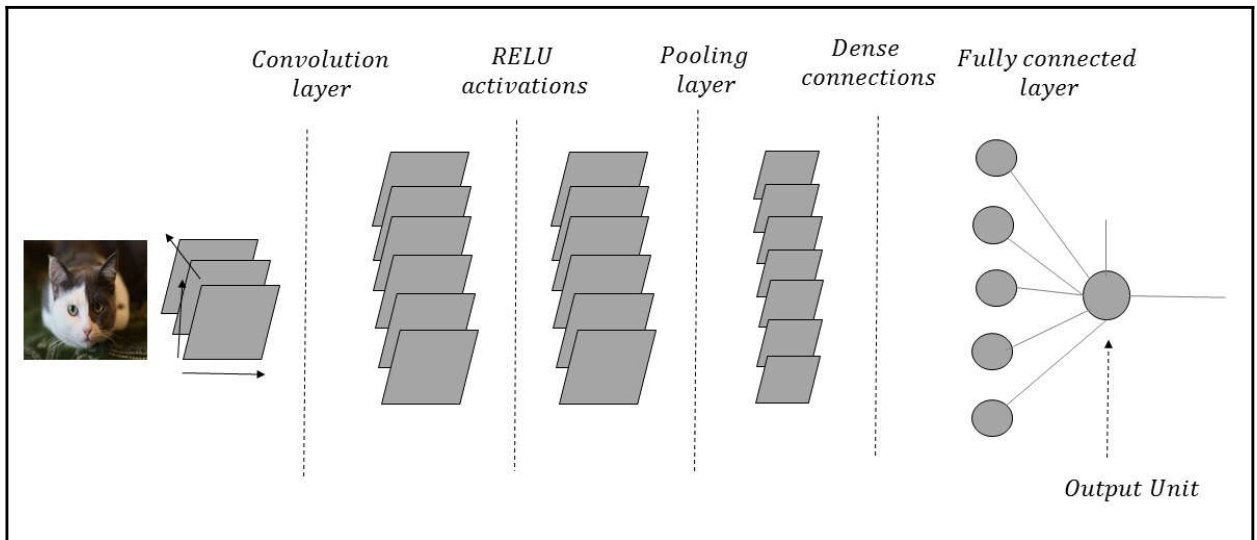
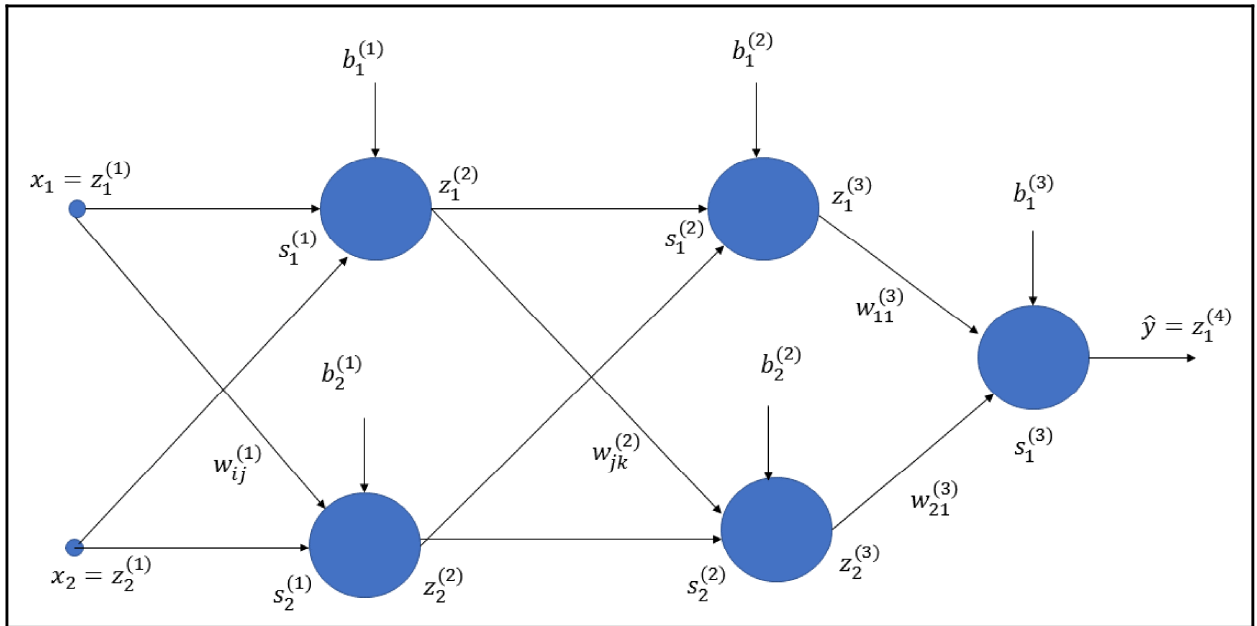

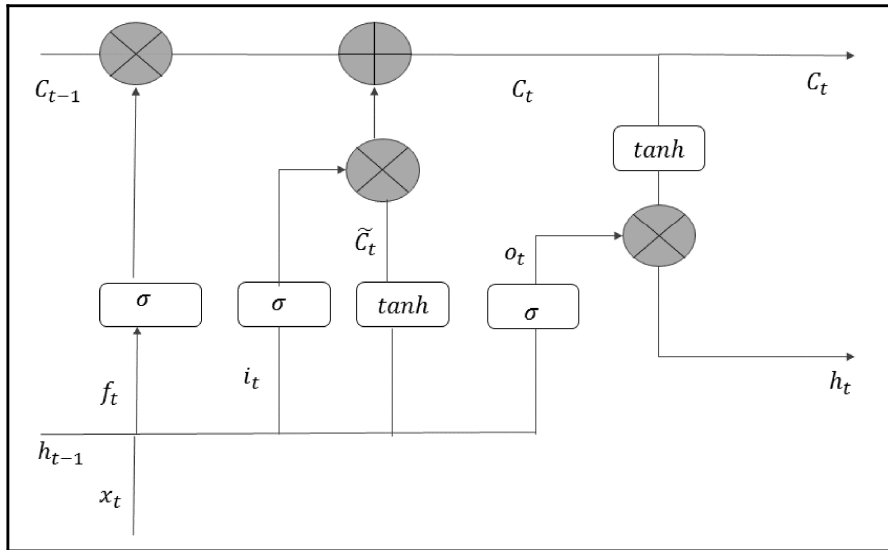
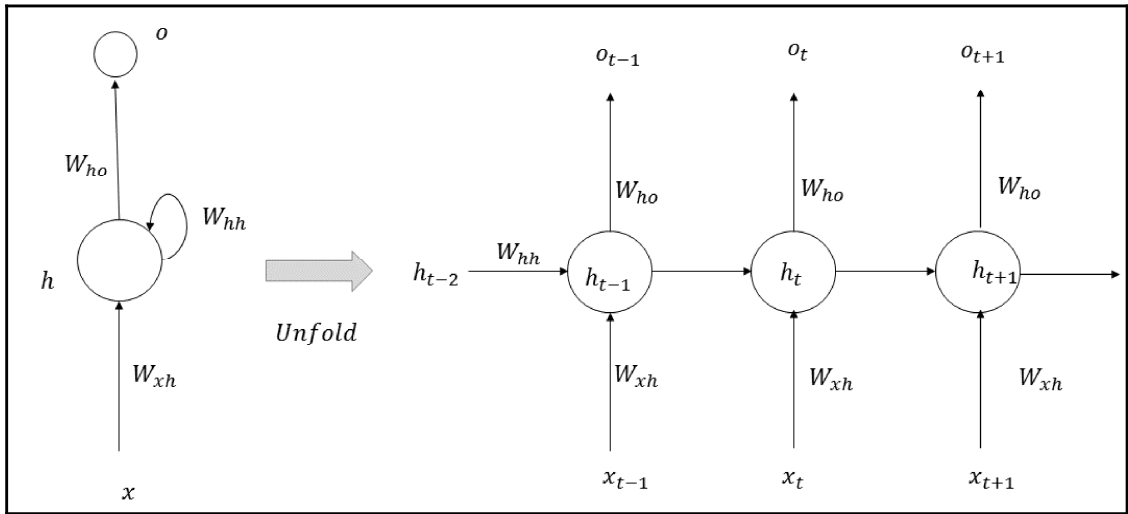

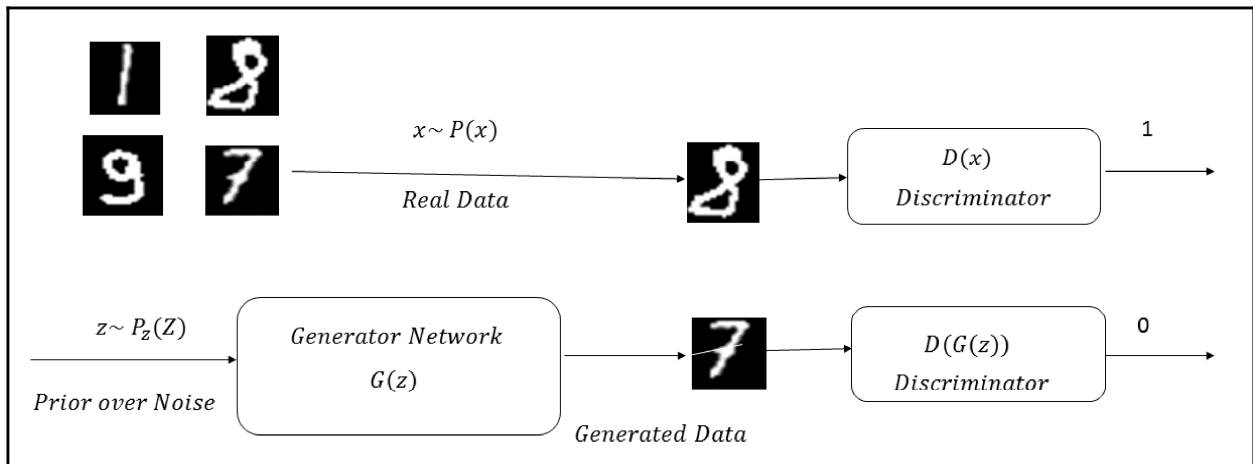

$$U(G, D) = -\mathbb{E}_{x \sim P(x)} [\log D(x)] - \mathbb{E}_{G(z) \sim P(G(z))} [\log(1 - D(G(z)))] \quad (1)$$

$$\underbrace{\min}_D \underbrace{\max}_G U(G, D) = \underbrace{\min}_D \underbrace{\max}_G -\mathbb{E}_{x \sim P(x)} [\log D(x)] - \mathbb{E}_{G(z) \sim P(G(z))} [\log(1 - D(G(z)))] \quad (2)$$

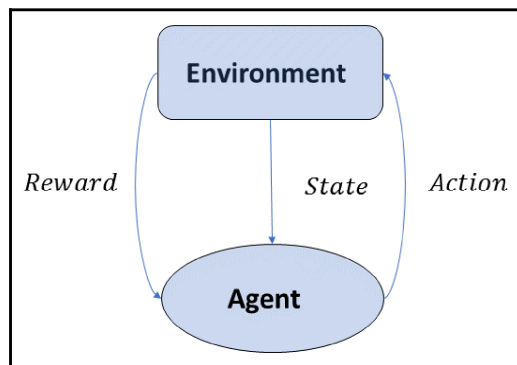

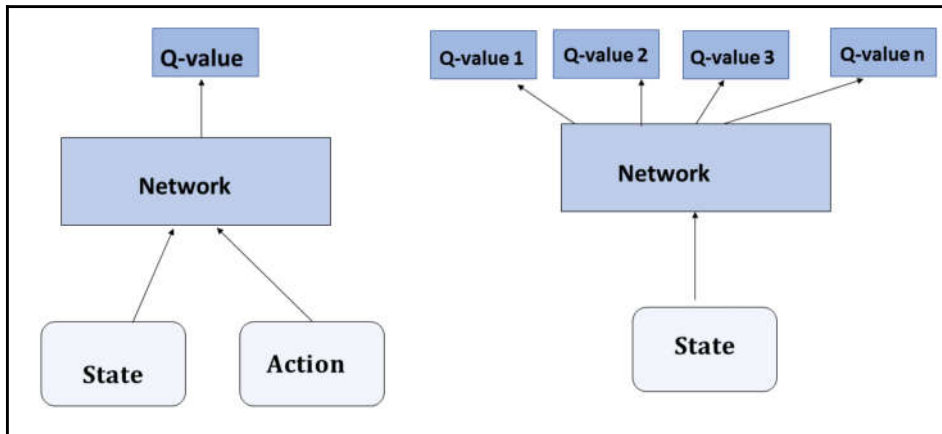
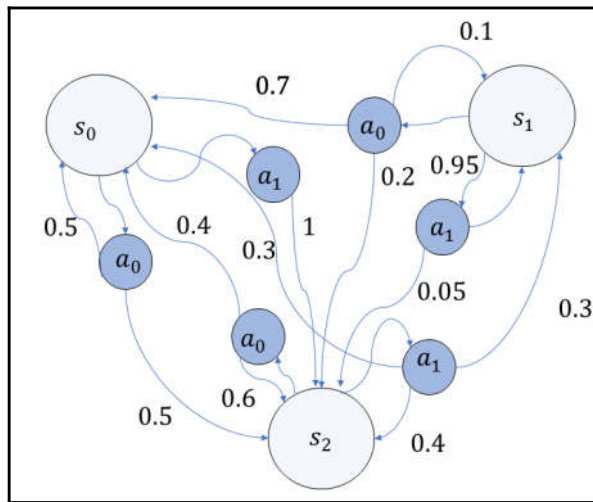

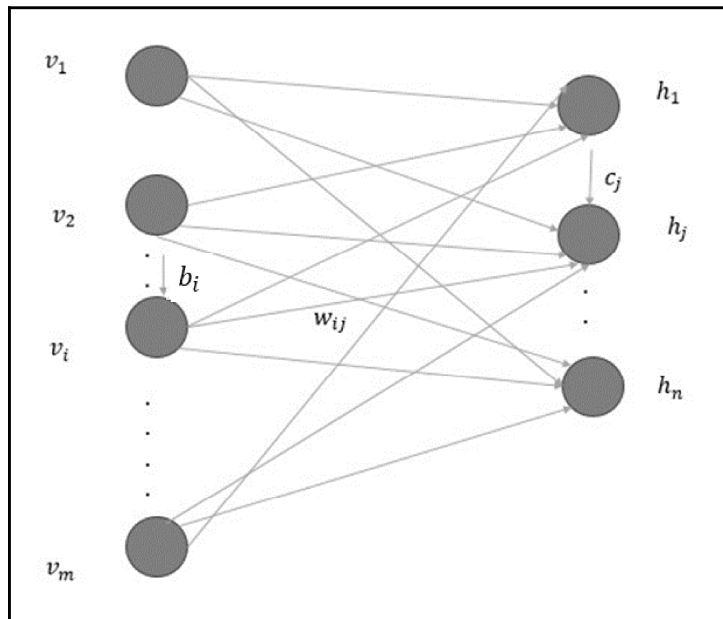
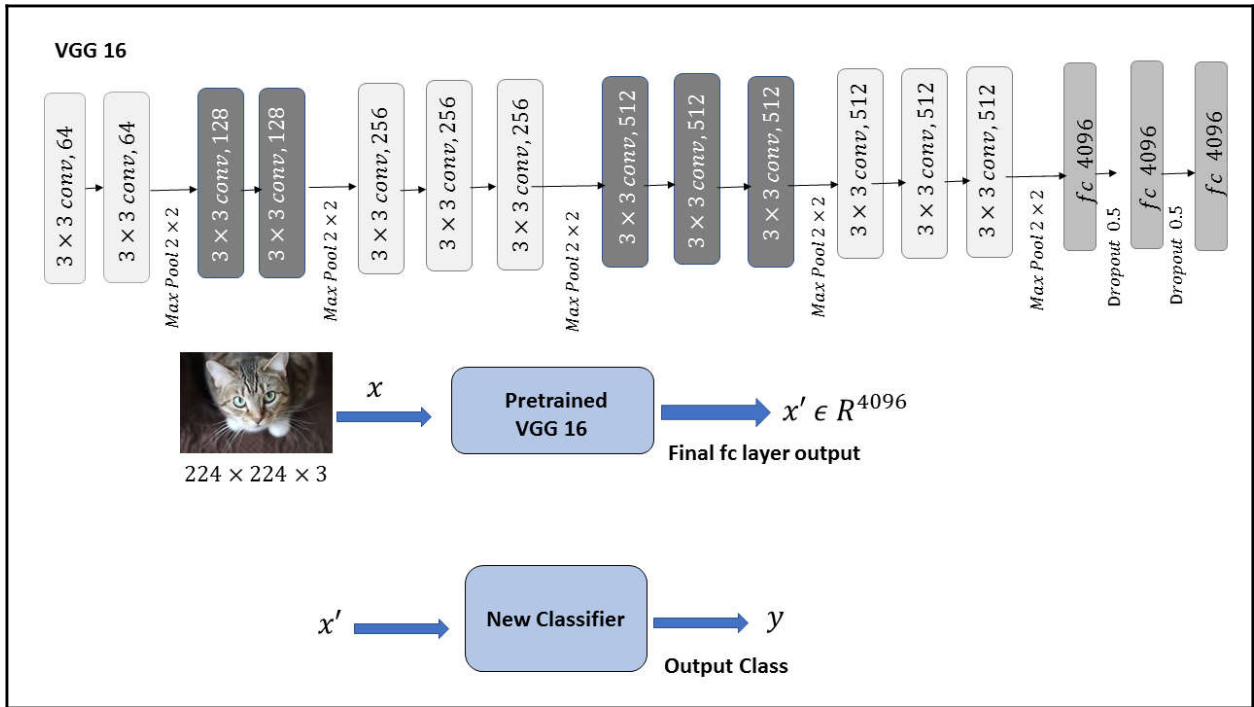

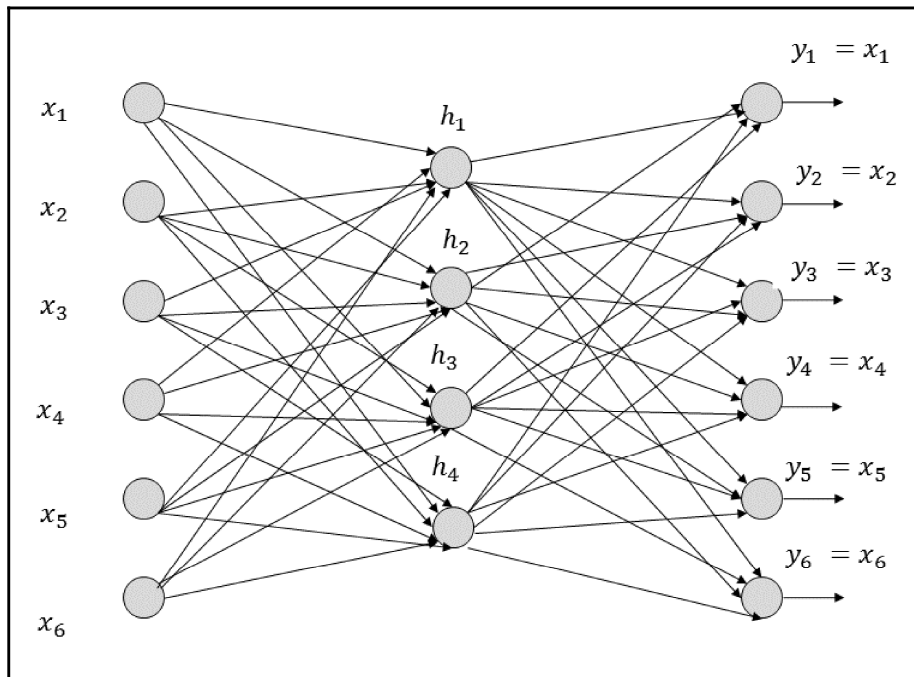

Chapter 2: Transfer Learning

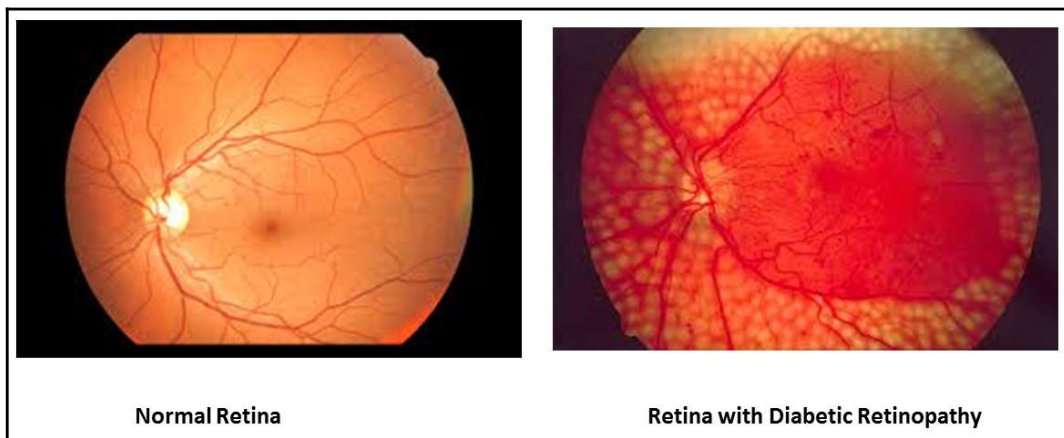
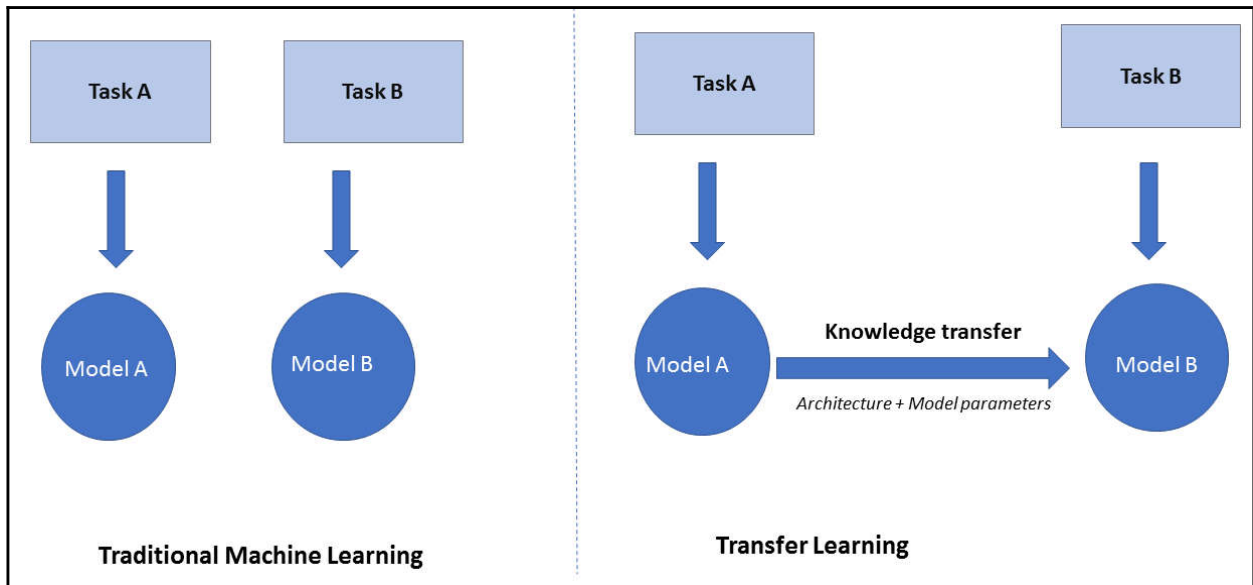

	Apple	Orange	<i>Predicted</i>
Apple	10	7	↓
Orange	5	8	
<i>Actual</i>	→		

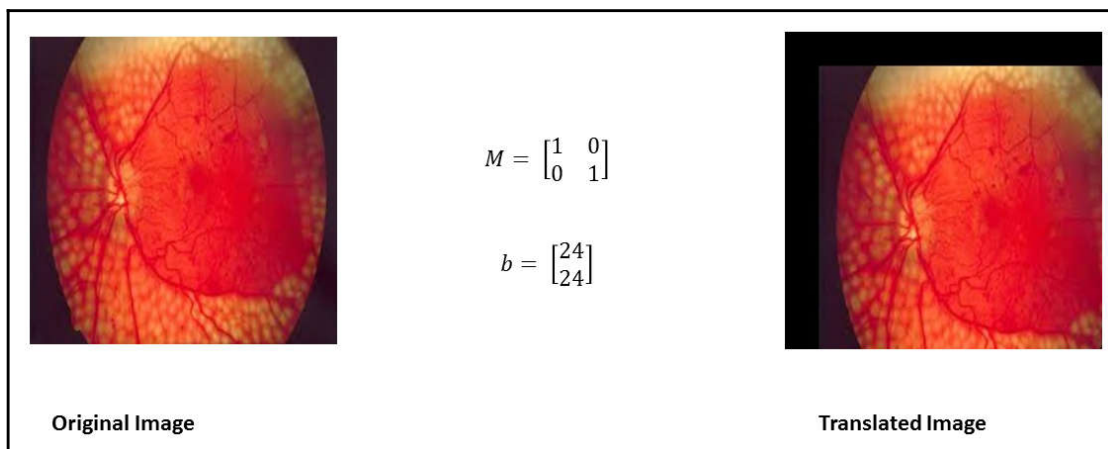
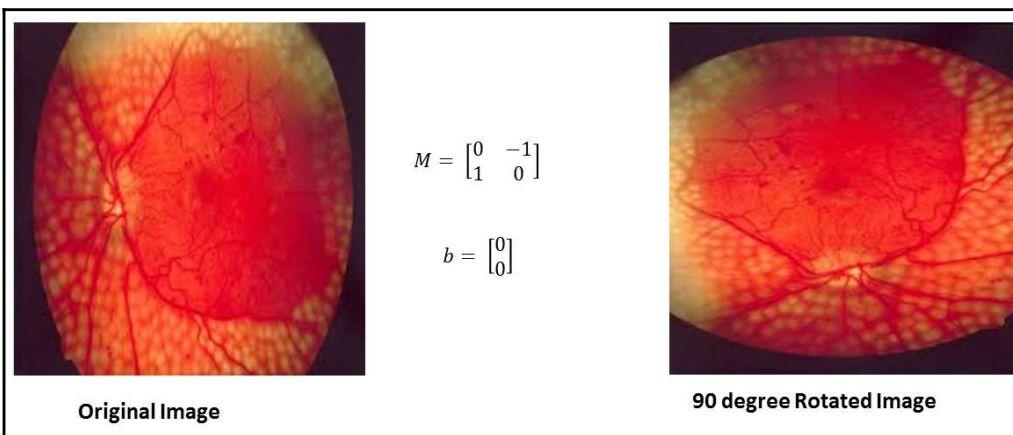
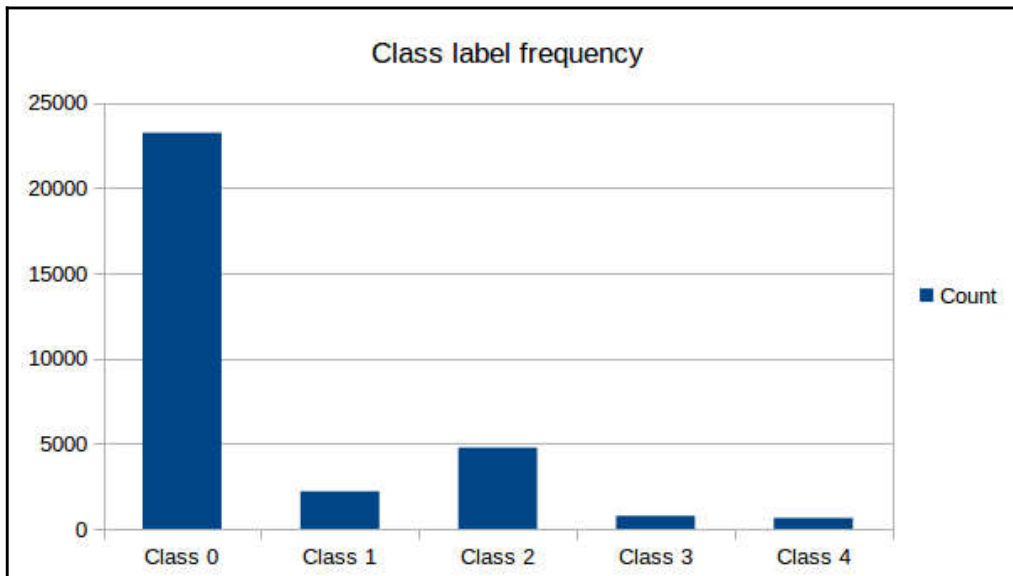



Original Image

$$M = \begin{bmatrix} 1.5 & 0 \\ 0 & 1.5 \end{bmatrix}$$

$$b = \begin{bmatrix} 0 \\ 0 \end{bmatrix}$$



Scaled Image



Original Image

$$M = \begin{bmatrix} 1 & 0 \\ 0 & -1 \end{bmatrix}$$

$$b = \begin{bmatrix} 0 \\ 0 \end{bmatrix}$$



Horizontally Flipped Image

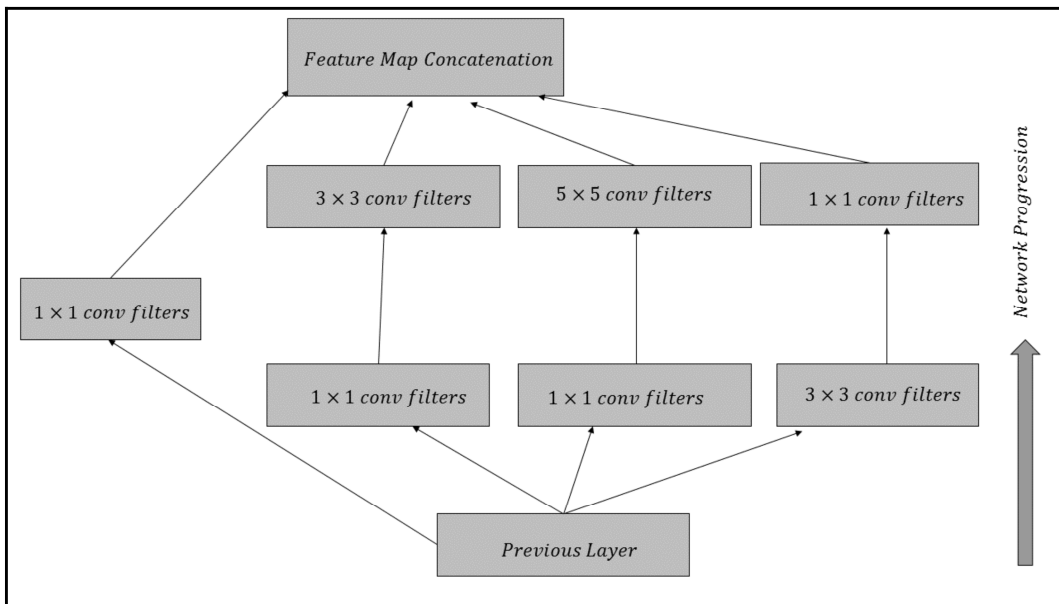
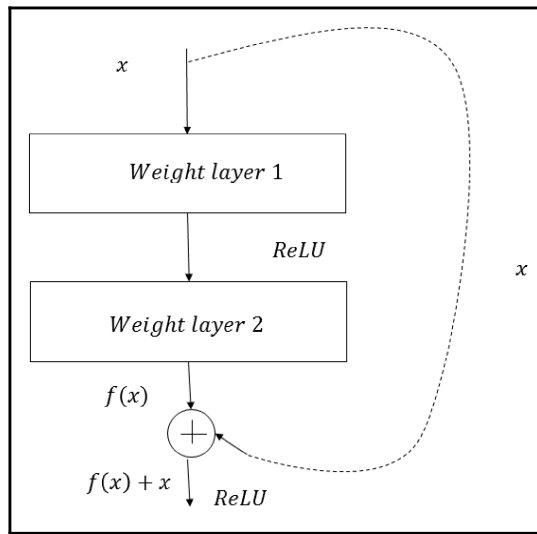

All Convolutions with stride 1 and pad 1
Max Pooling with stride 2

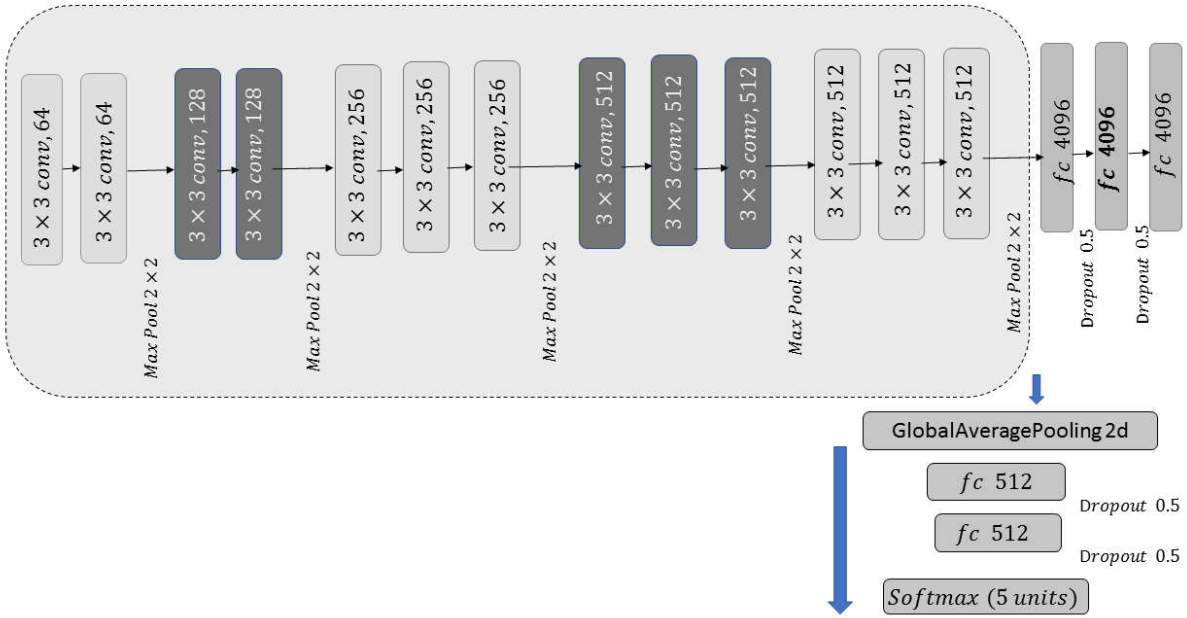

Chapter 3: Neural Machine Translation

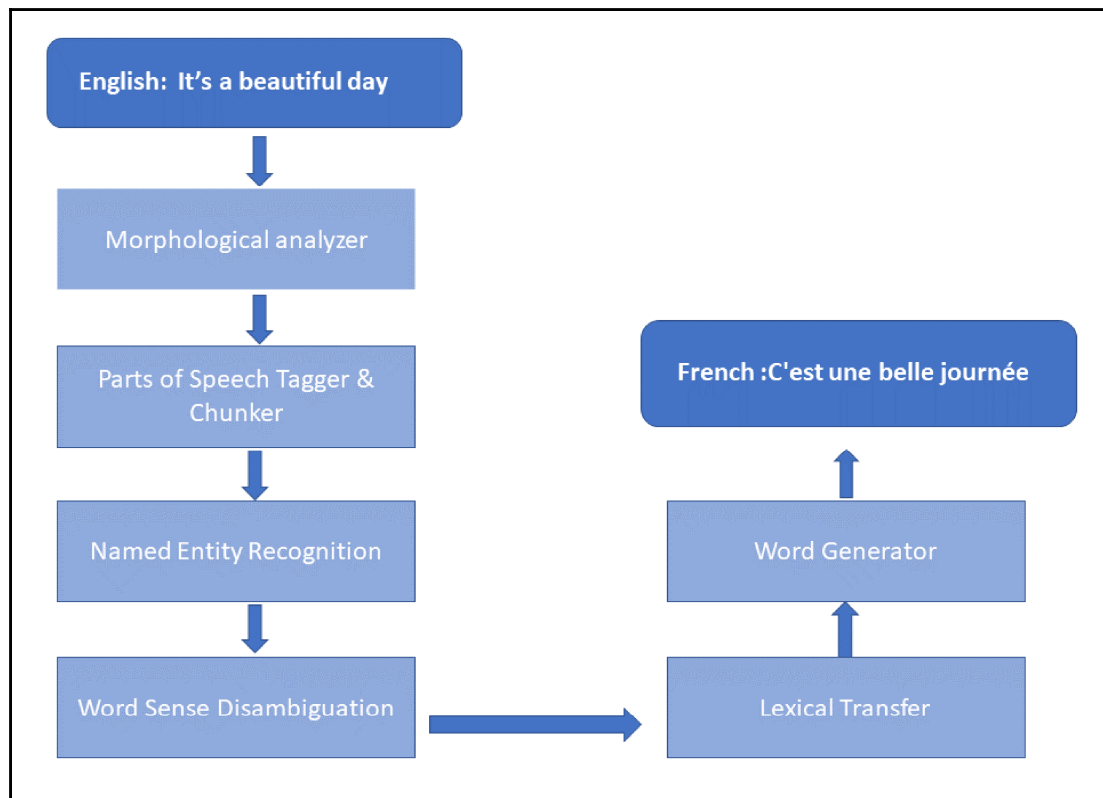

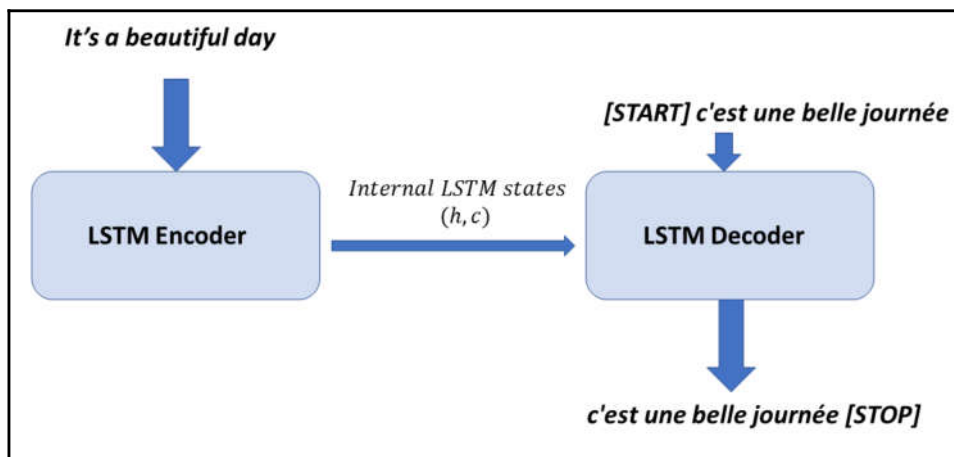
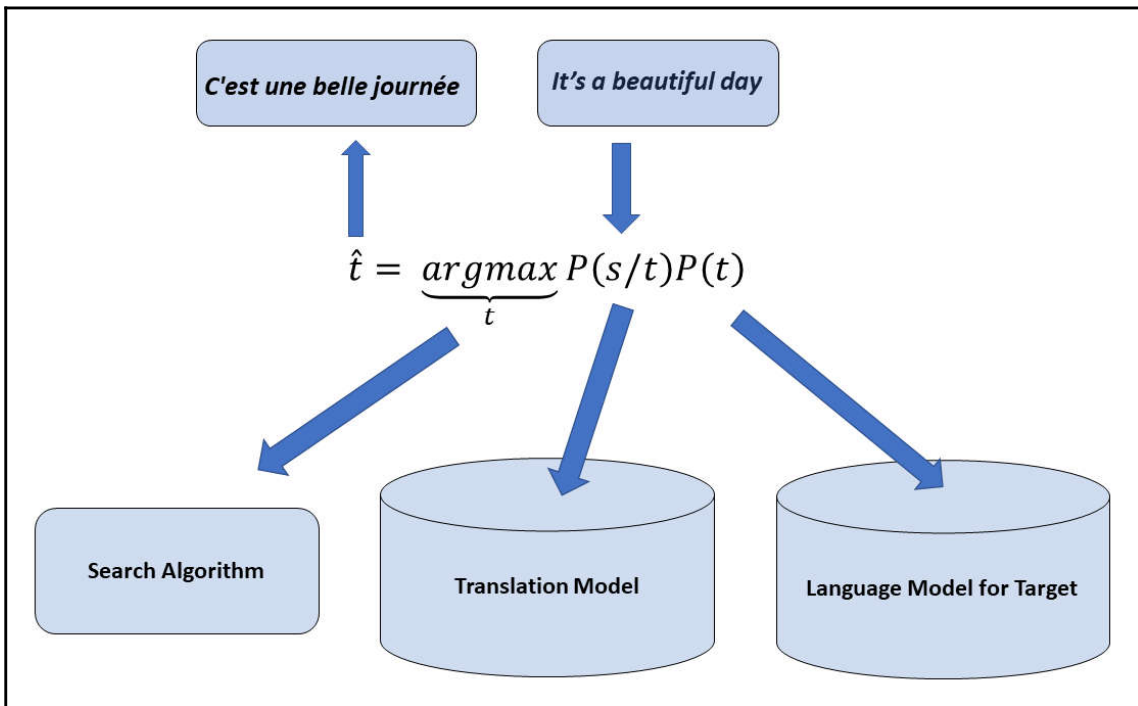

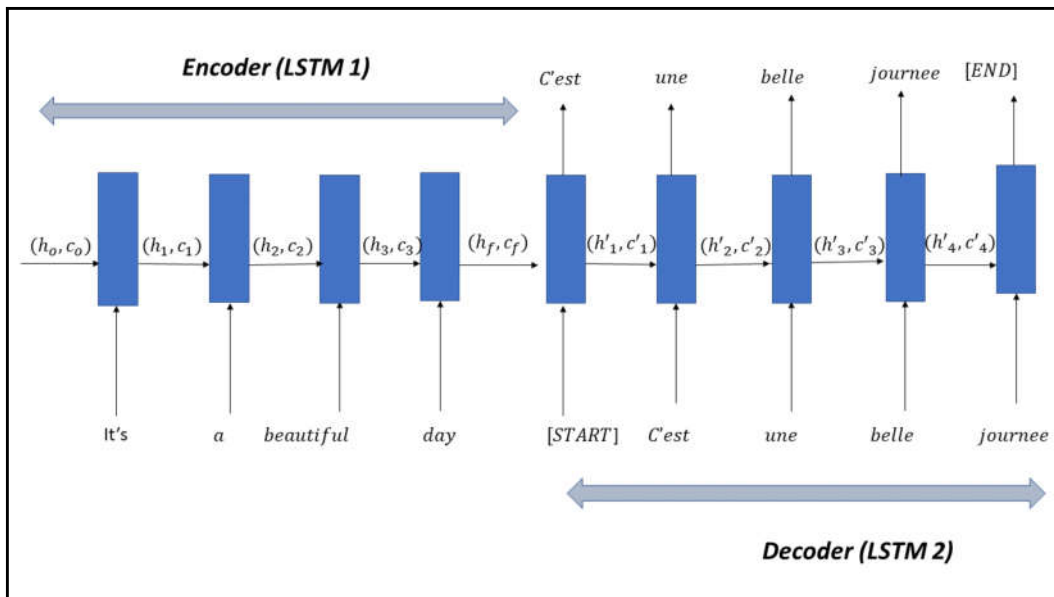
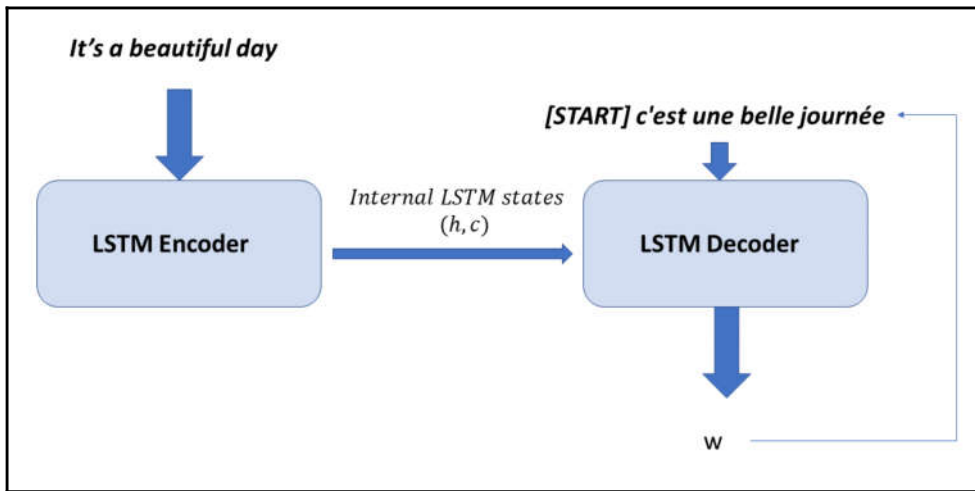

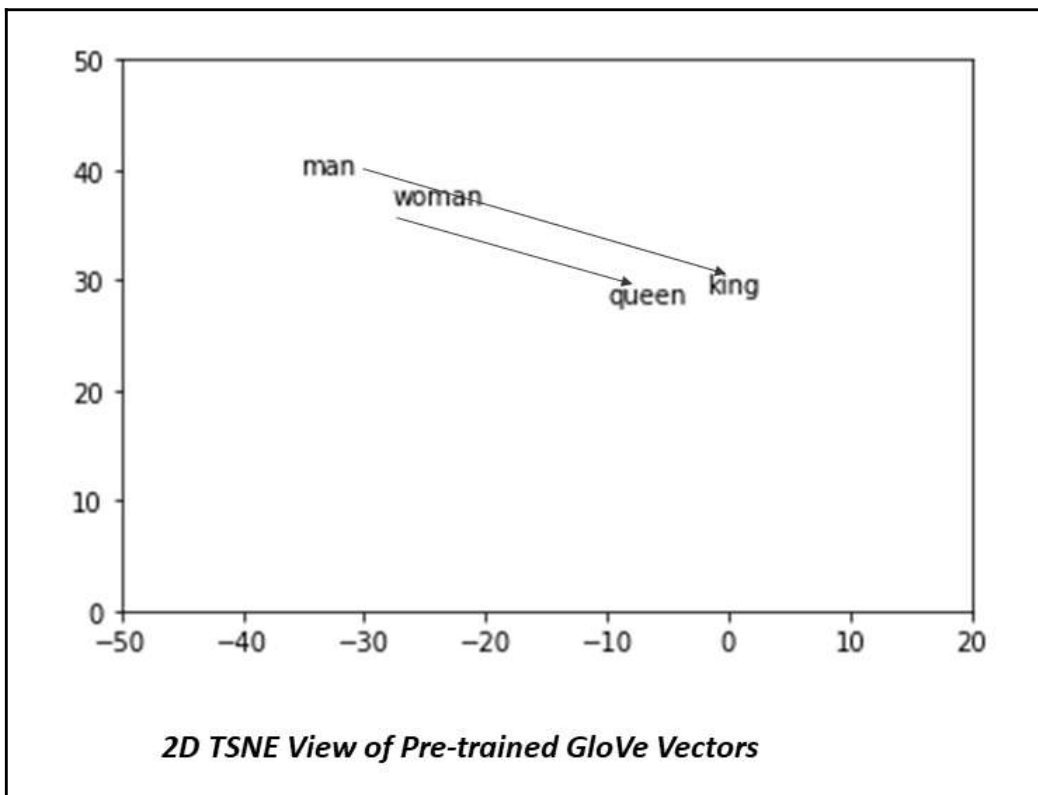
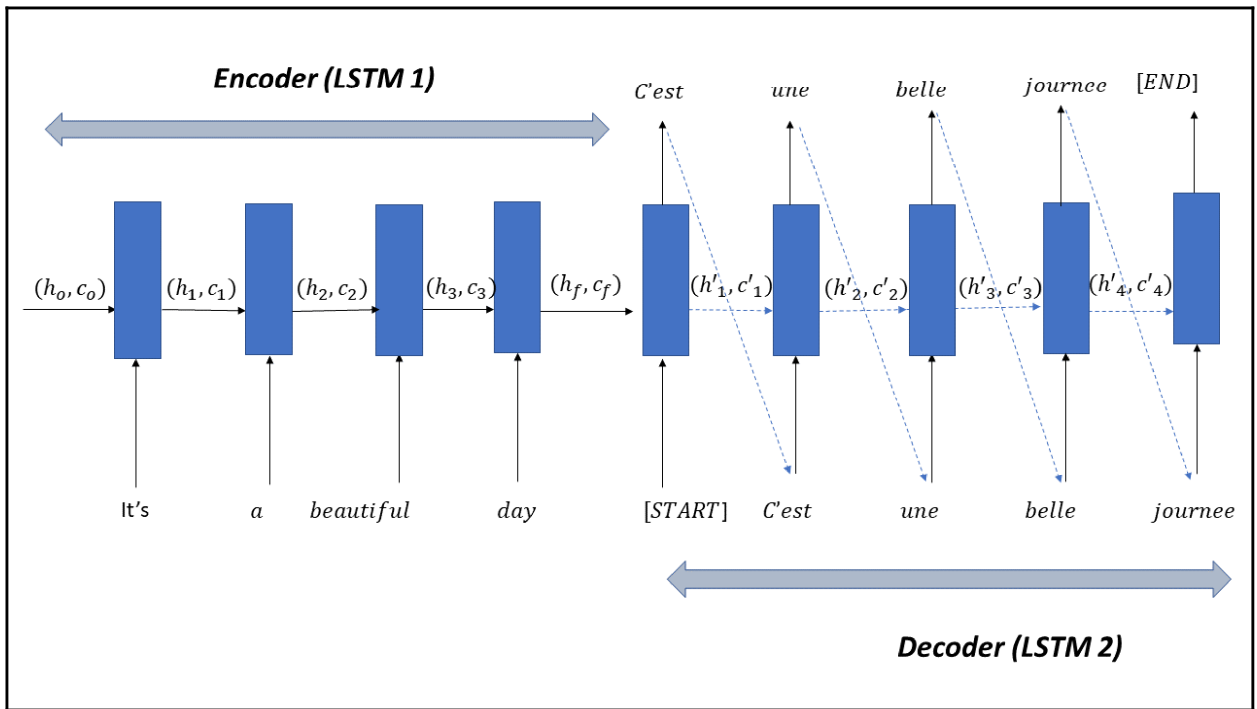

Chapter 4: Style Transfer in Fashion Industry using GANs

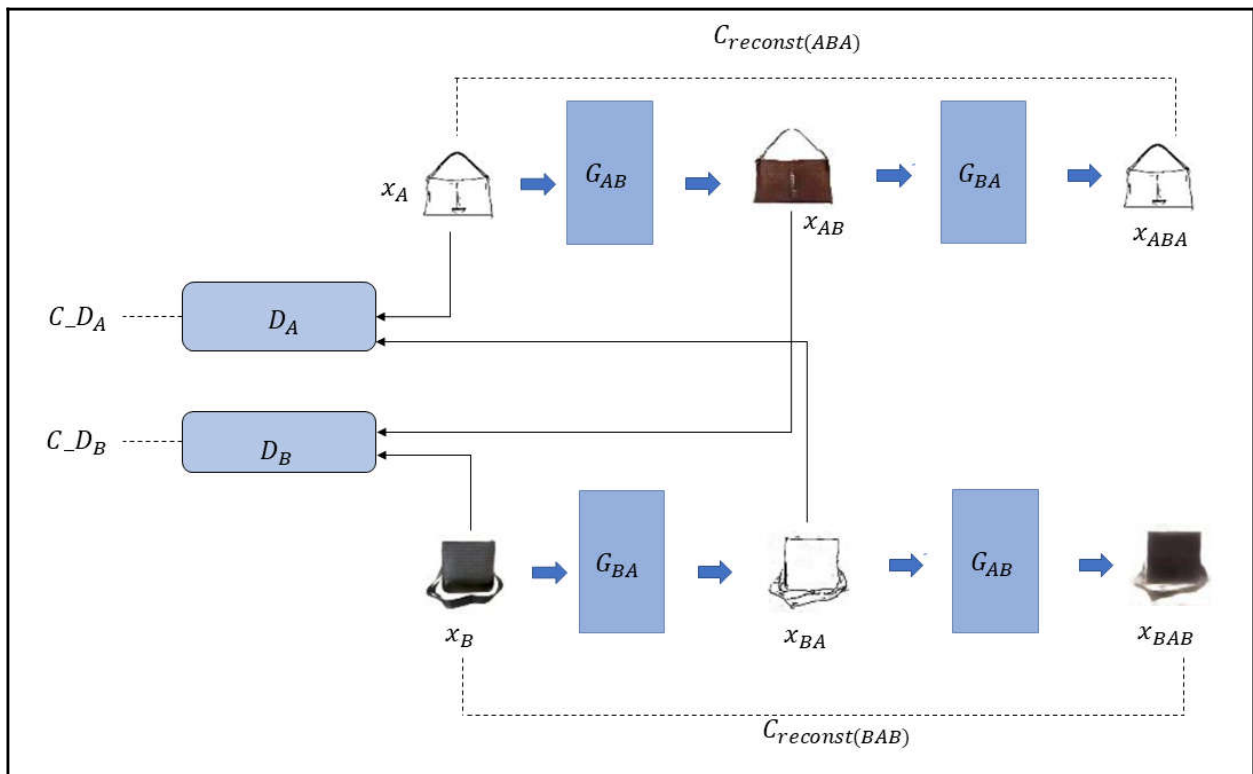

TensorBoard

0.0.0.0:6006

SCALARS IMAGES AUDIO GRAPHS DISTRIBUTIONS HISTOGRAMS EMBEDDINGS

Write a regex to create a tag group X

Show data download links

Ignore outliers in chart scaling

Tooltip sorting method: default

Smoothing 0.6

Horizontal Axis STEP RELATIVE WALL

- d_loss
- da_loss
- da_loss_fake
- da_loss_real
- db_loss
- db_loss_fake
- db_loss_real
- g_loss
- g_loss_a2b
- g_loss_b2a

Runs

da_loss_real

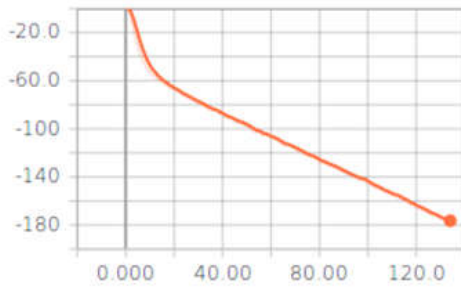

da_loss_fake

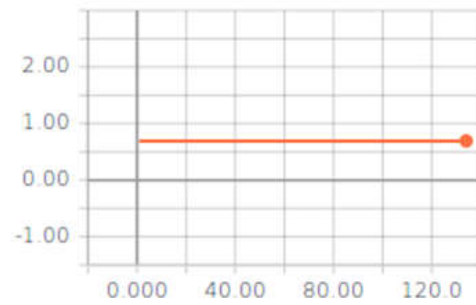

da_loss

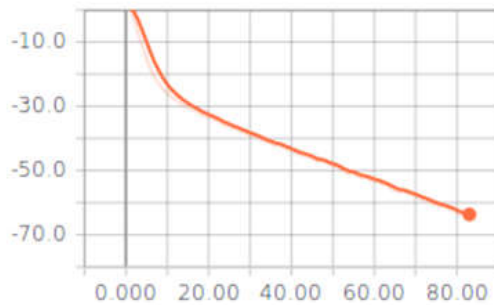

g_loss_a2b

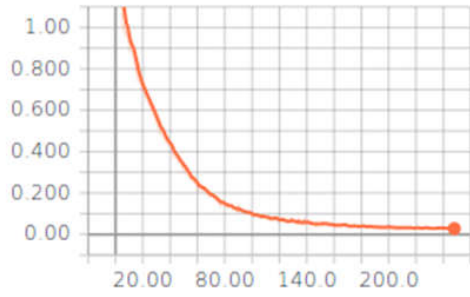

g_loss_b2a

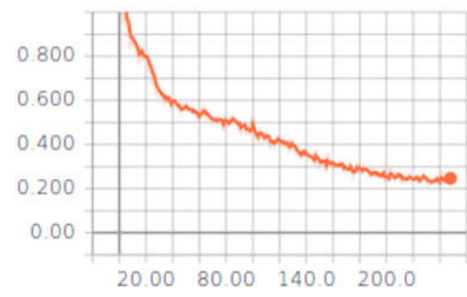

g_loss

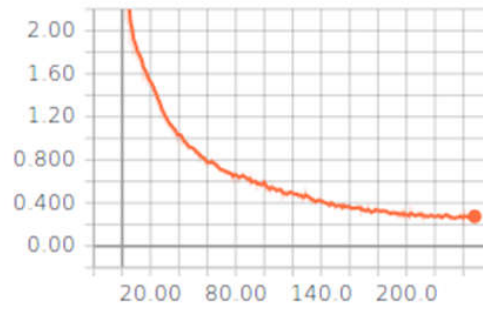

Generated Images of Natural Looking Hand Bag (Domain B)



Epoch 10



Epoch 100



Epoch 199

Generated Images of Hand Bag Sketches (Domain A)



Epoch 10



Epoch 100



Epoch 199

Chapter 5: Video Captioning Application

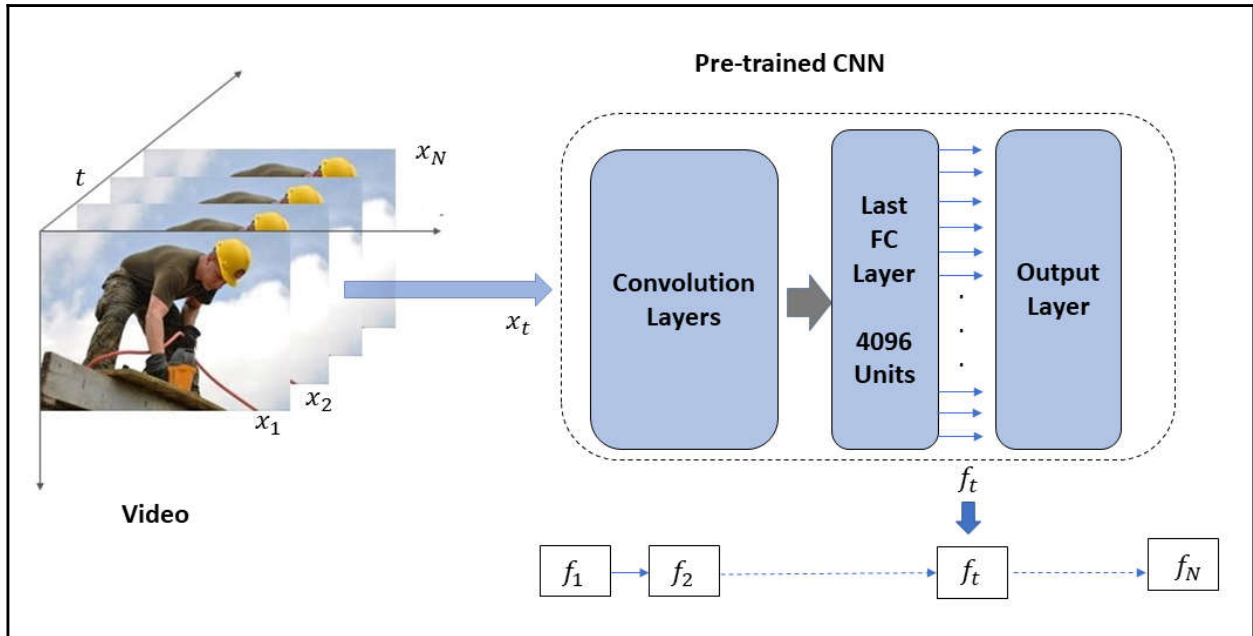

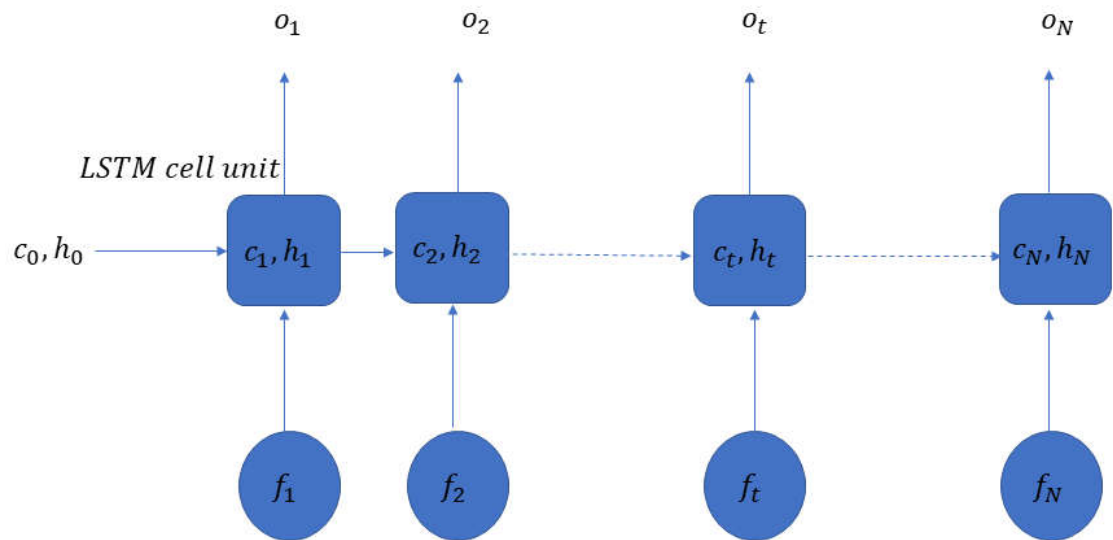

$f_1, f_2, \dots, f_t, \dots, f_N$: CNN features of the sequential image frames of the video
 $o_1, o_2, \dots, o_t, \dots, o_N$: Sequentially generated Output Text
 c_t, h_t : Cell State and Hidden state of the LSTM at timestep t

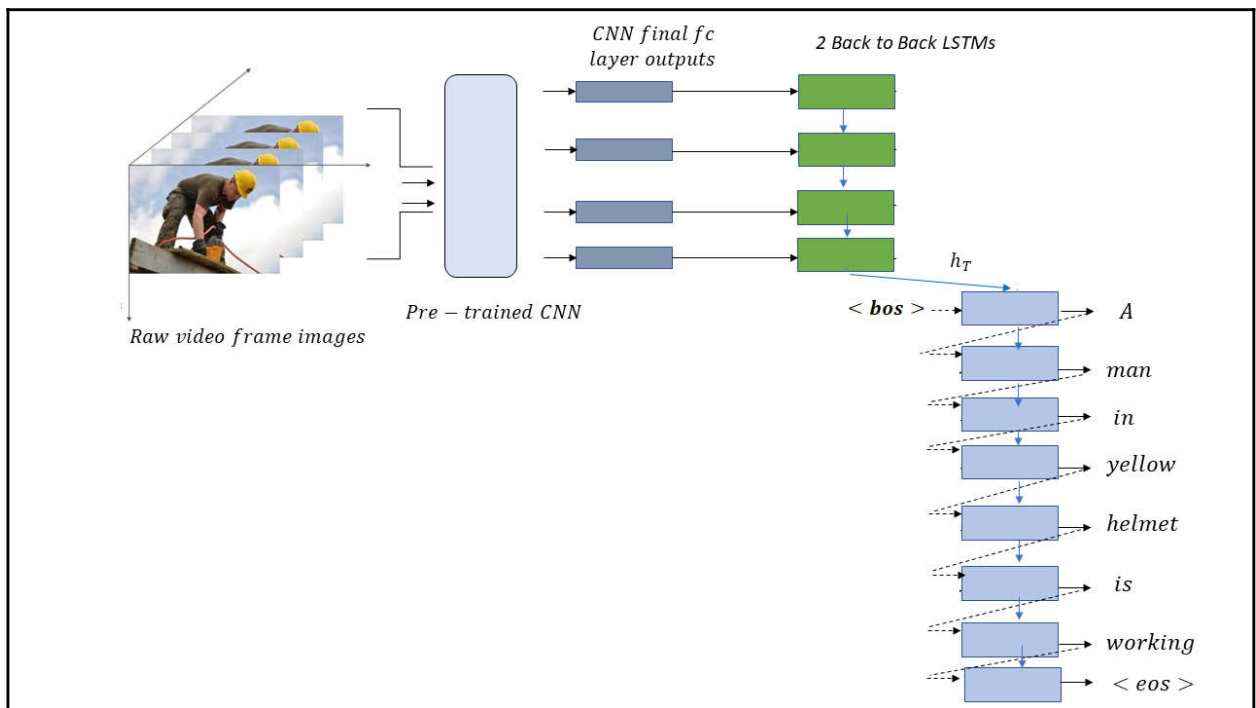
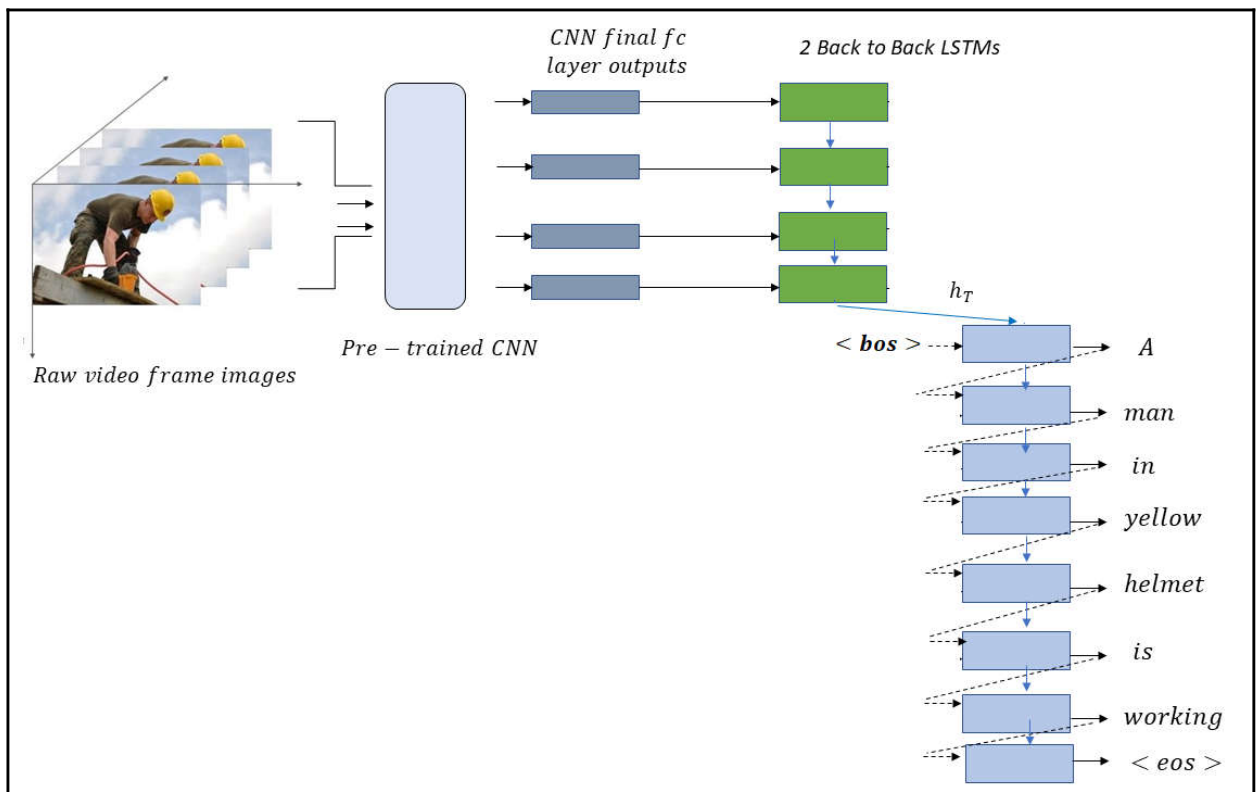

	A	B	C	D	E	F	G	
1	VideoID	Start	End	WorkerID	Source	AnnotationTime	Language	Description
2								
3	mv89psg6zh4	33	46	588702	unverified	55	Slovene	Papagaj se umiva pod tekočo vodo v ljjaku.
4								
5	mv89psg6zh4	33	46	588702	unverified	37	Slovene	Papagaj se umiva pod tekočo vodo v ljjaku.
6								
7	mv89psg6zh4	33	46	362812	unverified	11	Macedonian	папагал се бања
8								
9	mv89psg6zh4	33	46	968828	unverified	84	German	Ein Wellensittich duscht unter einem Wasserhahn.
10								
11	mv89psg6zh4	33	46	203142	unverified	14	Romanian	o pasare sta intr-o chiuveta.
12								
13	mv89psg6zh4	33	46	984231	unverified	35	Romanian	Un papagal se spala intr-o chiuveta.
14								
15	mv89psg6zh4	33	46	130914	unverified	24	Georgian	თუთიყურში რაკონიანში სველდება
16								
17	mv89psg6zh4	33	46	130914	unverified	19	Georgian	თუთიყურში სველდება რაკონიანში
18								
19	mv89psg6zh4	33	46	400189	unverified	23	Serbian	Papagaj se tušira u sudoperu.
20								
21	mv89psg6zh4	33	46	589431	unverified	66	Serbian	Papagaj biva kvašen u sudoperi vodom koja curi iz česme.
22								
23	mv89psg6zh4	33	46	767031	unverified	31	Serbian	Papagaj se tušira u sudoperi.
24								
25	mv89psg6zh4	33	46	649244	unverified	19	Serbian	Papagaj pije vodu u sudoperu
26								
27	mv89psg6zh4	33	46	180998	unverified	19	French	Un oiseau boit.
28								
29	mv89psg6zh4	33	46	197912	unverified	18	Gujarati	કબુતર નાળ નીચે નહાઇ છે
30								
31	mv89psg6zh4	33	46	339861	unverified	52	Hindi	एक तोता नहा रहा है.
32								
33	mv89psg6zh4	33	46	818922	unverified	253	Hindi	बेसन वश में कुछ पड़ा है.
34								
35	mv89psg6zh4	33	46	161492	unverified	34	Hindi	तोता नहातअ हे
36								
37	mv89psg6zh4	33	46	797651	unverified	27	Hindi	थूथ नहा रहा हे
38								
39	mv89psg6zh4	33	46	682611	clean	66	English	A bird in a sink keeps getting under the running water from a faucet.
40								
41	mv89psg6zh4	33	46	760882	clean	16	English	A bird is bathing in a sink.
42								
43	mv89psg6zh4	33	46	878566	clean	76	English	A bird is splashing around under a running faucet.

index	VideoID	Start	End	WorkerID	Source	AnnotationTime	Language	Description
77153	krAk8WPZRL4	207	212	281652	unverified	33	English	A car has blasted behind the people standing.
119339	lxw6wmoC_xg	116	126	280252	clean	75	English	A woman is putting a small baby in a water pip.
33060	SULWQEAERk*	13	26	919506	unverified	73	English	tortoise walking on grass
118294	1qV4wYTYlo	151	164	948158	unverified	53	English	A cat fished a straw out of its water bowl.
35337	zHy7pM0U49w	110	116	947723	unverified	19	English	A man is chopping a tomato.
28824	bkazguPsusc	74	85	481414	clean	125	English	A cat is crawling underneath a couch.
16701	6t0BpjwYKco	71	76	829808	unverified	29	English	A lady is cutting an apple.
62353	aM-RcQJ0a7l	37	55	762891	clean	30	English	The man is frying food.
40211	FCjpuJaUec0	19	26	297776	unverified	69	English	A cat plays in a toilet.
13565	ngHDYzhDBk4	5	14	762891	clean	21	English	The girls are dancing.
77485	xxHx6s_DbUo	57	61	707318	clean	11	English	A man is doing pull ups.
31845	lFqogTmAvQ	240	246	762891	clean	14	English	The man and woman are riding a motorcycle.
62473	lfr05K_vKM	55	65	275759	clean	37	English	A man showing a gun packed in a box.
72911	dJcIOz32dnw	40	60	707318	unverified	16	English	A man pulls eggs out of his pants.
23996	FHwC2THZJfA	0	10	283974	unverified	106	English	Loris try to climb a rope
96143	lmcrlZeob4w	23	26	807741	unverified	42	English	Christmas in Japan
65195	ejwQqCHNIE	7	12	688049	unverified	167	English	Love song is sing by lovers
36558	98Airq4pFXs	148	153	135621	clean	88	English	Two black men are kick boxing.
121514	BVjvRpmHq0w	231	250	833861	unverified	207	English	The two woman's are preparing the food
82325	QTAqSbMkXU	65	75	772960	clean	509	English	Two portions of salmon flesh are placed in a dish containing salt and whole spices and a baking sheet is spread over them.
117678	LwicalvS0	90	104	181773	clean	37	English	A man is pouring sugar into his coffee.
58604	l_Nb_oRxpM	1	15	772960	clean	309	English	An old man is swinging his hip with his hands placed thereon as he bends sideways standing on a pavement.
14936	L9wD3kw-8FE	65	73	553931	unverified	19	English	Someone chopped a log with a machete.
25574	J---alyznGQ	0	6	275759	clean	96	English	A cat is playing a piano.
44267	KUc1cWKXJdc	20	30	313410	unverified	57	English	Two small yellow ducks run around together in a yard.
110418	JktNQnQLblQ	4	9	418656	unverified	224	English	A woman is roasting the bread.
80187	ecm9gt2Pgkc	1	24	825347	clean	12	English	A woman is playing with a rabbit.
42987	3eqFFRSXwGE	84	96	159786	clean	1206	English	Two dogs are playing on a floor.
49600	DItoA1dDwGQ	32	42	373663	clean	28	English	A woman is riding on an elephant.
77537	ZvJvNcukZ4w	0	10	155632	clean	46	English	A badger attacks a fox.
66208	ObBss94n3gl	35	46	130040	unverified	68	English	A man slicing some vegetables
60005	9gbUM9oHBNl	557	563	303815	unverified	42	English	the person is drinking the water
15985	-7KMZQEsJW4	205	208	371782	unverified	136	English	A guy is holding the sunflower in his hand.
64925	AzMltkXGJK	0	10	707318	unverified	20	English	A boy is looking outside a window.
34205	H1Bok7Dg7g8	21	26	373663	unverified	129	English	A puppet is talking on a phone
89675	VLBsAPZ2DDE	58	64	922727	clean	25	English	Chickens are chasing a little boy.
51448	lTA0rWPE4nY	17	23	869926	unverified	19	English	A man is washing his hands in the bathroom.
5318	vE1qvaM3lAs	39	46	467982	unverified	119	English	A man removing scratches from a dvd with some sort of chemicals.
31732	mUMTFnQWab	1	9	696912	unverified	92	English	The girl is riding a horse around the fence.
86781	ldfROA_BXjw	441	448	762891	clean	18	English	The man is seasoning dough.
5253	32_A0-er4Ws	16	20	534192	unverified	28	English	A woman picks a tomato outdoors.
81648	hM3jzyNlpc	0	10	309959	clean	16	English	The hamster ran in the wheel.
54243	WP-G-BIwORG4	130	134	707318	clean	16	English	A person is baking food in the oven.

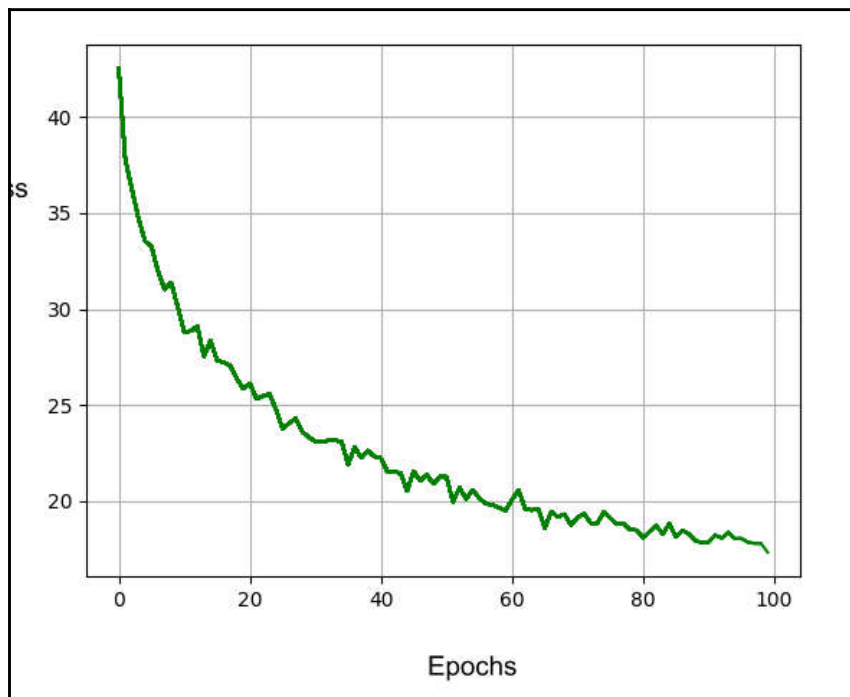

Video frames



Generated Caption : a woman is mixing eggs into a bowl

Video Frames



Generated Caption : man is putting a lid on a sink

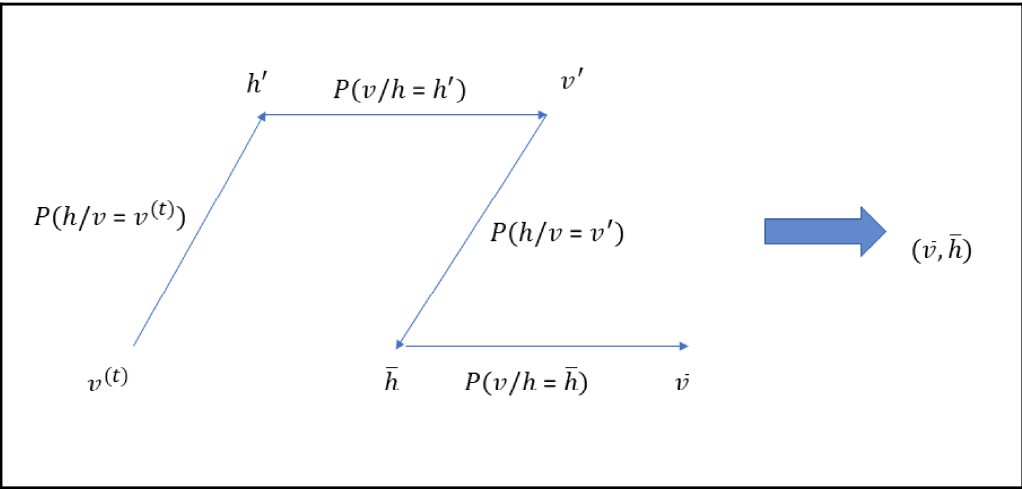

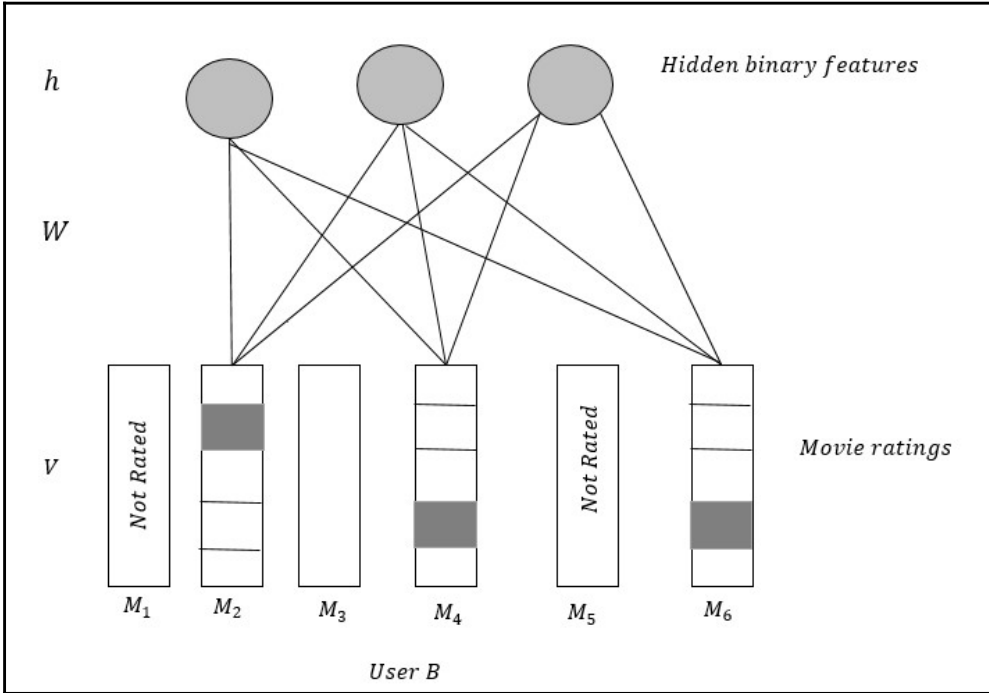
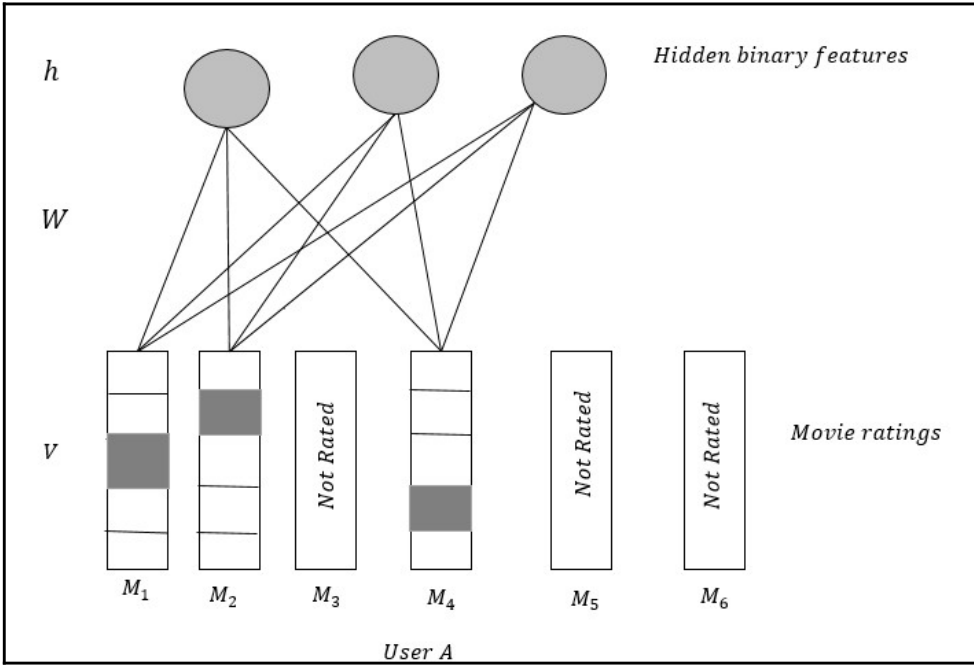

Chapter 6: Conversational AI Chatbots for Customer Service

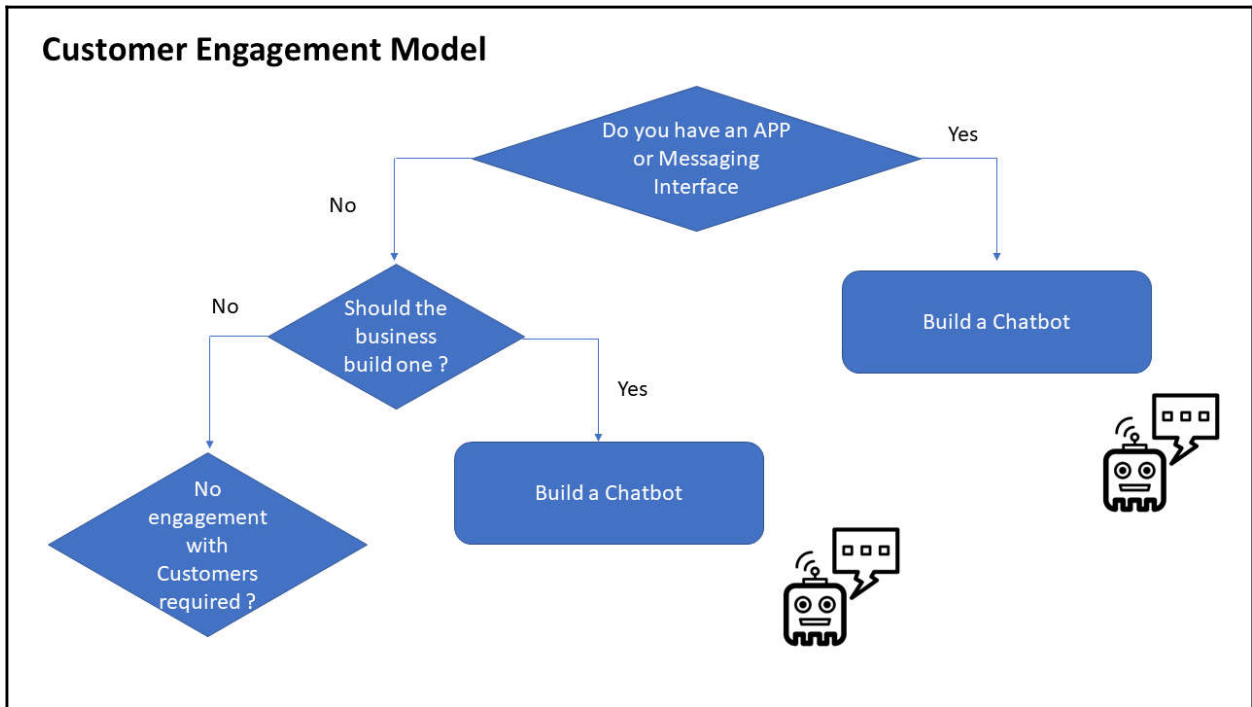

Chapter 7: Mobile App for Movie Review Sentiment Analysis

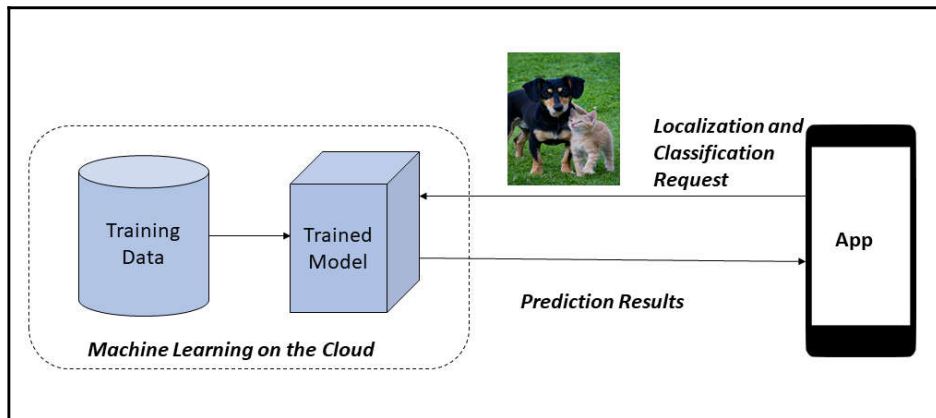

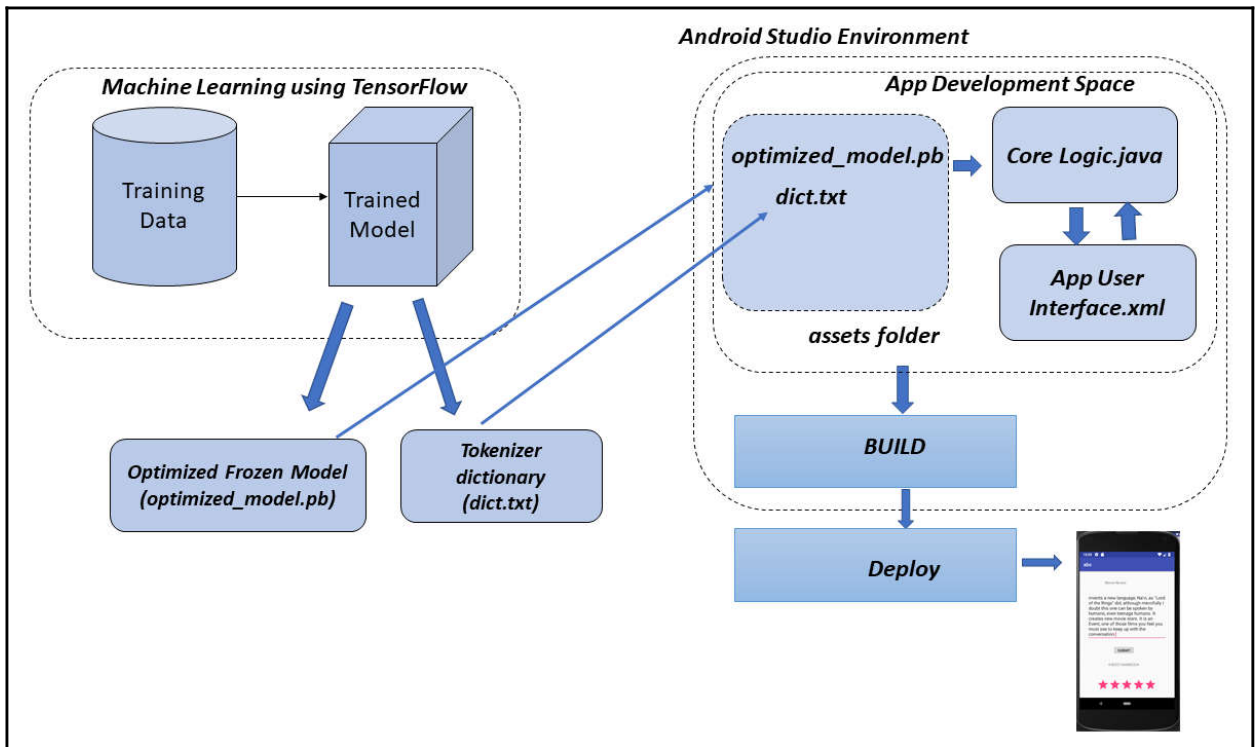

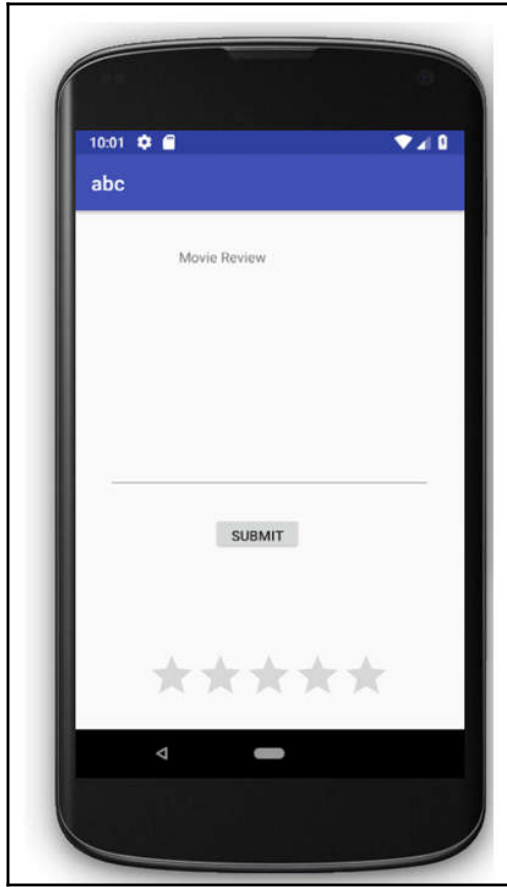

Review and Rating provided by the Reviewer

AVATAR

★★★★★ | Roger Ebert

December 11, 2009 | 66

Watching "Avatar," I felt sort of the same as when I saw "Star Wars" in 1977. That was another movie I walked into with uncertain expectations. [James Cameron's](#) film has been the subject of relentlessly dubious advance buzz, just as his "Titanic" was. Once again, he has silenced the doubters by simply delivering an extraordinary film. There is still at least one man in Hollywood who knows how to spend \$250 million, or was it \$300 million, wisely.

"Avatar" is not simply a sensational entertainment, although it is that. It's a technical breakthrough. It has a flat-out Green and anti-war message. It is predestined to launch a cult. It contains such visual detailing that it would reward repeating viewings. It invents a new language, Na'vi, as "Lord of the Rings" did, although mercifully I doubt this one can be spoken by humans, even teenage humans. It creates new movie stars. It is an Event, one of those films you feel you must see to keep up with the conversation.

Print Page

Like 4

G+

Tweet

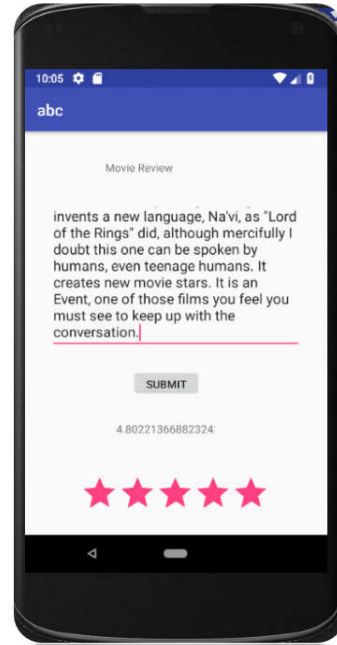

Review and Rating in the rottentomatoes.com site

TOMATOMETER 71% Average Rating: 7/10 Reviews Counted: 328 Fresh: 233 Rotten: 95	All Critics Top Critics Critic Consensus: <i>Interstellar</i> represents more of the thrilling, thought-provoking, and visually resplendent filmmaking moviegoers have come to expect from writer-director Christopher Nolan, even if its intellectual reach somewhat exceeds its grasp.	AUDIENCE SCORE 85% liked it Average Rating: 4.1/5 User Ratings: 172,755
--	--	---

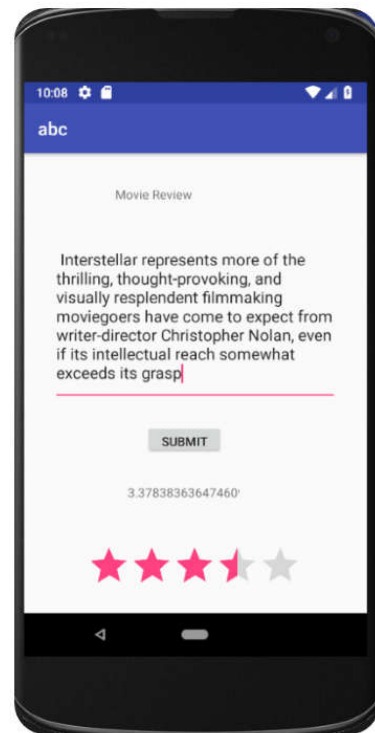

Chapter 8: Conversational AI Chatbots for Customer Service

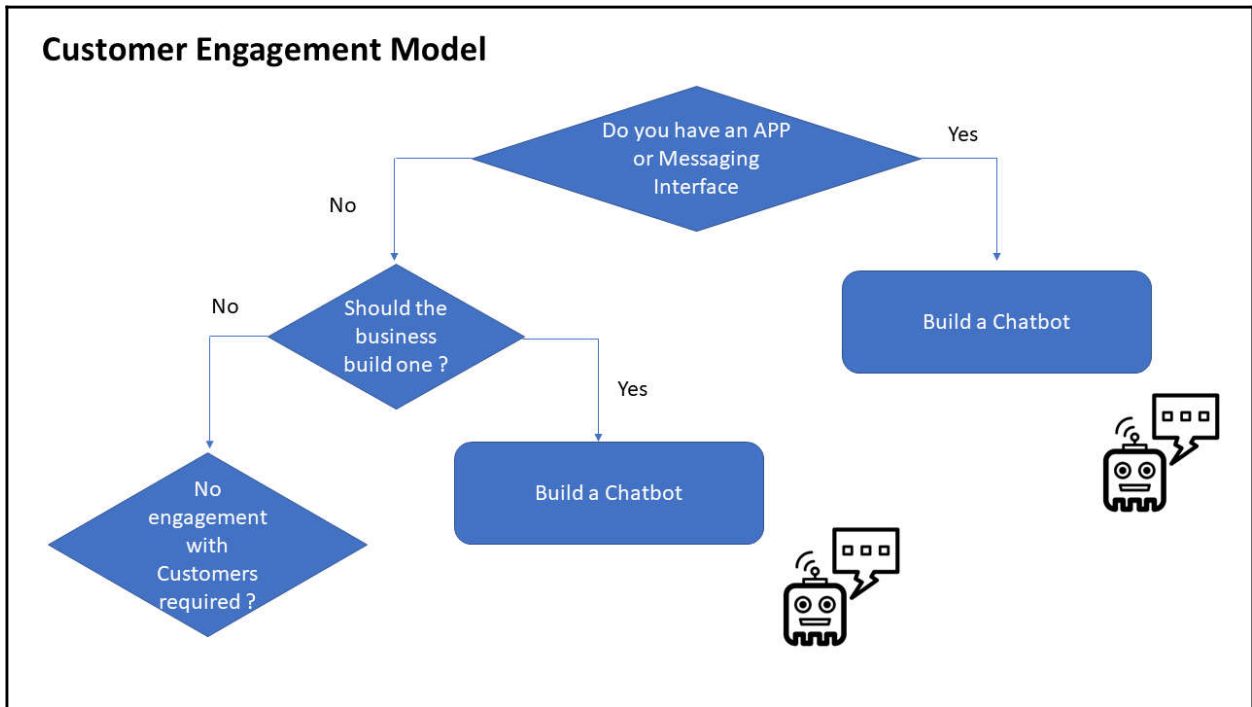

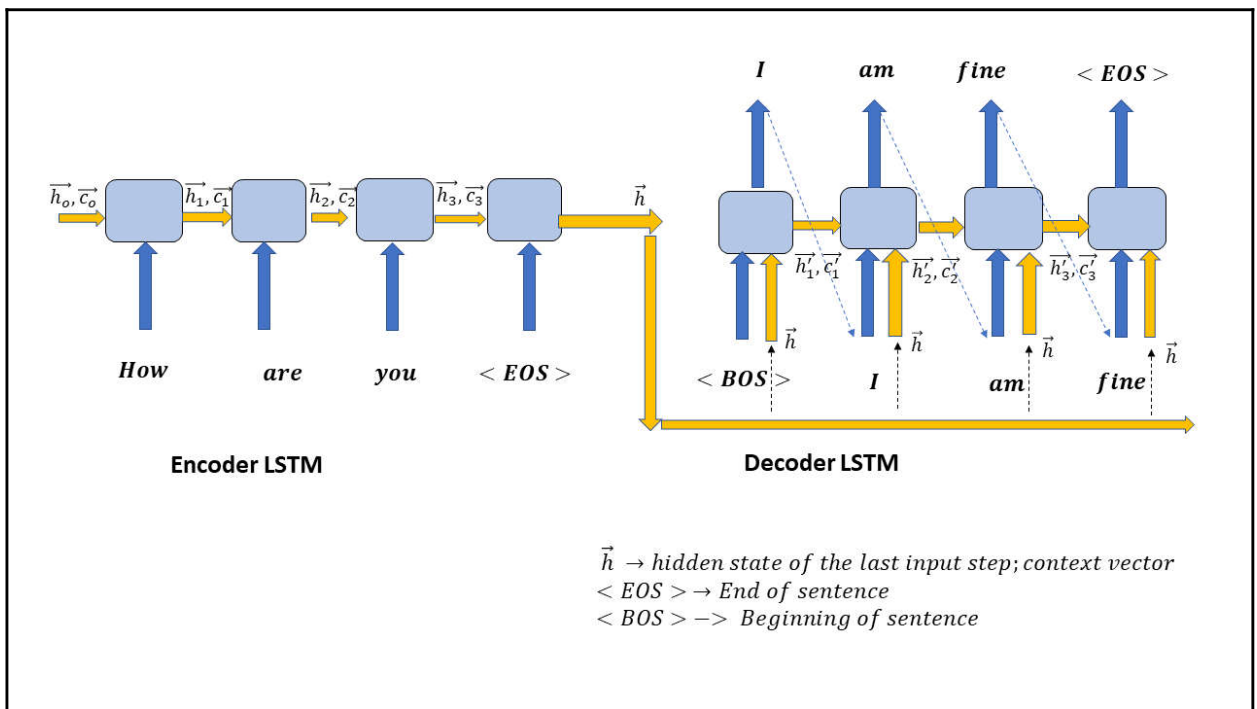
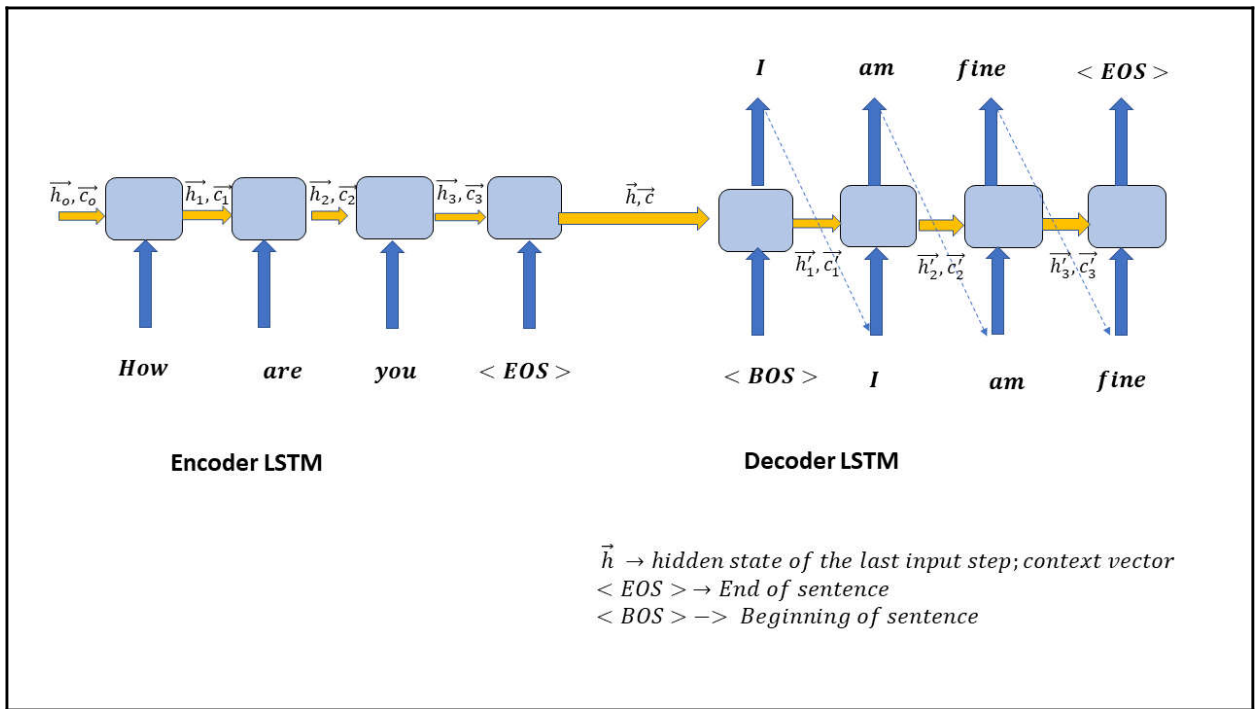

Chapter 9: Autonomous Self-Driving Car Through Reinforcement Learning

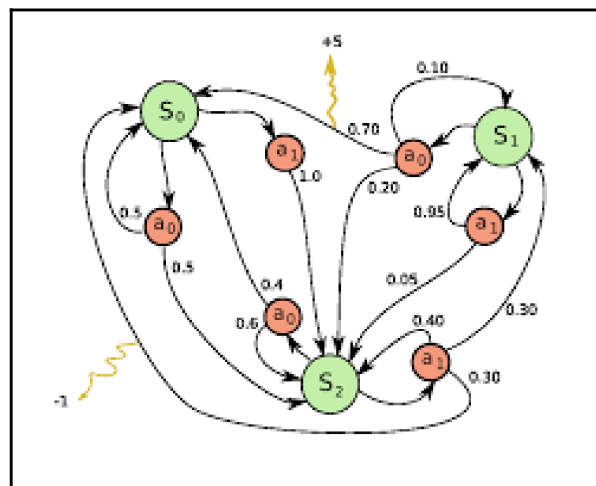
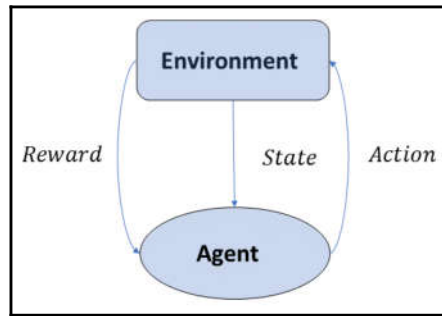

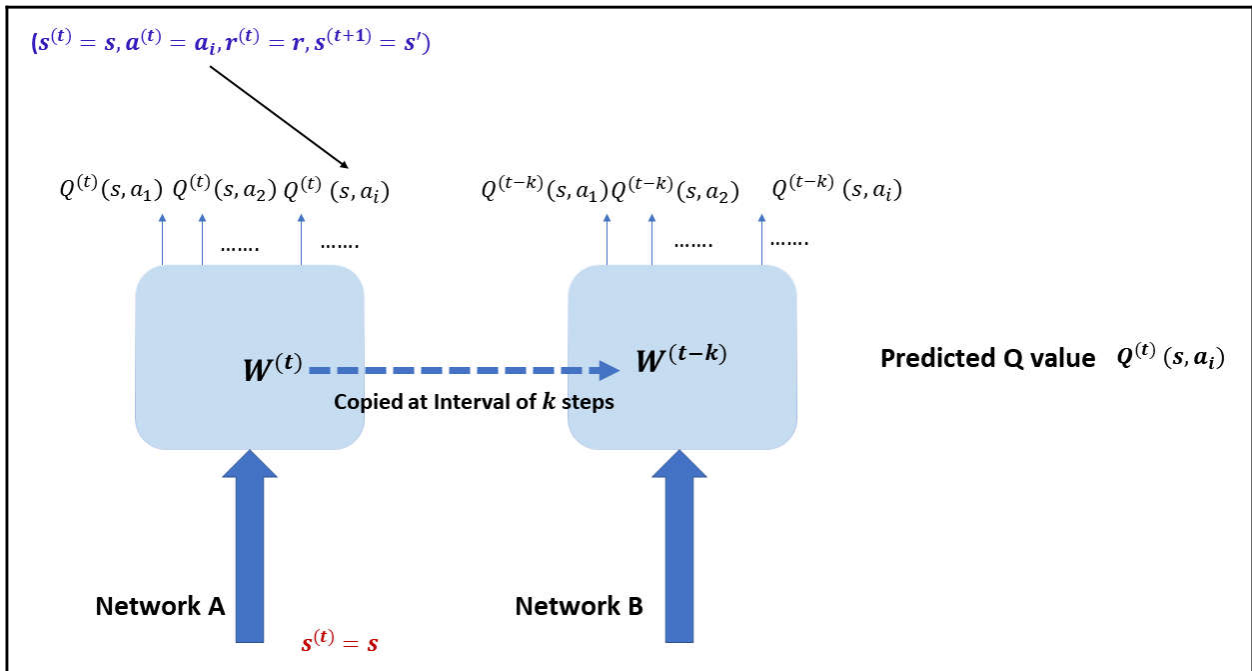
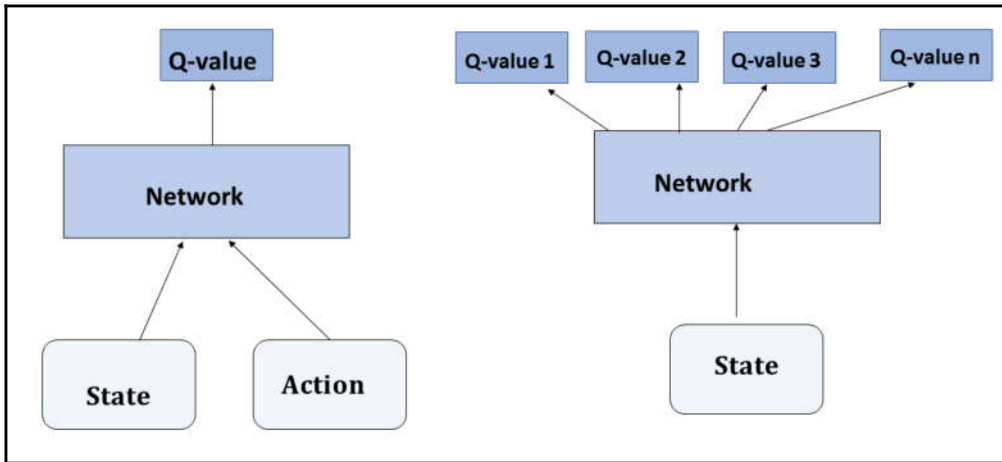

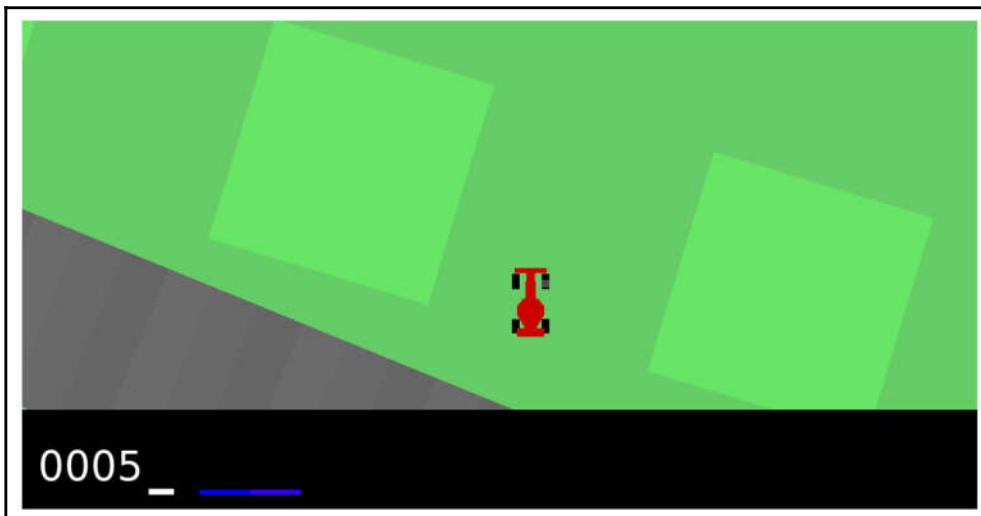
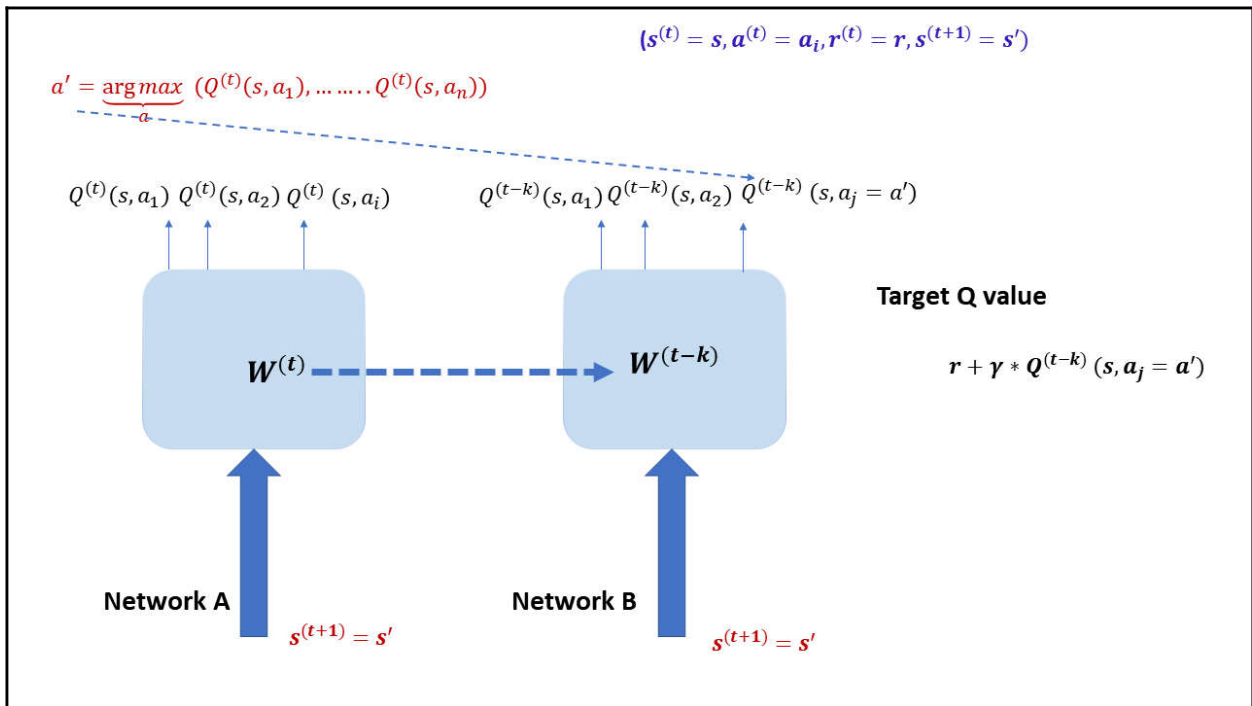

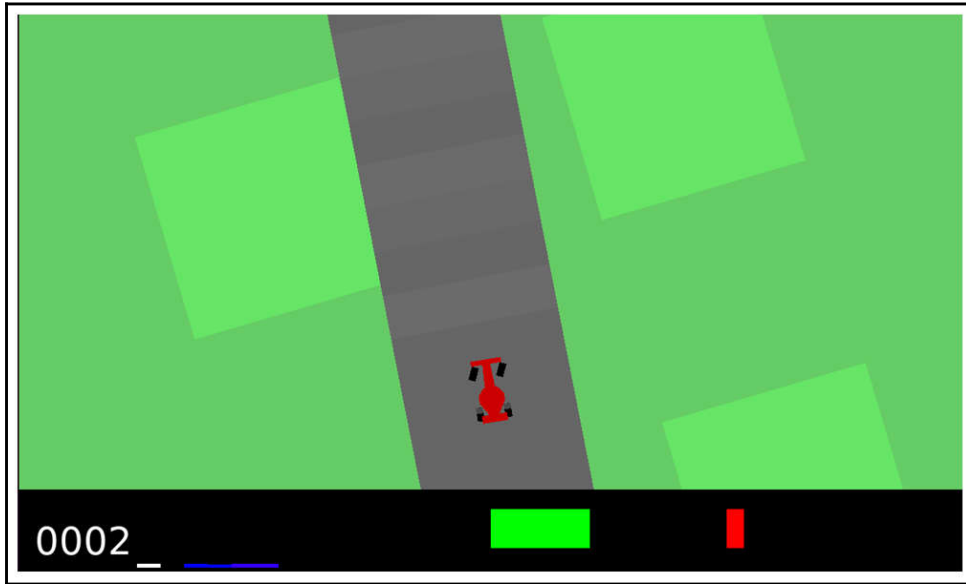

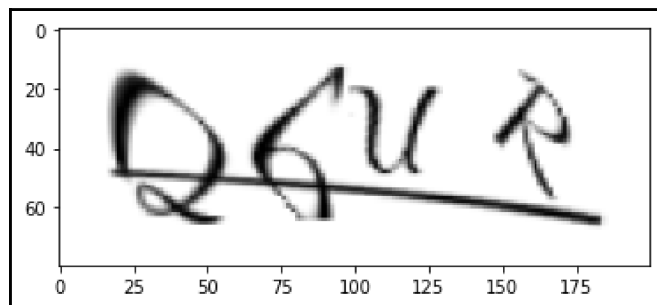

Chapter 10: CAPTCHA from a Deep-Learning Perspective

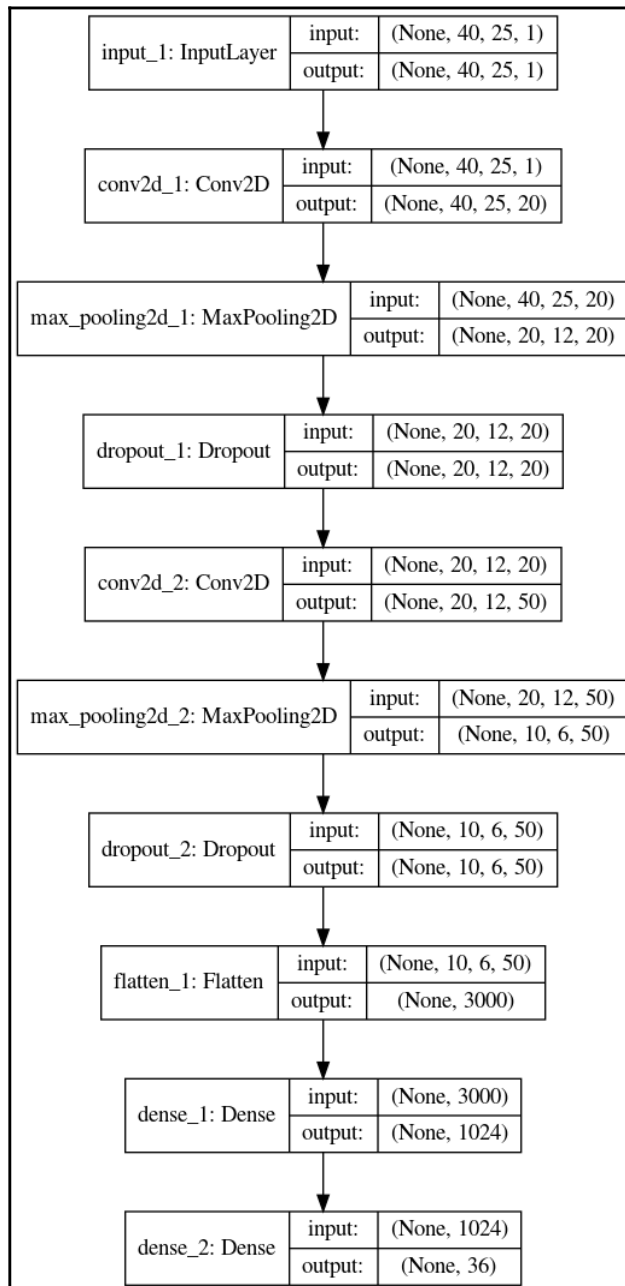

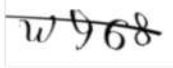
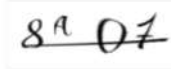

	Prediction	Target
	[M, '3', '6', 'W']	[M, '3', '6', '2']
	[W, 'Y', '6', '8']	[W, '9', '6', '8']
	[8, 'M', '0', '7']	[8, 'A', '0', '7']

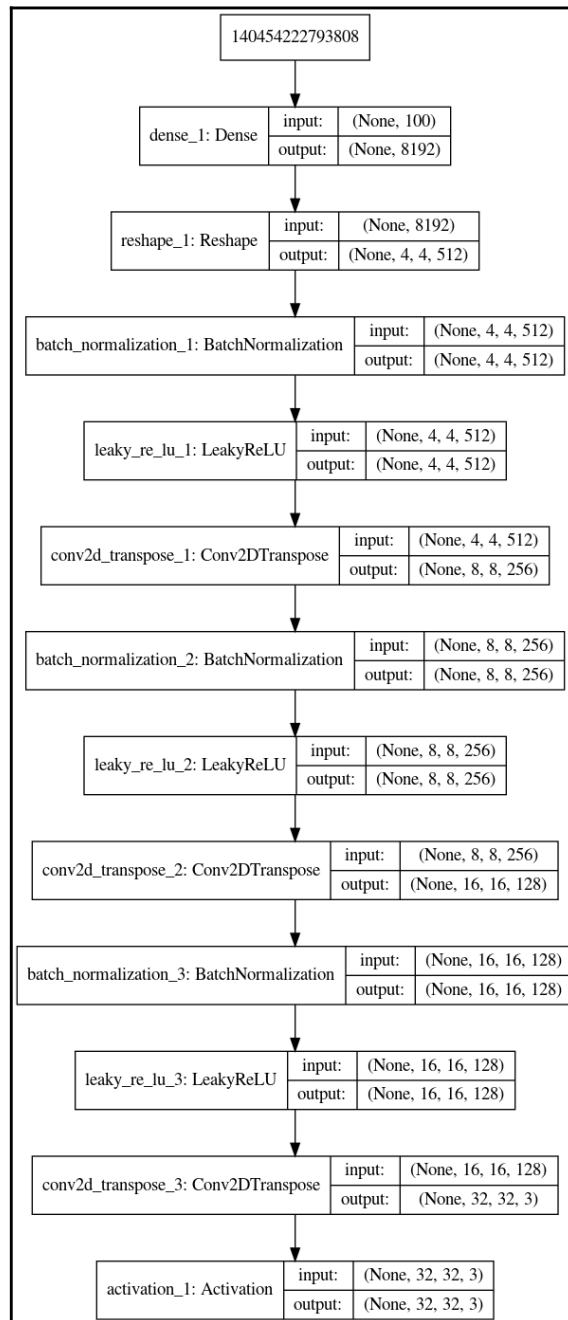

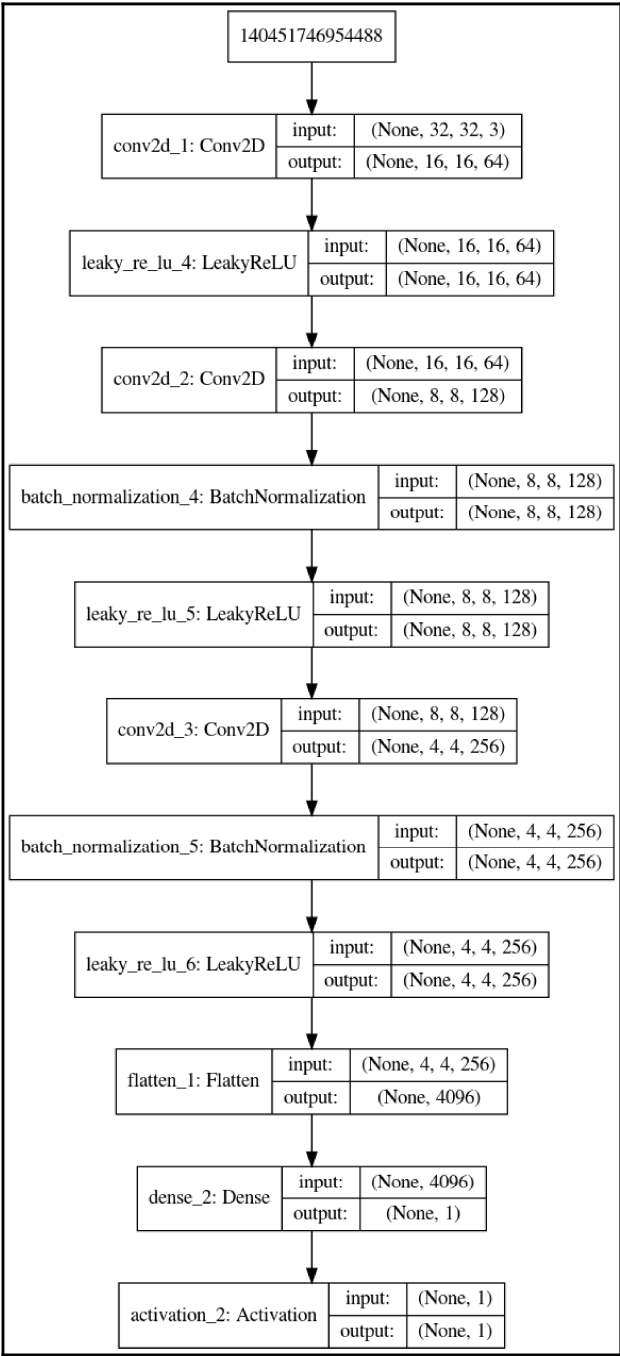



18 11 20 30 15 5 30 30 2 10

22 15 8 2 51 35 84 67 61 122

1 6 12 13 2 12 8 26 30 35

3 9 27 6 13 08 8 7 7 27

5 2 5 108 15 11 6 5 13

2 4 2 20 32 11 4 2 14 8

9

120

100

20

9

31

3

9

2

4

138

35

16

34

5