

Chapter 1: Bayesian Network Fundamentals

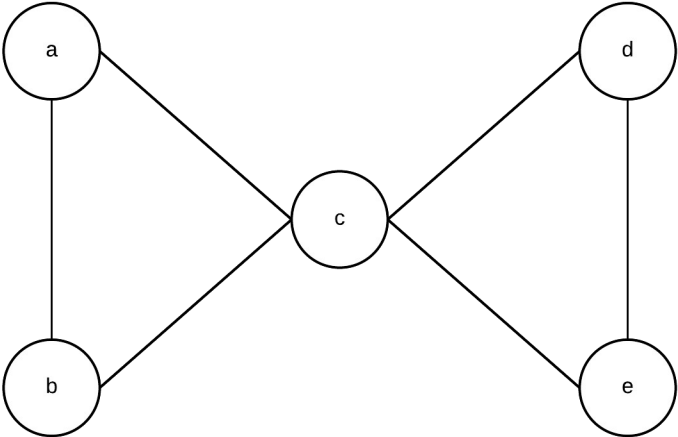

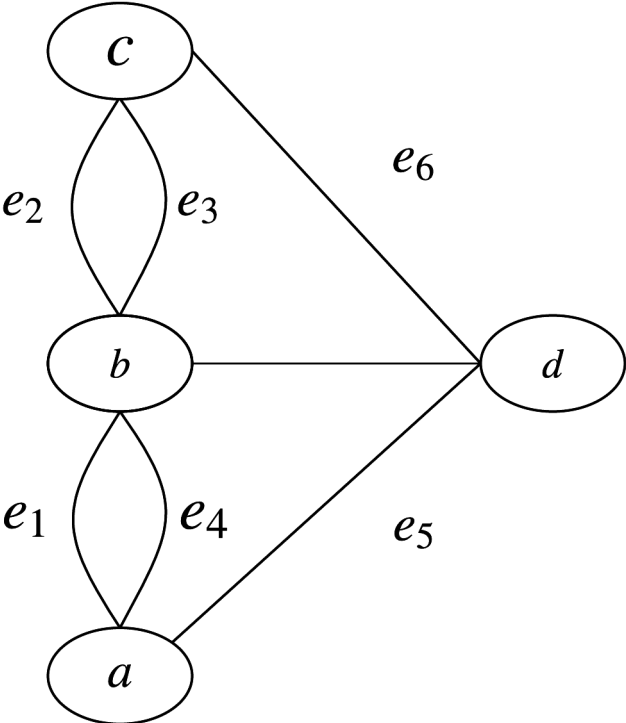

Location	P(L)
Good	0.6
Bad	0.4

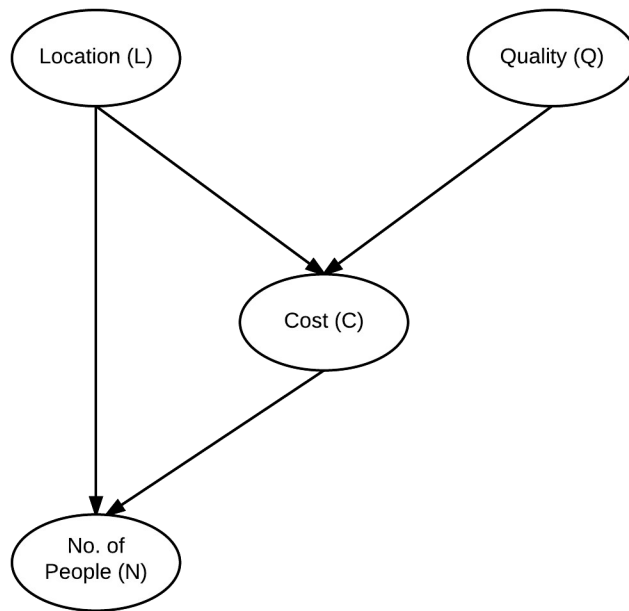
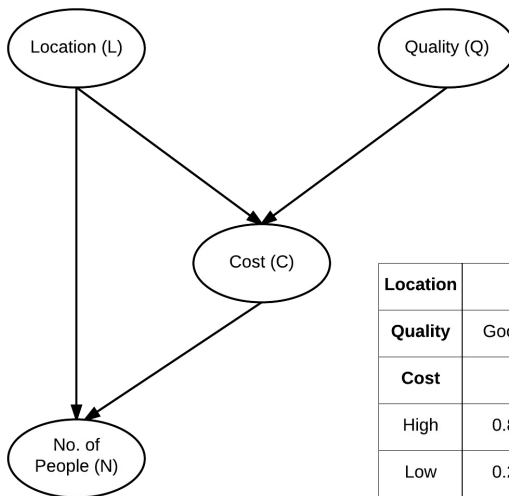

Quality	P(Q)
Good	0.3
Normal	0.5
Bad	0.2

Location	Good			Bad		
	Good	Normal	Bad	Good	Normal	Bad
Cost						
High	0.8	0.6	0.1	0.6	0.6	0.05
Low	0.2	0.4	0.9	0.4	0.4	0.95

Location	Good		Bad	
	High	Low	High	Low
No. of People				
High	0.6	0.8	0.1	0.6
Low	0.4	0.2	0.9	0.4

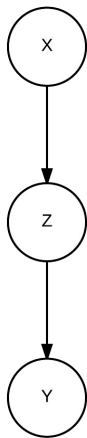
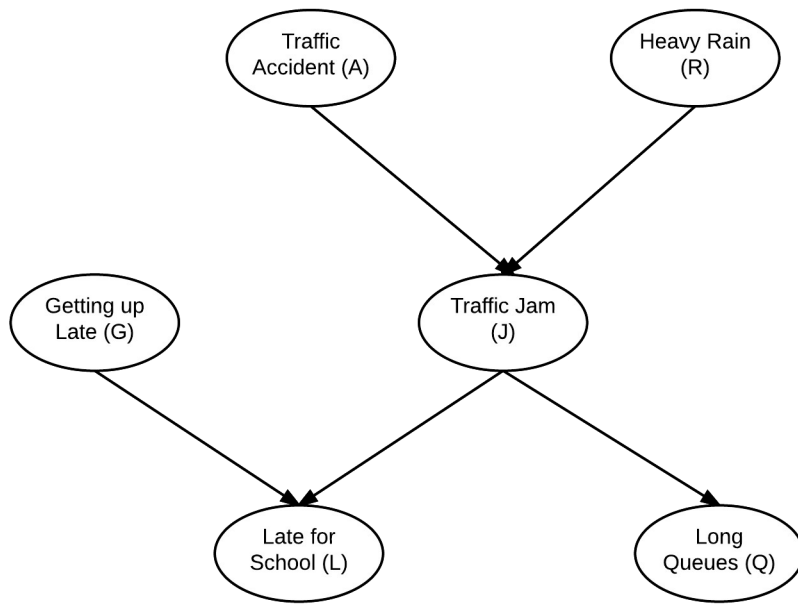

Fig 3(a)

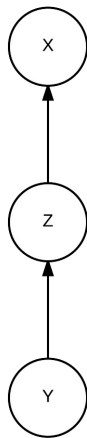

Fig 3(b)

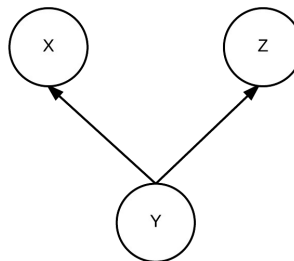

Fig 3(c)

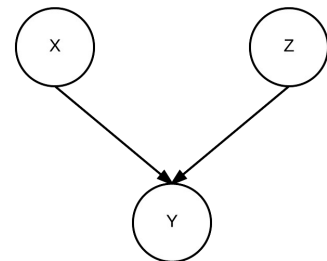
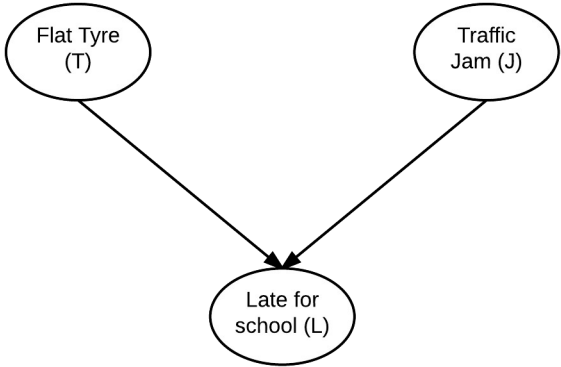
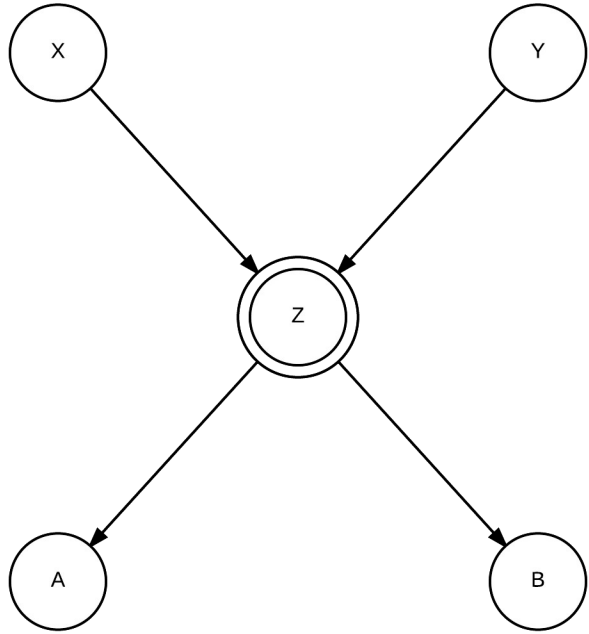
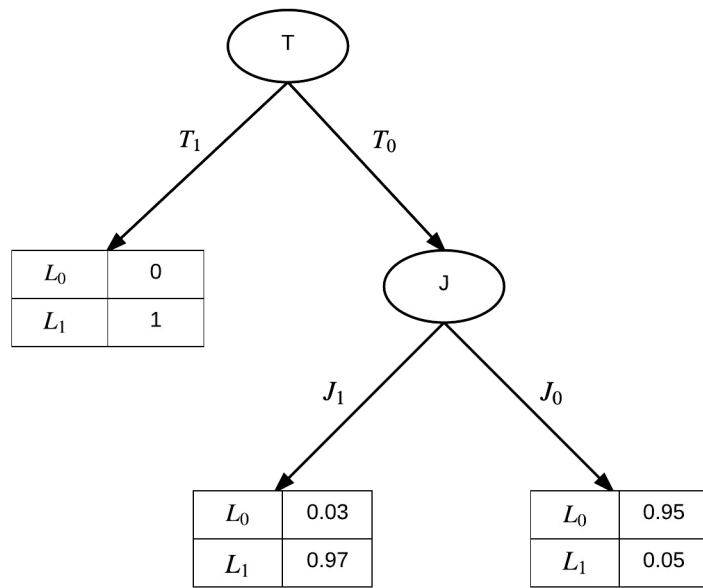

Fig 3(d)





Chapter 2: Markov Network Fundamentals

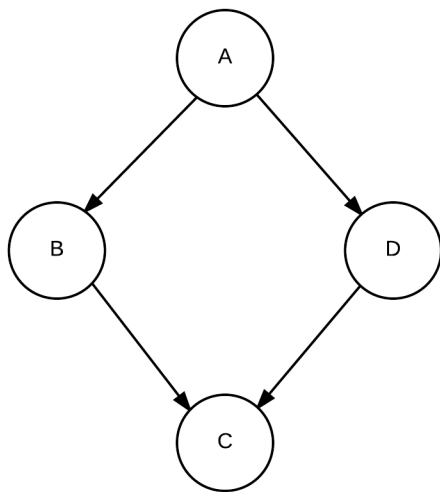

Fig 2.1(a)

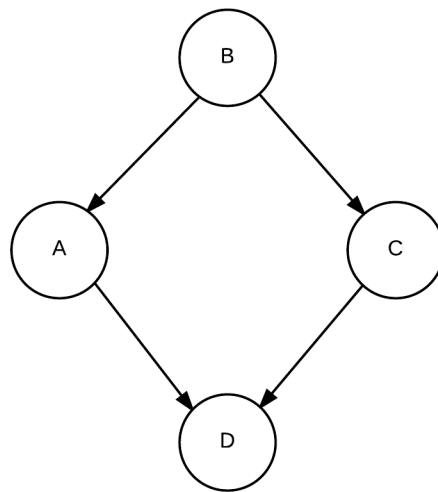

Fig 2.1(b)

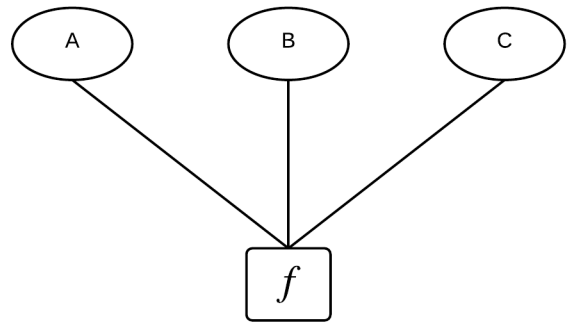
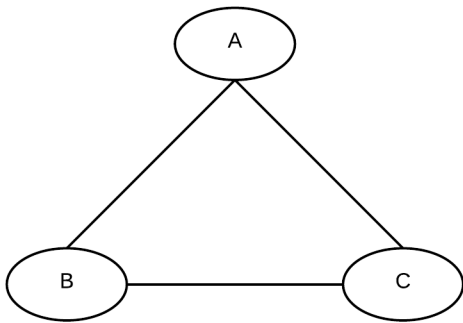
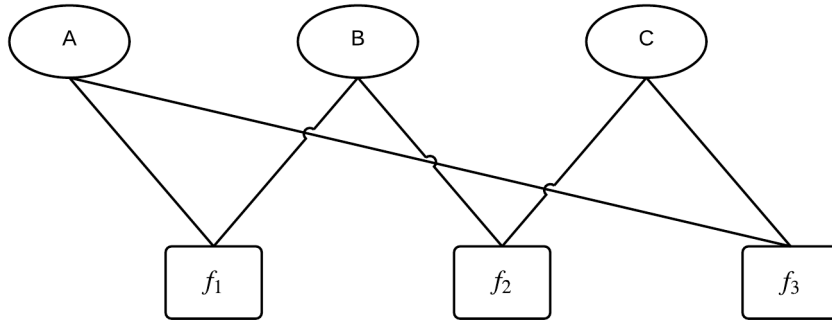
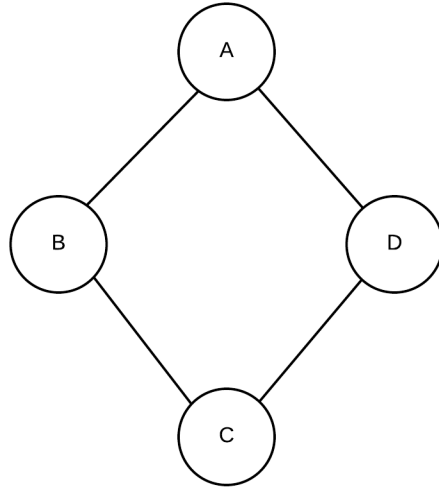
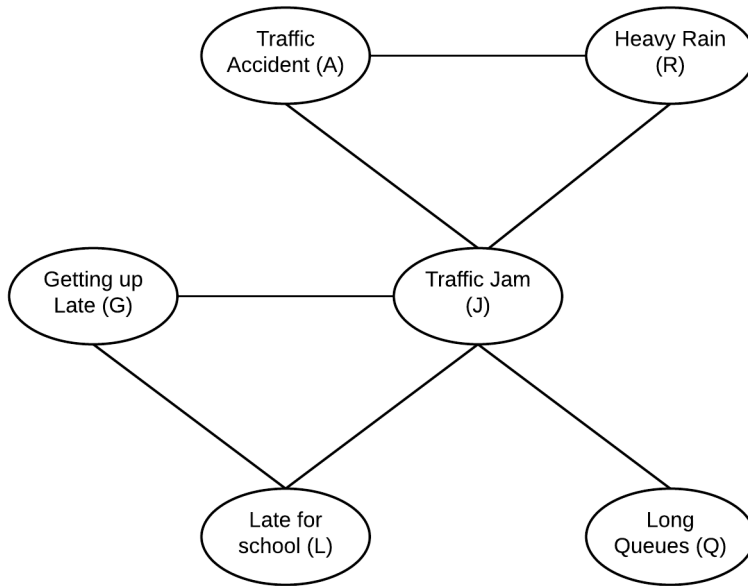
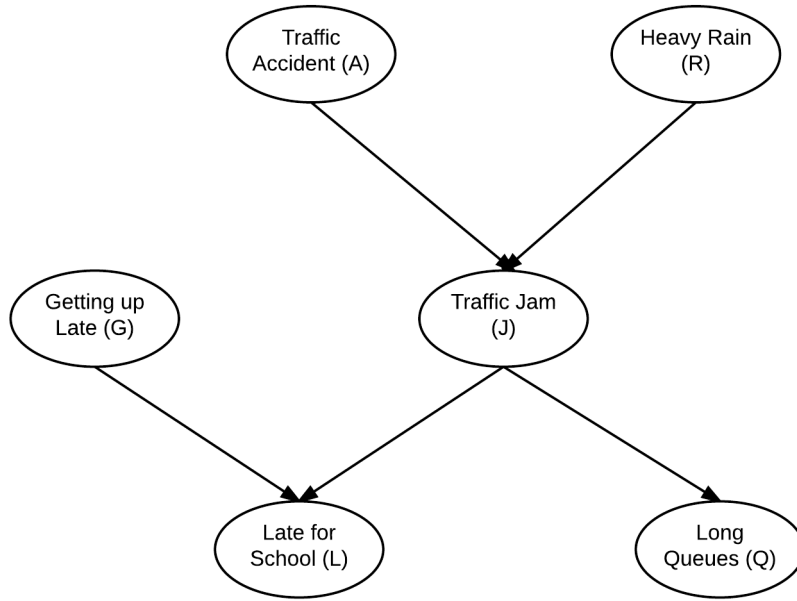

Fig 2.4 (a)

Fig 2.4 (b)



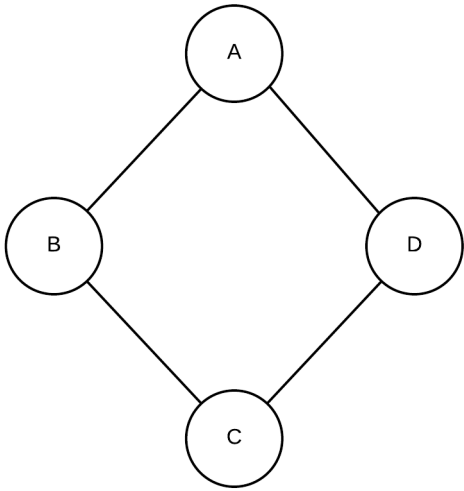

Fig 2.7(a)

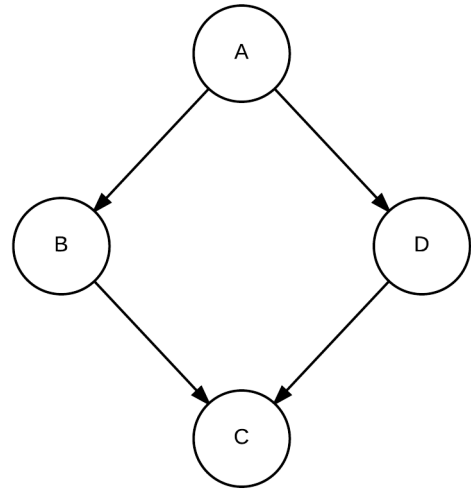

Fig 2.7(b)

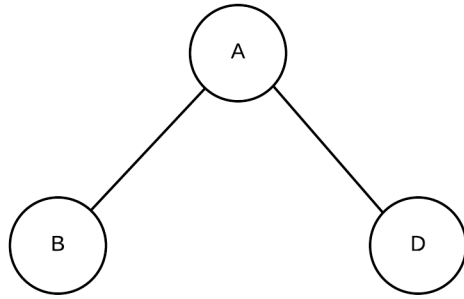

Fig 2.8(a)

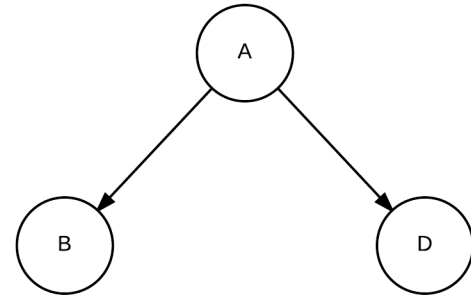
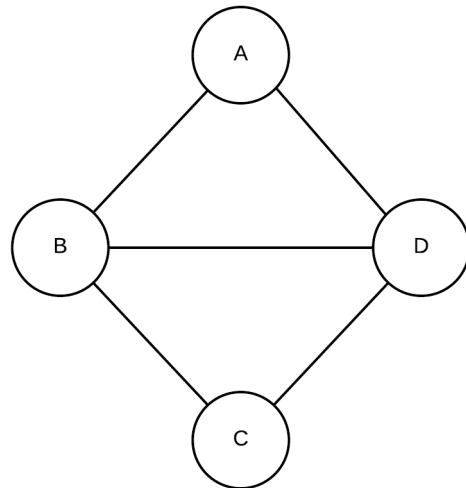
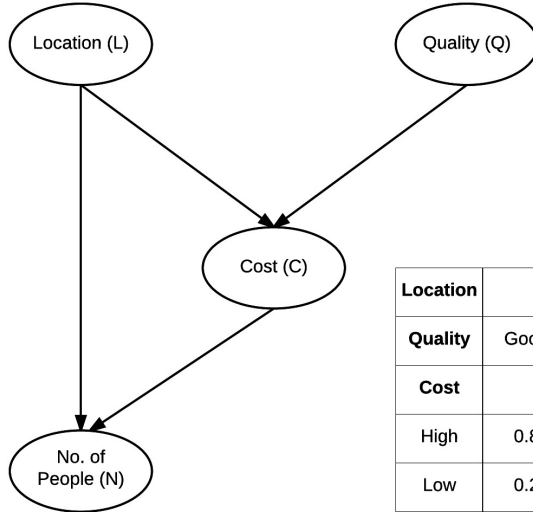

Fig 2.8(b)



Chapter 3: Inference – Asking Questions to Models

Location	P(L)
Good	0.6
Bad	0.4



Quality	P(Q)
Good	0.3
Normal	0.5
Bad	0.2

Location	Good			Bad		
	Good	Normal	Bad	Good	Normal	Bad
Quality						
Cost						
High	0.8	0.6	0.1	0.6	0.6	0.05
Low	0.2	0.4	0.9	0.4	0.4	0.95

Location	Good		Bad	
	High	Low	High	Low
Cost				
No. of People				
High	0.6	0.8	0.1	0.6
Low	0.4	0.2	0.9	0.4

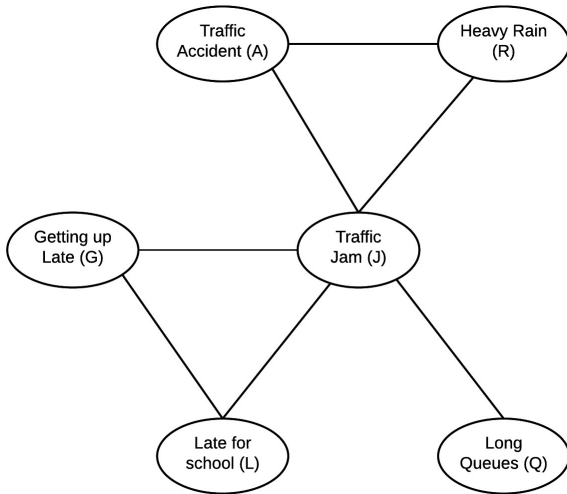

Fig 3.2 (a)

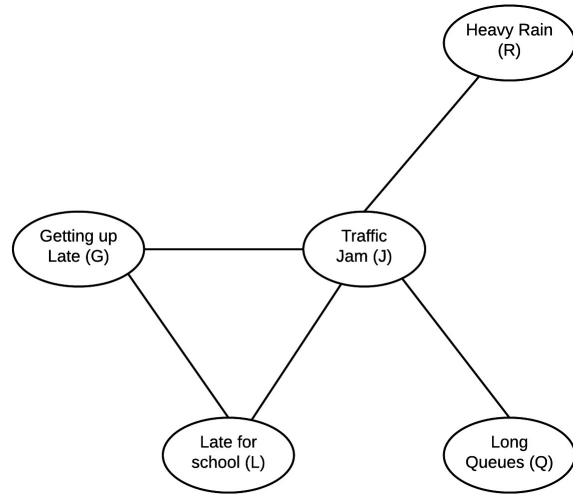

Fig 3.2 (b)

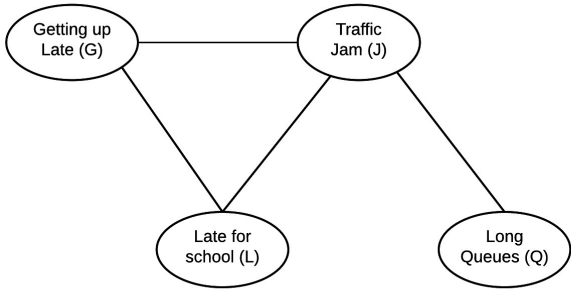

Fig 3.2 (c)

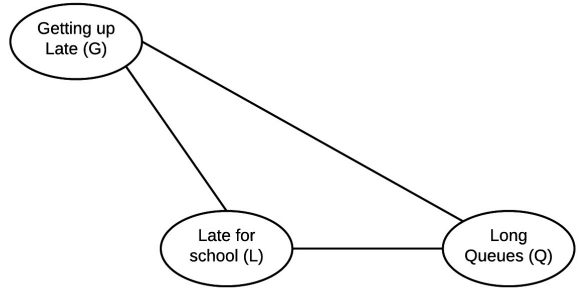

Fig 3.2 (d)

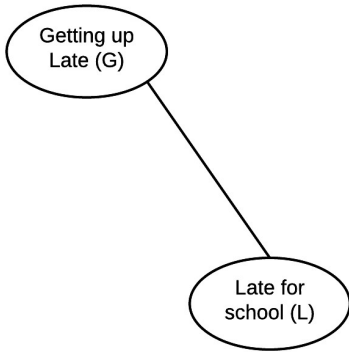
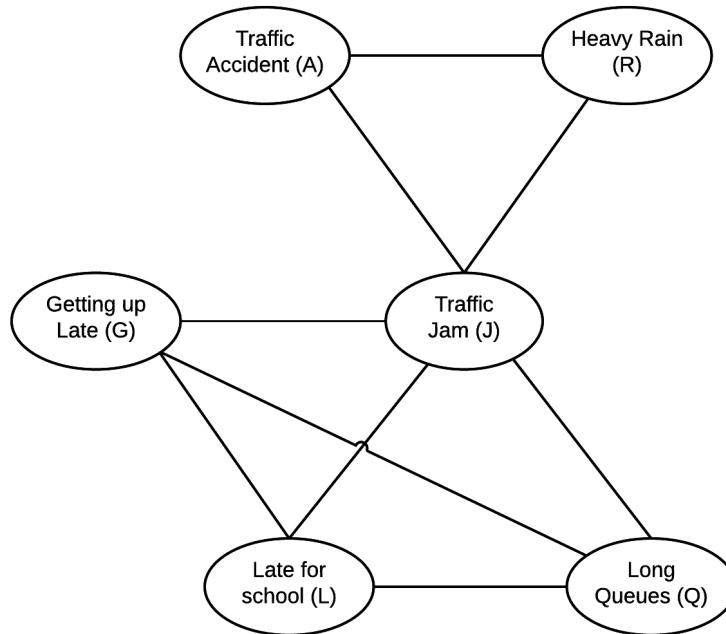
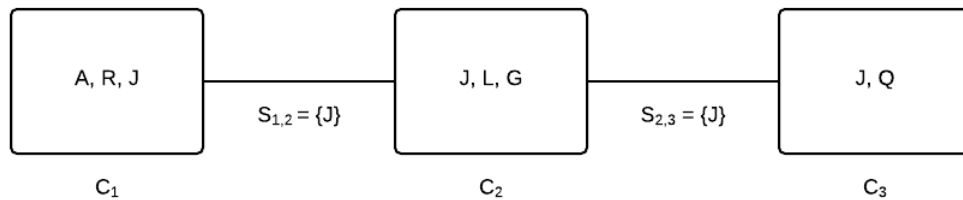
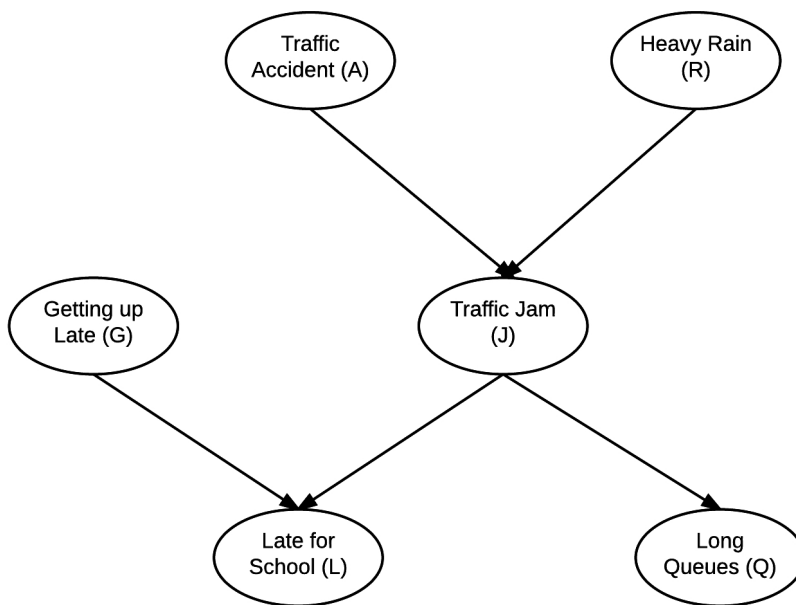
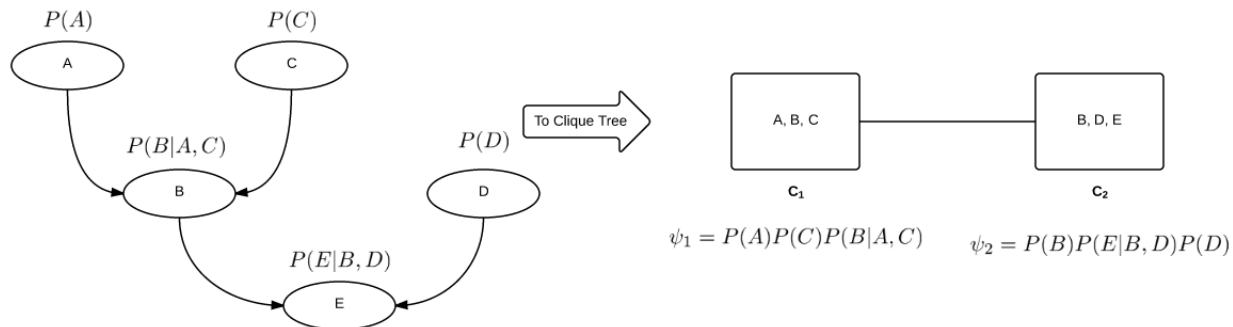
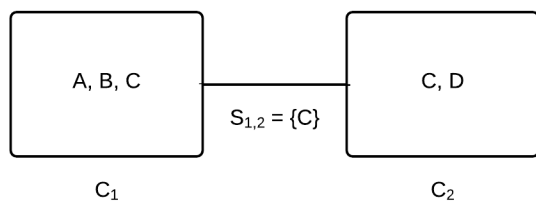

Fig 3.2 (e)



Fig 3.2 (f)





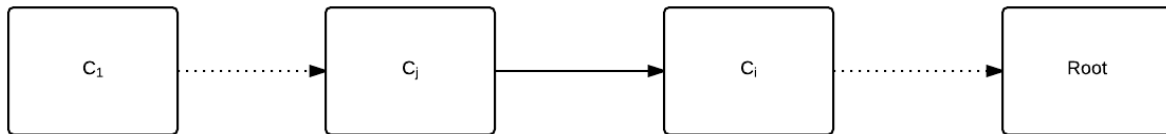
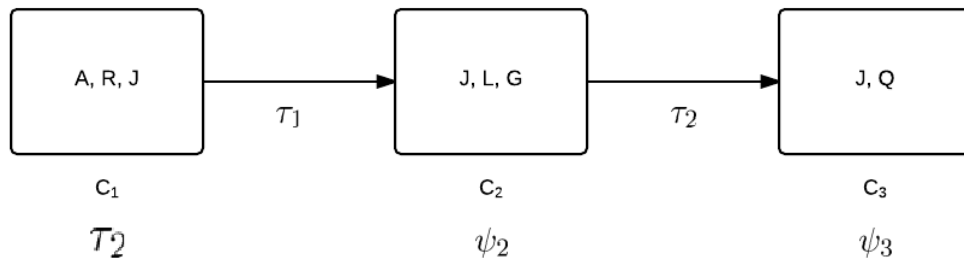
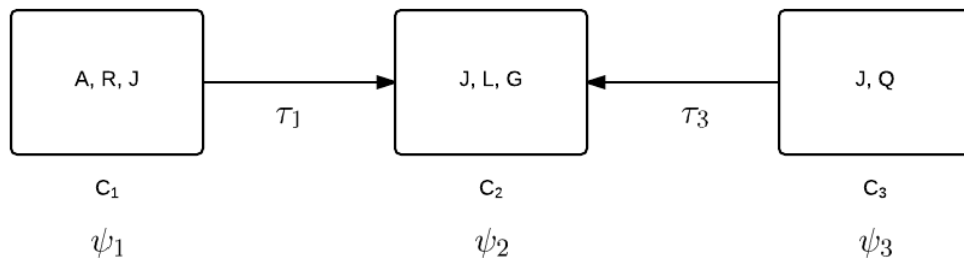

Cluster {E, F, G} is considered as ROOT

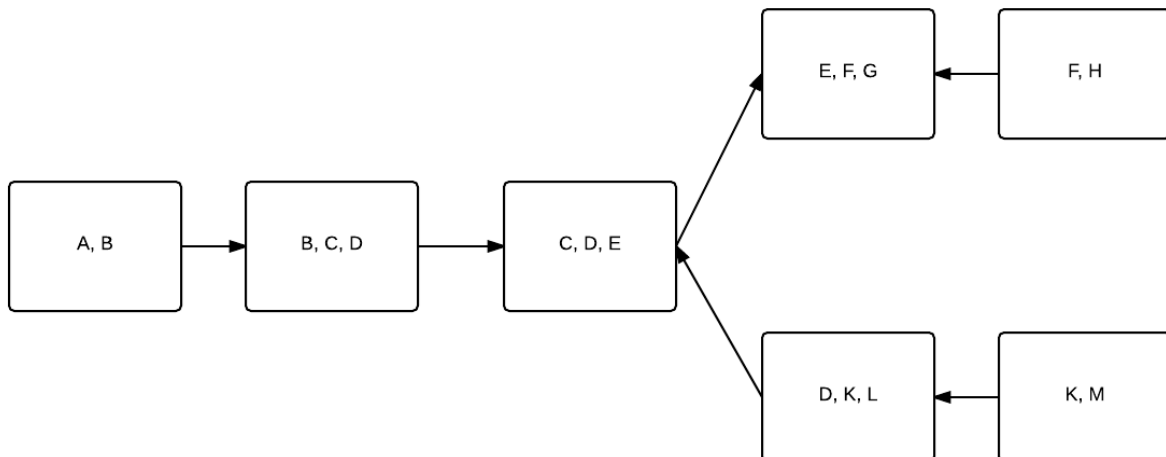

Messages are now transmitted from the root node.

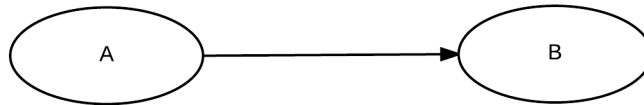
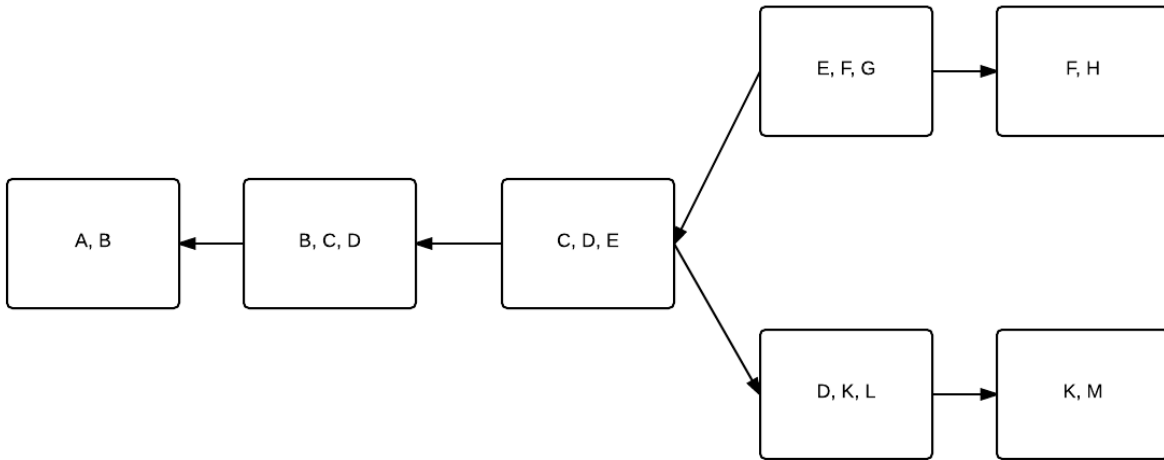

a_0	0.1
a_1	0.9

	a_0	a_1
b_0	0.2	0.56
b_1	0.8	0.44

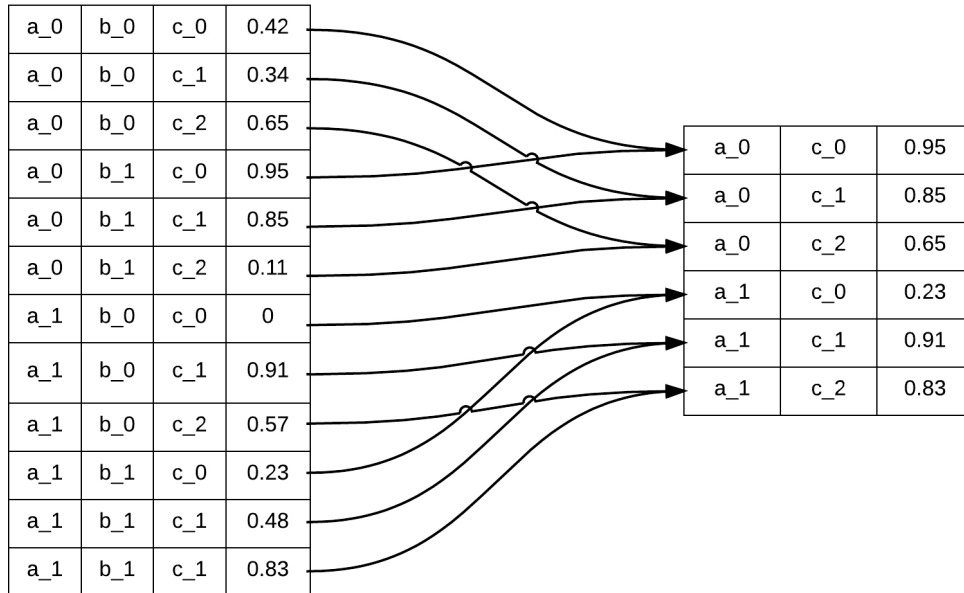

Chapter 4: Approximate Inference

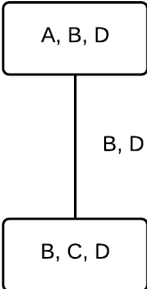
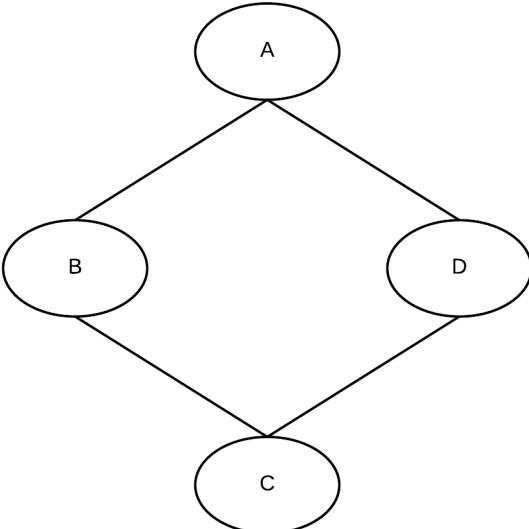

Fig 4.2(a)

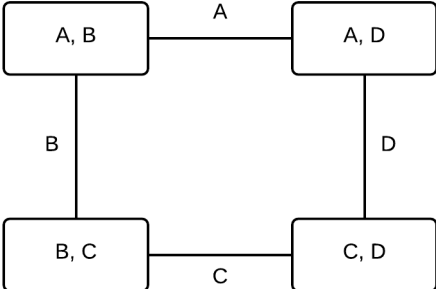
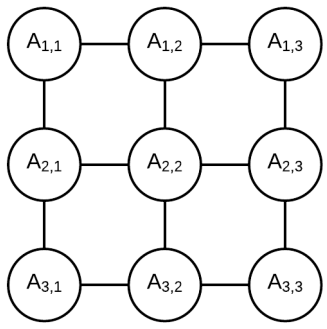
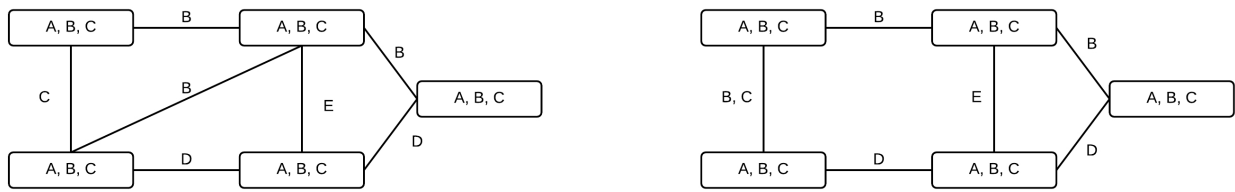
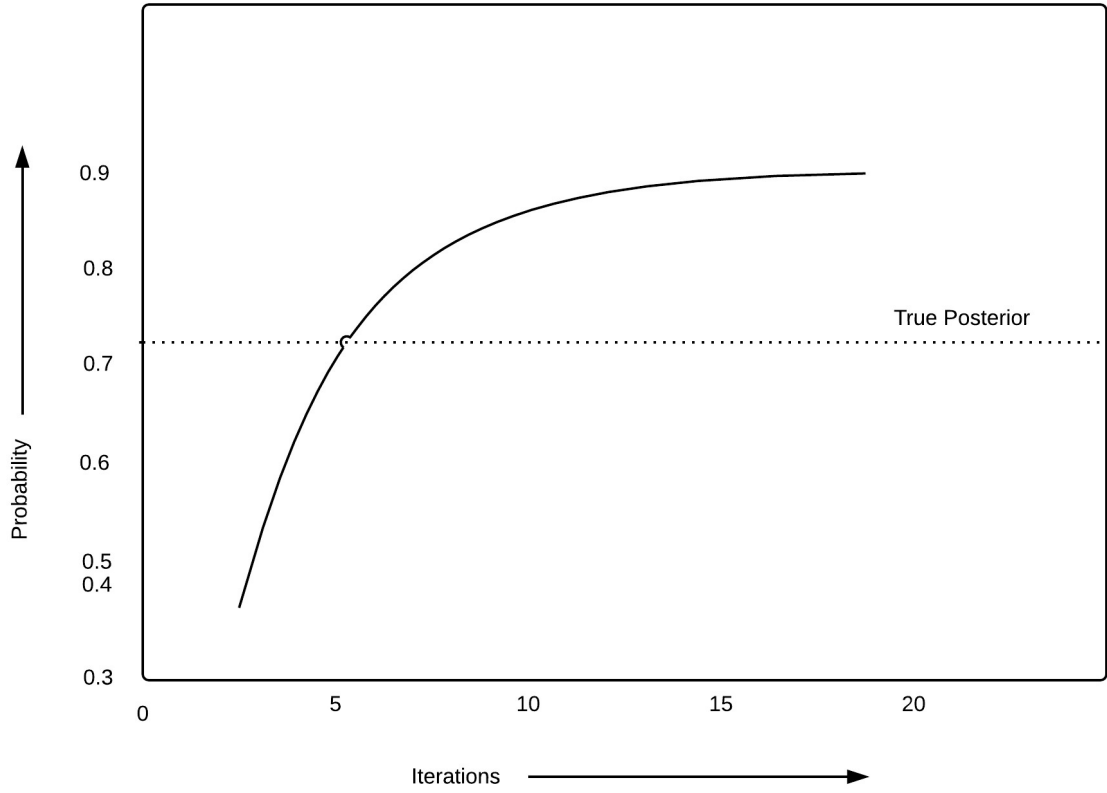
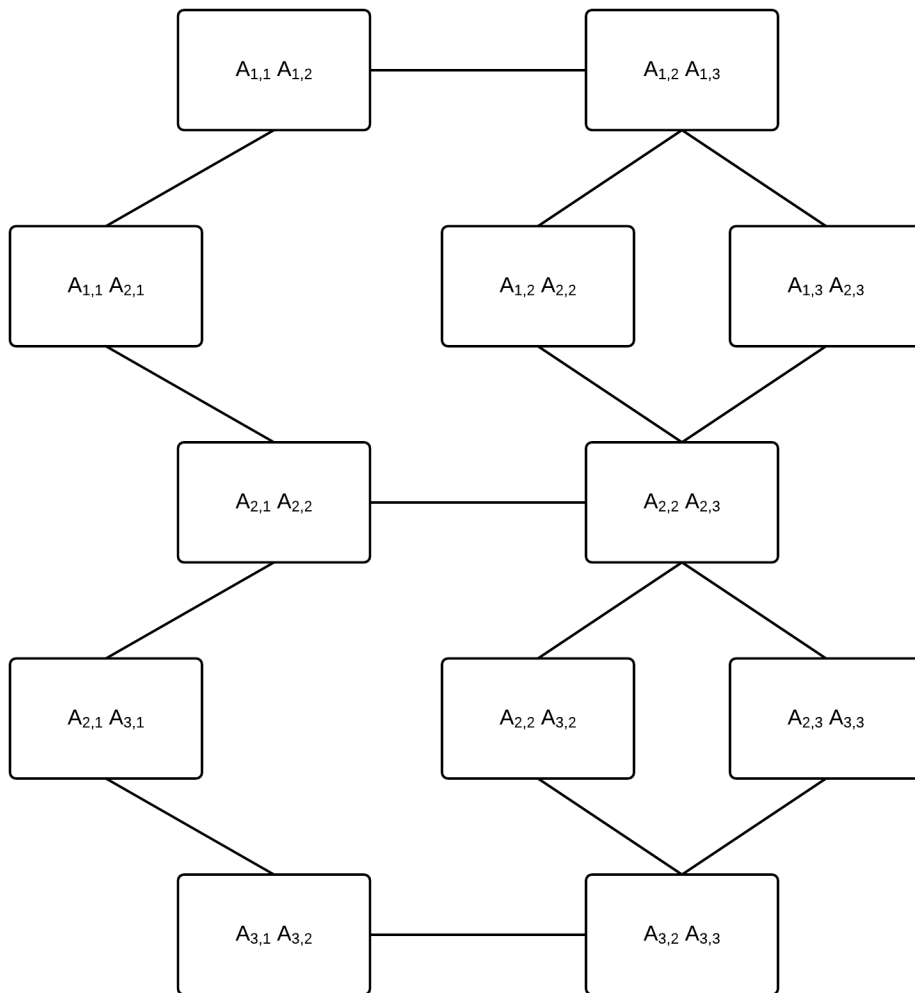
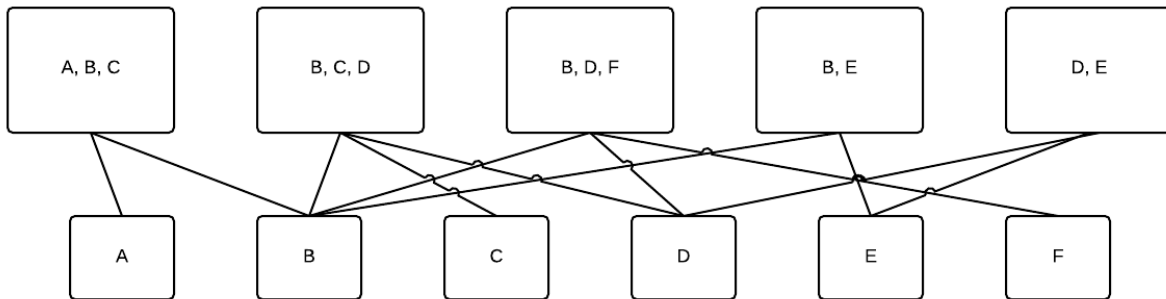
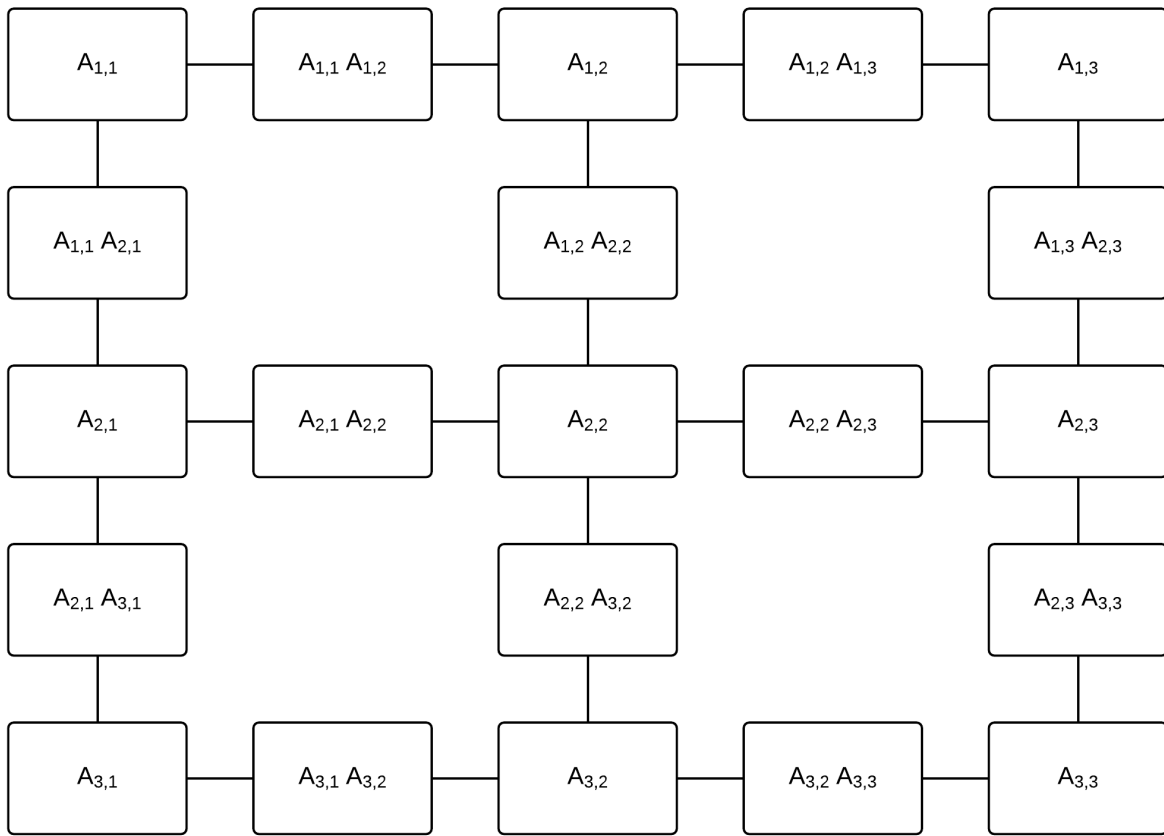
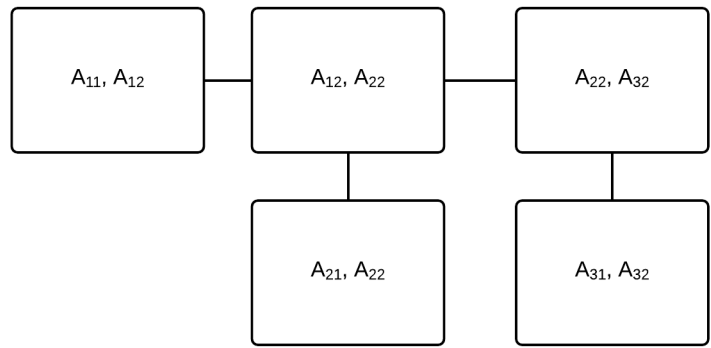
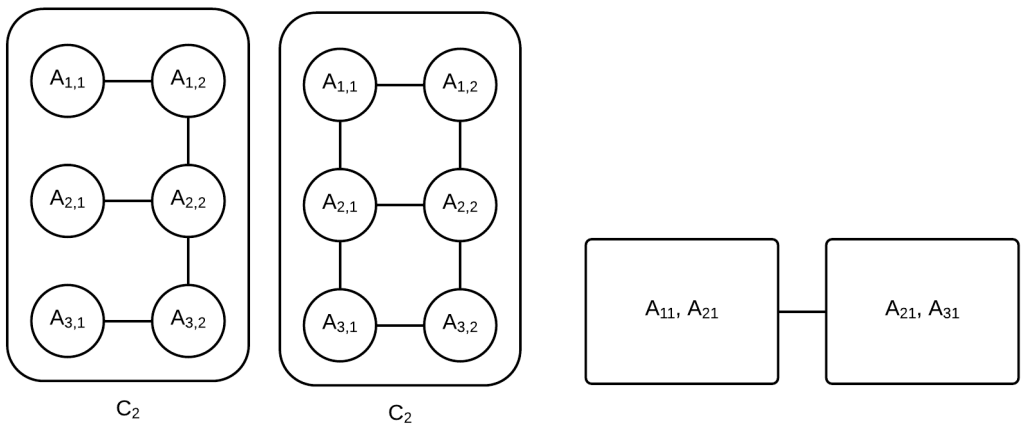
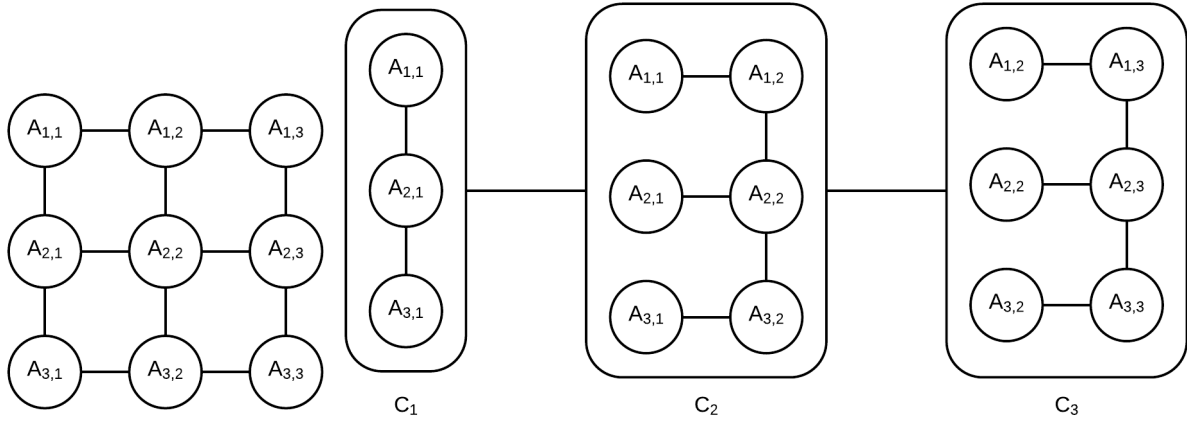

Fig 4.2(b)









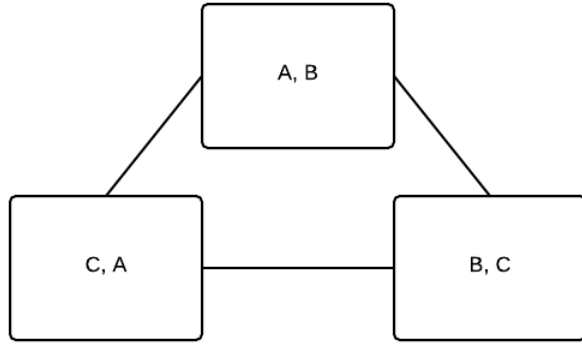
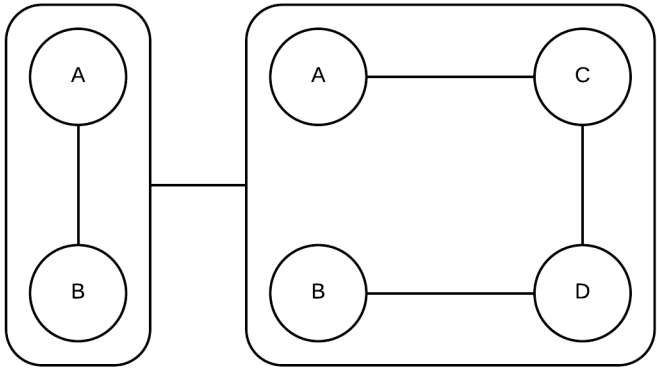
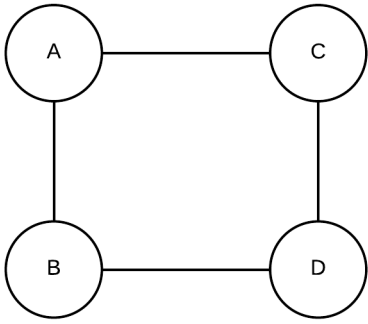

Location	P(L)
Good	0.6
Bad	0.4

Location (L)

Quality (Q)

Quality	P(Q)
Good	0.3
Normal	0.5
Bad	0.2

Cost (C)

No. of People (N)

Location	Good			Bad		
	Good	Normal	Bad	Good	Normal	Bad
Cost						
High	0.8	0.6	0.1	0.6	0.6	0.05
Low	0.2	0.4	0.9	0.4	0.4	0.95

Location	Good		Bad	
	High	Low	High	Low
No. of People				
High	0.6	0.8	0.1	0.6
Low	0.4	0.2	0.9	0.4

Location (L)

l^0	l^1
0.6	0.4

Quality (Q)

q^0	q^1	q^2
0.3	0.5	0.2

Cost (C)

c^0	c^1
1	0

Number Of People (N)

	l^0		l^1	
	c^0	c^1	c^0	c^1
n^0	0.6	0.8	0.1	0.6
n^1	0.4	0.2	0.9	0.4

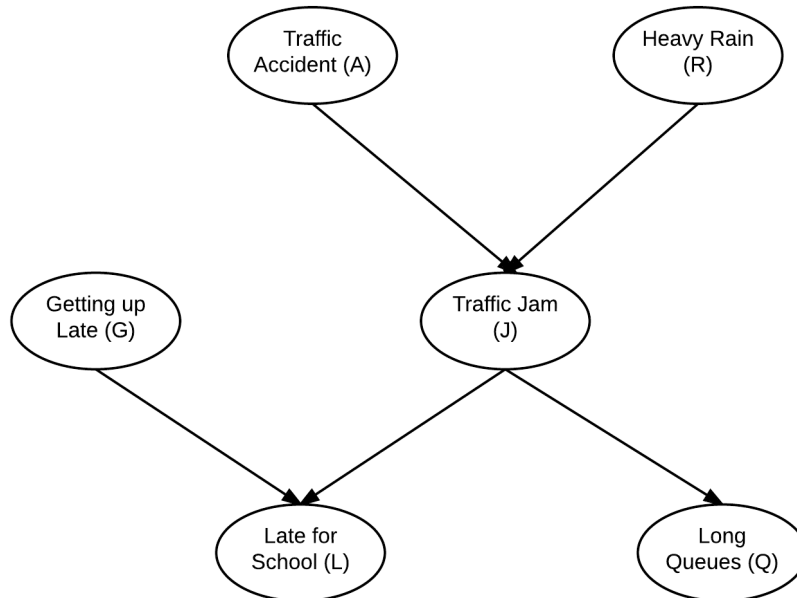
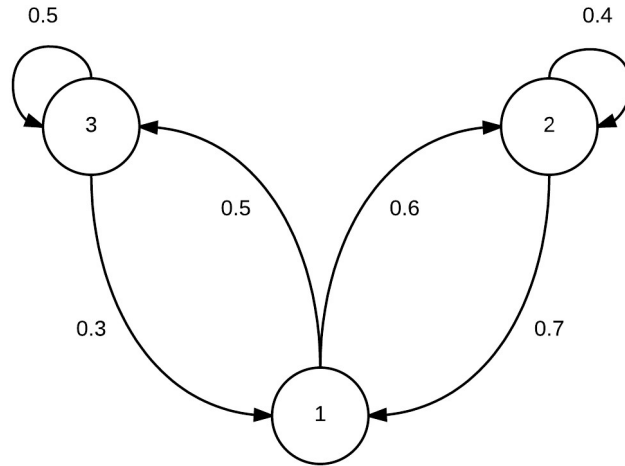
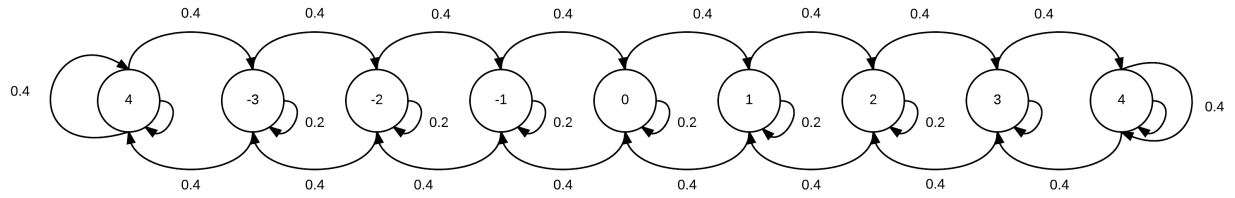

Chapter 5: Model Learning – Parameter Estimation in Bayesian Networks

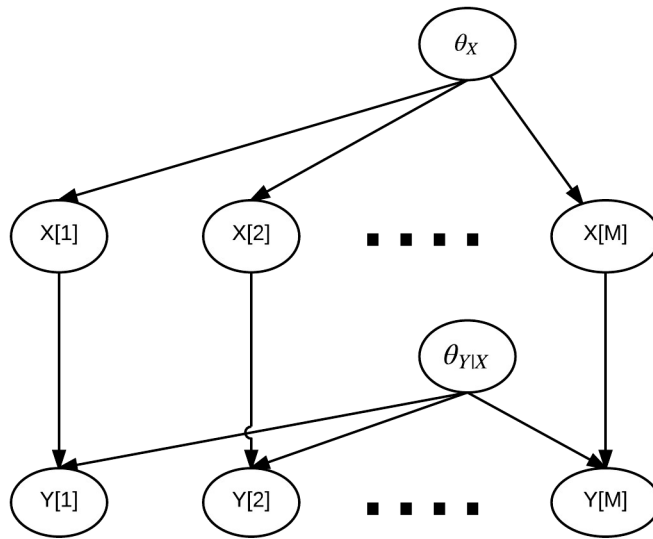
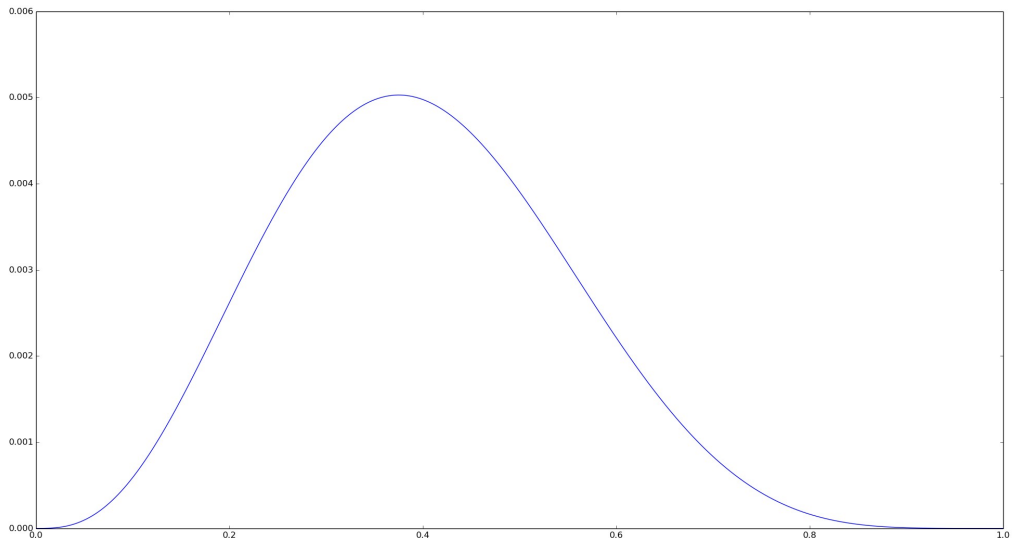

Chapter 6: Model Learning – Parameter Estimation in Markov Networks

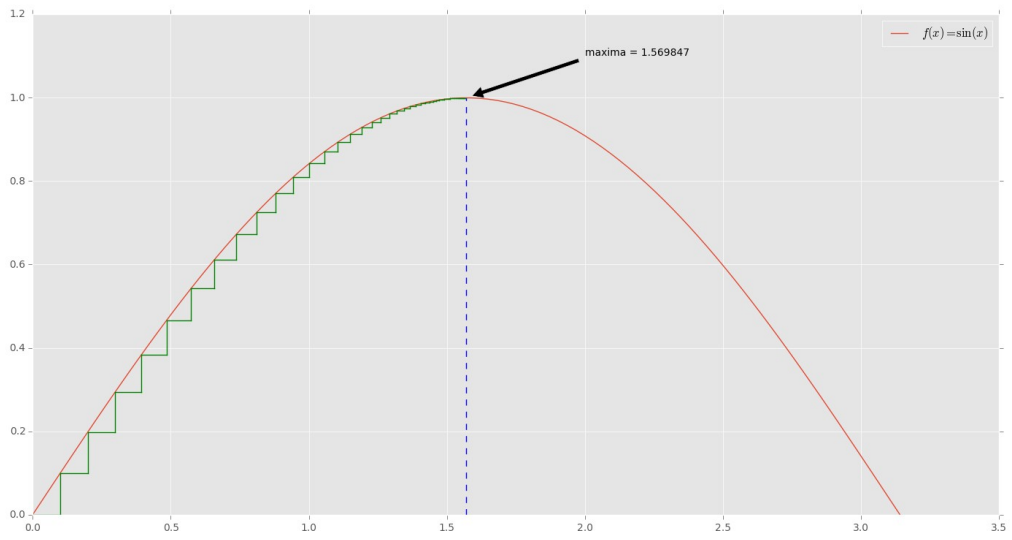
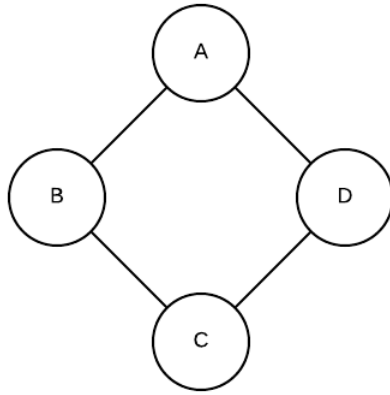

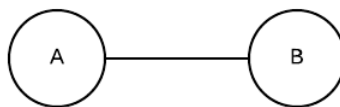
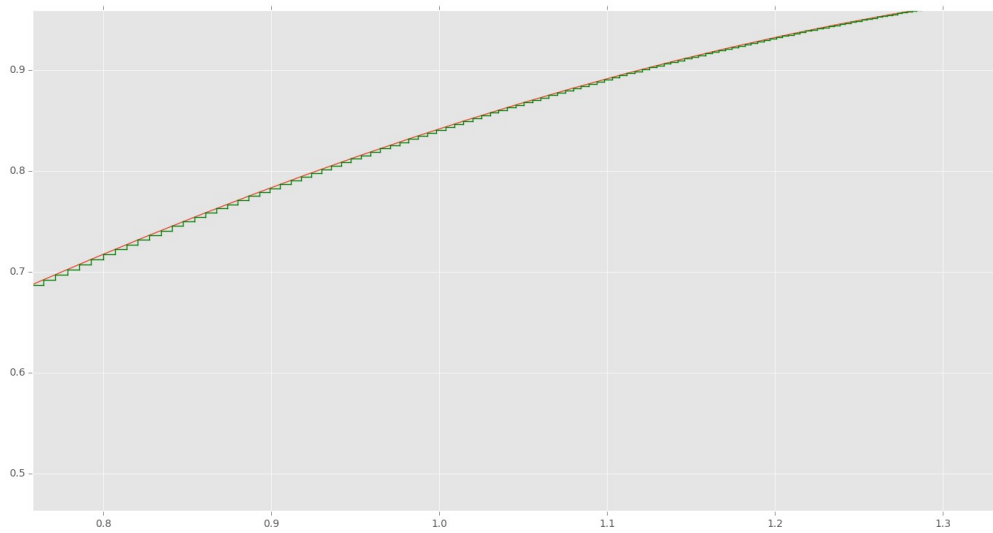
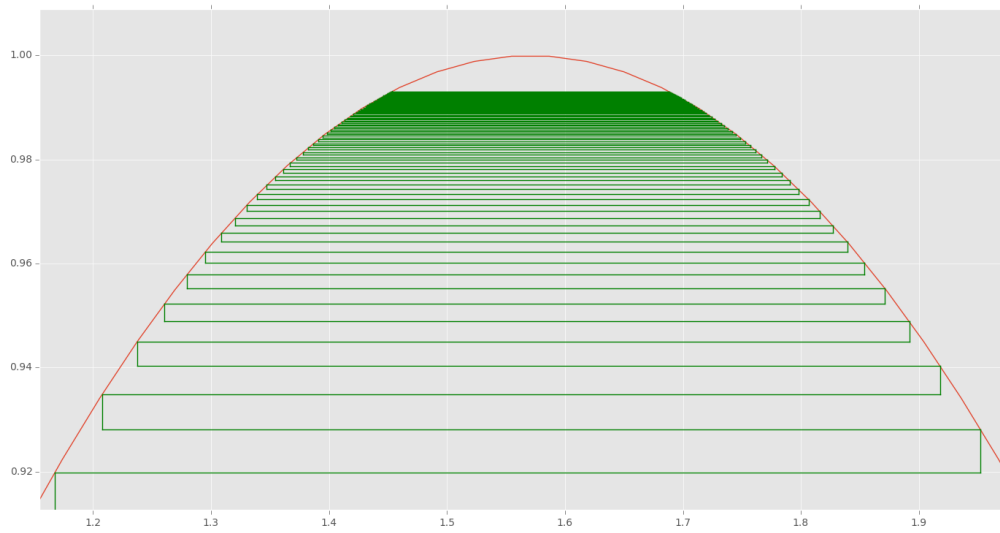

Chapter 7: Specialized Models

